

KAGUYA (SELENE)
Product Format Description

- Lunar Imager/Spectrometer
(LISM (TC/MI/SP)) /
SPICE Kernel-

Version 1.3

February 16, 2010

Change Log

Ver.	Date	Change	Remarks
1.0	09/11/1	The first edition	
1.1	09/11/6	(Revision only in Japanese version (no change in English version))	
1.2	09/11/19	<Appendix-2>p.6(Table 2.1-2) "Strip Division Number" of the Catalog Information File was deleted.	
1.3	10/2/16	<Appendix-1>p.App3-1 Appendix3 "Details of SP Ancillary Information" addition.	

Index

1. Introduction.....	1
1.1 Purpose.....	1
1.2 The composition of this format description	1
2. LISM Products	2

Appendix-1 : LISM RGC Product Format Description

Appendix-2 : LISM DTM / Ortho Product Format Description

Appendix-3 : SPICE Kernel Format Description

1. Introduction

1.1 Purpose

This document describes the format^{*2} used for the catalog and product files for the Lunar Imager/Spectrometer^{*1}(LISM) that was board KAGUYA (SELENE), the format used for the SPICE kernel^{*3}. These files provided by Japan Aerospace Exploration Agency (JAXA).

In addition, the following three high-performance optical instruments (TC, MI, SP) are on LISM.

- Terrain Camera (TC)
- Multi band Imager (MI)
- Spectral Profiler (SP)

*1 : Refer to the following “Project Homepage of KAGUYA” and “Image Gallery of KAGUYA” used for the LISM mission.

- ✓ Project Homepage for KAGUYA
http://www.kaguya.jaxa.jp/en/equipment/tc_e.htm
- ✓ Image Gallery for KAGUYA
TC:
http://wms.selene.darts.isas.jaxa.jp/selene_viewer/en/observation_mission/tc/
MI:
http://wms.selene.darts.isas.jaxa.jp/selene_viewer/en/observation_mission/mi/
SP:
http://wms.selene.darts.isas.jaxa.jp/selene_viewer/en/observation_mission/sp/

*2 : The data format used for SELENE is based on the PDS (Planetary Data System) by NASA. However, the data format is not fully compliant with the PDS format.

*3 : SPICE kernel refers to data which store satellite auxiliary information (time, location, attitude and observation range etc).

1.2 The composition of this format description

Table 1-1 shows the composition of this format description.

Table 1-1 the composition of this format description

No.	INDEX	Title	Description content
1	This Document Chaptar 2	Table 2-1 LALT Products List	The name of the product, the object form, and the composition of the product are described as a product list illustrated by this description.
		Table 2-1 Product Description	Concerning each product shown in the No1 product list, the content included in data and the description of the observation method are illustrated.
		Table 2-3 LISM/SPICE Product Reference of Format Description	The reference of format description of each product is described. The format descriptions of each product are described in the description of Appendix 1, 2, 3.
3	Appendix-1 : LISM RGC Product Format Description		
4	Appendix-2 : LISM DTM / Ortho Product Format Description		
5	Appendix-3 : SPICE Kernel Format Description		

2. LISM Products

The list of LISM/SPICE products, which this document describes, is shown in Table 2-1. The description for each product is shown in Table 2-2.

In addition, the reference of format description of each product is shown in Table 2-4.

Table 2-1 LISM/SPICE Products Lists

Level	Product Name	Product ID	Data Type	Product Format*1	
LISM	Standard	TC_Morning_MAP	TC_Morning_MAP	MAP	A
		TC_Evening_MAP	TC_Evening_MAP	MAP	A
		DTM_TCOrtho	DTM_TCOrtho	IMAGE	D
		MI-VIS_Level2B2	MI-VIS_Level2B2	IMAGE	D
		MI-NIR_Level2B2	MI-NIR_Level2B2	IMAGE	D
		MI-VIS_Level2C2	MI-VIS_Level2C2	IMAGE	D
		MI-NIR_Level2C2	MI-NIR_Level2C2	IMAGE	D
		SP_Level2B1	SP_Level2B1	TBD	A
		SP_Level2B2	SP_Level2B2	TBD	A
		SP_Level2C	SP_Level2C	TBD	A
	SP_Level2D	SP_Level2D	TBD	A	
	Higher Level	TCOrtho_MAP	TCOrtho_MAP	MAP	A
		DTM_MAP	DTM_MAP	MAP	
		MI_MAP	MI_MAP	MAP	A
		DTM_TCOrtho_S	DTM_TCOrtho_S	IMAGE	A
		TCOrtho_MAP_S	TCOrtho_MAP_S	MAP	A
		DTM_MAP_S	DTM_MAP_S	MAP	A
		TCOrtho_MSC	TCOrtho_MSC	IMAGE	A
		DTM_MSC	DTM_MSC	IMAGE	A
Others		Others	Depends on the products		
SPICE	Standard	Spacecraft trajectory	SPK	SPK	D
		Orientation of spacecraft	CK	CK	D
		Spacecraft clock coefficients	SCLK	SCLK	D
	Higher Level	Long period spacecraft clock coefficients	LONG_SCLK	SCLK	D
		RISE Spacecraft trajectory	RISE_SPK	SPK	D

□ :Map product

*1 Product Format : A - Attached, D - Detached

Table 2-2 (1/2) LISM/SPICE Product Description

	Product Name	Product ID	Product Descriptions
LISM	TC_Morning_MAP	TC_Morning_MAP	TC map-projected product mosaicking appropriate TC_s/w_Level2A data taken in solar azimuth condition of east. Each pixel has reflectance value for (incidence, emission, phase angles) of (30°, 0°, 30°). Though the source data of this product are registered to L2DB in Simple Cylindrical, users can choose a map projection type from several ones using L2DB's function.
	TC_Evening_MAP	TC_Evening_MAP	TC map-projected product mosaicking appropriate TC_s/w_Level2A data taken in solar azimuth condition of west. Each pixel has reflectance value for (incidence, emission, phase angles) of (30°, 0°, 30°). Though the source data of this product are registered to L2DB in Simple Cylindrical, users can choose a map projection type from several ones using L2DB's function.
	DTM_TCOrtho	DTM_TCOrtho	This product contains scene data files of Digital Terrain Model (DTM), TC ortho, and qualification flag, created from TC_w_Level2A data: Map projection type of DTM and TC ortho is Simple Cylindrical for latitude of < 60° and Polar Stereo for latitude of > 60°. Each pixel of TC ortho has radiance value.
	MI-VIS_Level2B2	MI-VIS_Level2B2	MI-VIS 5 band images in nominal observation mode. After radiometric correction, conversion to radiance, rubber seating of non-base images to the base images, scene cutting as same observation area and cube generation. Data values are shown in radiance.
	MI-NIR_Level2B2	MI-NIR_Level2B2	MI-NIR 4 band images in nominal observation mode. After radiometric correction, conversion to radiance, rubber seating of non-base images to the base images, scene cutting as same observation area and cube generation. Data values are shown in radiance.
	MI-VIS_Level2C2	MI-VIS_Level2C2	MI-VIS 5 band images in nominal observation mode. After photometric correction, conversion to reflectance and attachment of systematic geometric correction data (latitude and longitude derived by geometric correction). Data values are shown in radiance.
	MI-NIR_Level2C2	MI-NIR_Level2C2	MI-NIR 4 band images in nominal observation mode. After photometric correction, conversion to reflectance and attachment of systematic geometric correction data (latitude and longitude derived by geometric correction). Data values are shown in radiance.
	SP_Level2B1	SP_Level2B1	A SP_Level2B1 product is made of multiple SP_Level 2A products in the same revolution. Radiometric calibration and conversion to diffuse spectral reflectance are also applied.
	SP_Level2B2	SP_Level2B2	A SP_Level2B2 product is extracted from a SP_Level2B1 product based on a TC/MI level 2A product acquired at the same time as SP. A browse image of TC/MI level 2A product used in the extraction process is also attached to this product.
	SP_Level2C	SP_Level2C	A SP_Level2C product is generated from a SP_Level2B2 product by applying spatial correlation analysis with the attached TC/MI image to determine the location of SP observation point in the image as well as photometric correction and reflectance conversion algorithms.

Table 2-3 (1/2) LISM/SPICE Product Description

	Product Name	Product ID	Product Descriptions
LISM	SP_Level2D	SP_Level2D	A SP_Level2D product is generated from SP_Level2C product by applying various spectral data analysis algorithms including spectral unmixing based on Modified Gaussian Model(MGM).
	TCOrtho_MAP	TCOrtho_MAP	Map-projected product mosaicking appropriate TC ortho data in plural DTM TCOrtho products: Though the source data of this product are registered to L2DB in Simple Cylindrical, users can choose a map projection type from several ones using L2DB's function. Each pixel of TC ortho has radiance value.
	DTM_MAP	DTM_MAP	Map-projected product mosaicking appropriate Digital Terrain Model (DTM) data in plural DTM TCOrtho products: Though the source data of this product are registered to L2DB in Simple Cylindrical, users can choose a map projection type from several ones using L2DB's function. Each pixel of TC ortho has radiance value.
	MI_MAP	MI_MAP	Mosaic data after 9 band cube generation and map projection (simple cylindrical). For mosaicing image matching are applied to overlapping area of the original images.
	DTM_TCOrtho_S	DTM_TCOrtho_S	Especially created DTM_TCOrtho product by LISM science members for their personal studies: This product contains scene data files of Digital Terrain Model (DTM), TC ortho, and qualification flag, created from TC_w_Level2A data. Map projection type is Simple Cylindrical or Polar Stereo.
	TCOrtho_MAP_S	TCOrtho_MAP_S	Especially created TCOrtho_MAP product by LISM science members for their personal studies: Though the source data of this product are registered to L2DB in Simple Cylindrical, users can choose a map projection type from several ones using L2DB's function.
	DTM_MAP_S	DTM_MAP_S	Especially created DTM_MAP product by LISM science members for their personal studies. Though the source data of this product are registered to L2DB in a projection type of Simple Cylindrical, users can choose a map projection type from several ones using L2DB's function.
	TCOrtho_MSC	TCOrtho_MSC	Especially created TC ortho mosaicked data from DTM/TC Ortho products by LISM science members for their personal studies: The source DTM/Ortho data, resolution, coefficients for radiometric calibration and geometric correction and so on of this product may be different from those of TCOrtho_MAP(S) product.
	DTM_MSC	DTM_MSC	Especially created DTM mosaicked data from DTM/TC Ortho products by LISM science members for their personal studies: The source DTM/Ortho data, resolution, coefficients for radiometric calibration and geometric correction and so on of this product may be different from those of DTM_MAP(S) product.
	Others	Others	Especially created product using particular calibration/correction parameters or created by LISM science members for their personal studies. Each product corresponding to the Product ID which is shown below. TC_Morning_MAP,TC_Evening_MAP,DTM_TCOrtho,MI-VIS_Level2B2,MI-NIR_Level2B2,MI-VIS_Level2C2,MI-VIS_Level2C3,MI-VIS_Level2C4,MI-NIR_Level2C2,MI-NIR_Level2C3,MI-NIR_Level2C4,SP_Level2B1,SP_Level2B2,SP_Level2C,SP_Level2D,MI_MAP
SPICE	Spacecraft trajectory	SPK	SPICE kernel containing satellite ephemerides
	Orientation of spacecraft	CK	SPICE kernel containing orientation of satellite relative to a specified reference frame
	Spacecraft clock coefficients	SCLK	SPICE kernel containing spacecraft Clock Coefficients - Used for SCLK <-> ET time conversions
	Long period spacecraft clock coefficients	LONG_SCLK	SPICE kernel containing spacecraft Clock Coefficients, converted from original SCLK for long time coverage. - Used for SCLK <-> ET time conversions
	RISE Spacecraft trajectory	RISE_SPK	SPICE kernel containing ephemeris of Main Orbiter using the estimated lunar gravity model

Map product

Table 2-4 (1/4) LISM/SPICE Product Format Description Reference

Product Name		Product ID	Reference	
LISM	TC_Morning_MAP TC_Evening_MAP	TC_Morning_MAP TC_Evening_MAP	Composition of the Data Set	Page.2 Section 2.1 Page.3 Figure 2.1-1
			Rules used for File naming	Page.4 List 2.1-1
			Catalog Information File	Page.5 Section 2.1.1 Page.6 List 2.1-2 --4
			Thumbnail File	Page.7 Section 2.1.2 List 2.1-5
			PDS Product File	Page.8 Section 2.1.3 Figure 2.1-2 Page.9 Figure 2.1-3 Page.10 Section 2.1.3 (1) Page.11,12 List 2.1-6 Page.13 Section 2.1.3 (2) List 2.1-7 Page.14 Section 2.1.3 (3) List 2.1-8
				Low Resolution Data File
	MI-VIS_Level2B2 MI-NIR_Level2B2	MI-VIS_Level2B2 MI-NIR_Level2B2	Composition of the Data Set	Page.16,17 Section 2.2 Page.17 List 2.2-1 Page.18 Figure 2.2-1
			Rules used for File naming	Page.19 List 2.2-2
			Catalog Information File	Page.21 Section 2.2.1 List2.2-4 Page.22 List 2.2-5,6
			Thumbnail File	Page.24 Section 2.2.2 List 2.2-10
			PDS Label	Page.25 Section 2.2.3 Page.26,27 List 2.2-11
			PDS Product File	Page.28 Section 2.2.4 Figure 2.2-3 Page.29 Figure 2.2-4 Page.30 Section 2.2.4 (1) Page.31,32 List 2.2-12 Page.38 Section 2.2.4 (3) List 2.2-16
	MI-VIS_Level2C2 MI-NIR_Level2C2	MI-VIS_Level2C2 MI-NIR_Level2C2	Composition of the Data Set	Page.16,17 Section 2.2 Page.17 List 2.2-1 Page.18 Figure 2.2-1
			Rules used for File naming	Page.19 List 2.2-2
			Catalog Information File	Page.21 Section 2.2.1 List2.2-4 Page.22 List 2.2-5,6
Thumbnail File			Page.24 Section 2.2.2 List 2.2-10	
PDS Label			Page.25 Section 2.2.3 Page.26,27 List 2.2-11	
PDS Product File			Page.28 Section 2.2.4 Figure 2.2-3 Page.29 Figure 2.2-4 Page.30 Section 2.2.4 (1) Page.33,34 List 2.2-13 Page.37 Section 2.2.4 (2) List 2.2-15 Page.38 Section 2.2.4 (3) List 2.2-16	

Appendix-1
LISM RGC
Product
Format
Description

 :Map product

Table 2-3 (2/4) LISM/SPICE Product Format Description Reference

		Product Name	Product ID	Reference	
LISM	MI_MAP	MI_MAP	MI_MAP	Composition of the Data Set	Page.16,17 Section 2.2 Page.17 List 2.2-1 Page.18 Figure 2.2-2
				Rules used for File naming	Page.20 List 2.2-3
				Catalog Information File	Page.21 Section 2.2.1 Page.22 List 2.2-7 Page.23 List 2.2-8,9
				Thumbnail File	Page.24 Section 2.2.2 List 2.2-10
				PDS Product File	Page.28 Section 2.2.4 Figure 2.2-3 Page.29 Figure 2.2-4 Page.30 Section 2.2.4 (1) Page.35,36 List 2.2-14 Page.37 Section 2.2.4 (2) List 2.2-15 Page.38 Section 2.2.4 (3) List 2.2-16
				Low Resolution Data File	Page.39 Section 2.2.5 List 2.2-17
	SP_Level2B1	SP_Level2B1	SP_Level2B1	Composition of the Data Set	Page.40 Section 2.3 Page.41 Figure 2.3-1
				Rules used for File naming	Page.42 List 2.3-1
				Catalog Information File	Page.44 Section 2.3.1 Page.45 List 2.3-3 Page.46 List 2.3-4
				PDS Product File	Page.48 Section 2.3.3 Figure 2.3-3 Page.49 Figure 2.3-4 Page.50 Section 2.3.3 (1) Page.51~55 List 2.3-6 Page.56 Section 2.3.3 (2) Page.57~60 List 2.3-7 Page.61 Section 2.3.3 (3) List 2.3-8
	SP_Level2B2 SP_Level2C SP_Level2D	SP_Level2B2 SP_Level2C SP_Level2D	SP_Level2B2 SP_Level2C SP_Level2D	Composition of the Data Set	Page.40 Section 2.3 Page.41 Figure 2.3-2
				Rules used for File naming	Page.43 List 2.3-2
				Catalog Information File	Page.44 Section 2.3.1 Page.45 List 2.3-3 Page.46 List 2.3-4
				Thumbnail File	Page.47 Section 2.3.2 List 2.3-5 Appendix 1
				PDS Product File	Page.48 Section 2.3.3 Figure 2.3-3 Page.49 Figure 2.3-4 Page.50 Section 2.3.3 (1) Page.51~55 List 2.3-6 Page.56 Section 2.3.3 (2) Page.57~60 List 2.3-7 Page.61 Section 2.3.3 (3) List 2.3-8
Others	Others	Others	Original Resolution JPEG Image File	Page.62 Section 2.3.4 List 2.3-9	
				*1	

Map product

*1 : "Other" is the flowing products

TC_Morning_MAP, TC_Evening_MAP, DTM_TCOrtho, MI-VIS_Level2B2, MI-NIR_Level2B2, MI-VIS_Level2C2, MI-VIS_Level2C3, MI-VIS_Level2C4, MI-NIR_Level2C2, MI-NIR_Level2C3, MI-NIR_Level2C4, SP_Level2B1, SP_Level2B2, SP_Level2C, SP_Level2D, MI_MAP

Table 2-3 (3/4) LISM/SPICE Product Format Description Reference

	Product Name	Product ID	Reference		
LISM	DTM_TCOrtho DTM_TCOrtho_S	DTM_TCOrtho	Composition of the Data Set	Page.2 Section 2.1 Page.2 Fig 2.1-1 Page.3 Fig 2.1-2	
			Rules used for File naming	Page.4 Table 2.1-1	
			Catalog Information File	Page.5 Section 2.1.1 page.5,6 Table 2.1-2 Page.7 Table 2.1-3,4	
		DTM_TCOrtho_S	Thumbnail File	Page.8 Section 2.1.2 Table 2.1-5	
			PDSLabel (L2DB)	Page.9 Section 2.1.3 Fig 2.1-3 Table 2.1-6	
			tar Object File	Page.10 Section 2.1.4 Fig 2.1-4 Fig 2.1-5 Page.10 Section 2.1.4 (1) Page.11~14 Table 2.1-7 Page.15,16 Table 2.1-8 Page.17~20 Table 2.1.9 Page.21 Section 2.1.4 (2) Table 2.1-10	
	DTM_MAP DTM_MAP_S	DTM_MAP	Composition of the Data Set	Page.22 Section 2.2 Fig 2.2-1 Fig 2.2-2	
			Rules used for File naming	Page.23 Table 2.2-1	
		DTM_MAP_S	Catalog Information File	Page.24 Section 2.2.1 Page.24,25 Table 2.2-2 Page.25 Table 2.2-3 Table 2.2-4	
			Thumbnail File	Page.26 Section 2.2.2 Table 2.2-5	
	DTM_MSC	DTM_MSC	PDS Product File	Page.27 Section 2.2.3 Fig 2.2-3 Fig 2.2-4 Page.27 Section 2.2.3 (1) Page.28~30 Table 2.2-6 Page.31 Section 2.2.3 (2) Table 2.2-7	
			Low Resolution Data File	Page.31 Section 2.2.4 Fig 2.2-5	
	TCOrtho_MAP TCOrtho_MAP_S	TCOrtho_MAP	Composition of the Data Set	Page.32 Section 2.3 Fig 2.3-1 Fig 2.3-2	
			Rules used for File naming	Page.33 Table 2.3-1	
	TCOrtho_MAP_S	TCOrtho_MAP_S	Catalog Information File	Page.34 Section 2.3.1 Page.34,35 Table 2.3-2 Page.35 Table 2.3-3 Table 2.3-4	
			Thumbnail File	Page.36 Section 2.3.2 Table 2.3-5	
		TCOrtho_MSC	TCOrtho_MSC	PDS Product File	Page.37 Section 2.3.3 Fig 2.3-3 Fig 2.3-4 Page.37 Section 2.3.3 (1) Page.38~40 Table 2.3-6 Page.41 Section 2.3.3(2) Table 2.3-7
				Low Resolution Data File	Page.41 Section 2.3.4

 :Map product

Table 2-3 (4/4) LISM/SPICE Product Format Description Reference

	Product Name	Product ID	Reference		
SPICE	Spacecraft clock coefficients (Long period spacecraft clock coefficients)	SCLK (LONG_SCLK)	Composition of the Data Set	Appendix-3 SPICE Kernel Format Description	Page.1 Capter 2 Figure 2-1 Table 2-1
	Spacecraft trajectory (RISE Spacecraft trajectory)	SPK (RISE_SPK)	Rules used for File naming		Page.2 Table 2-2,3 Page.3 Table 2-4
			Catalog Information File		Page.4 Section 2.1 Table 2-5
	Orientation of spacecraft	CK	PDS Label		Page.5 Section 2.2 Table 2-6
			SPICE Kernel		Page.6 Section 2.3 Table 2-7

**KAGUYA (SELENE)
Product Format Description
- LISM (TC/MI/SP) /SPICE Kernel-**

Appendix-1

LISM RGC Product Format Description

Version 1.1

February 16, 2010

Contents

1. The general.....	1
1.1 Purpose.....	1
1.1.1 Reference books.....	1
2. RGC data set.....	2
2.1 TC.....	2
2.1.1 TC catalog information file.....	5
2.1.2 TC thumbnail file.....	7
2.1.3 TC PDS product file	8
2.1.4 TC low resolution data file.....	15
2.2 MI.....	16
2.2.1 MI catalog information file.....	21
2.2.2 MI thumbnail file.....	24
2.2.3 MI PDS label	25
2.2.4 MI PDS product file.....	28
2.2.5 MI low resolution data file.....	39
2.3 SP.....	40
2.3.1 SP catalog information file	44
2.3.2 SP thumbnail file	47
2.3.3 SP PDS product file.....	48
2.3.4 SP original resolution JPEG image file.....	62

Appendix1 “Rotation/reverse of the thumbnail image“

Appendix2 “Details of the invalid pixel“

Appendix3 “Details of SP Ancillary Information“

Change Log

Ver.	Date	Change	Remarks
1.0	09/11/1	The first edition	
1.1	10/2/16	P67-68 Appendix3 "Details of SP Ancillary Information" addition	

1. The general

1.1 Purpose

This document describes the formats of the Radiometric calibration and Geometric correction (RGC) Data Set. These files provided by Japan Aerospace Exploration Agency (JAXA).

1.2 Reference books

- (1) Planetary Data System Standards Reference Version 3.5
- (2) Digital compression and coding of continuous-tone still images (ISO/IEC 10918-1)
- (3) 「Documentation of LISM level 2A product file format」(RCX-05007)
- (4) 「Functions for creating LISM SP level 2 product」(RCX-03006)

2. RGC data set

The composition of RGC data set varies by detector, band, process level or geometric correction option. After the following page, the details of each data set are shown.

2.1 TC

RGC data set of TC is broken into the following 9 process levels and geometric correction options.

- L2B0 data
- L2C1 data
- L2C3 data
- L2C4 data
- L3C1 data
- L3C3 data
- L3C4 data
- MAP data
- MSC data

Among above, in L2B0~L3C4 data, first 3 characters show process level and the last fourth character shows geometric correction option. MAP data, being data registered in L2DB as a map product, are created by mosaicking several L3C, MAP and MSC data (mosaic processing). MSC data, being mosaic data but not a map product, are created by mosaicking several L3C, MAP and MSC data.

RGC data set of TC is created by tar-archiving the following files.

- Catalog information file
- PDS product file
- PDS label
- Thumbnail file
- Low resolution file

The PDS product file of MAP data is not gzip-compressed and along with the catalog information file, the thumbnail file, and the low resolution file, those 4 files are tar-archived.

In the Figure 2.1-1, the composition of TC RGC data set of TC MAP data set is shown.

The file nomenclature rule of MAP is described in the List 2.1-1 below.

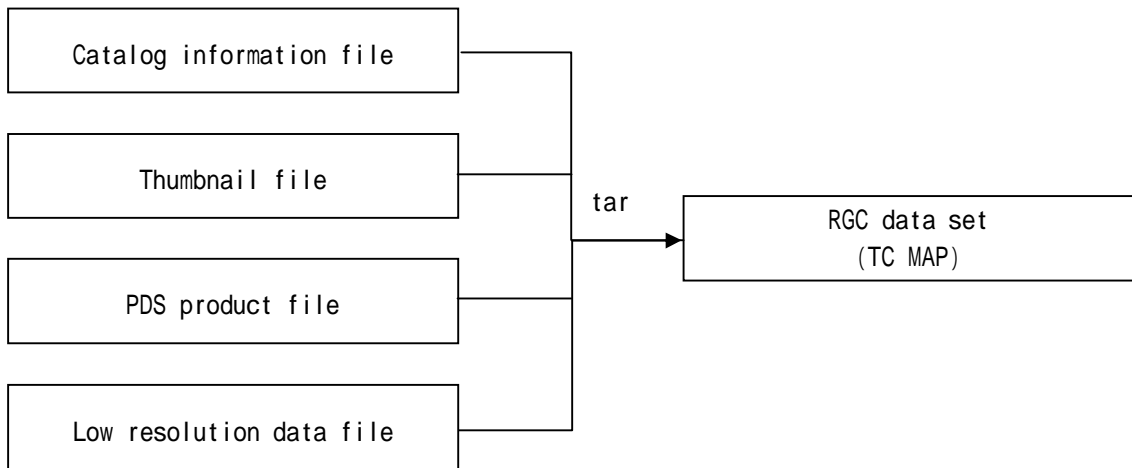

Figure 2.1-1 Composition of TC RGC data set (MAP data set)

List 2.1-1 File nomenclature rule of TC (MAP)

No.	Starting position	Length (byte)	Set value
1	1	2	Sensor type TC:fixation
2	3	1	Underscore _:fixation
3	4	3	Process type MOR:morning MAP EVE:evening MAP
4	7	1	Underscore _:fixation
5	8	2	Registered version in L2DB or individualized data set ID nn:2-digit number(registered version in L2DB) number and alphabet of big or small letters (individualized data set ID)
6	10	1	Underscore _:fixation
7	11	1	Discrimination of north or south hemisphere on north edge in the mosaic area N:North hemisphere S:South hemisphere
8	12	2	Latitude of north edge in the mosaic area (deg) nn:2-digit, only integer part round the first decimal place nn=00~90
9	14	4	Longitude of west edge in the mosaic area (deg) Ennn:E shows east longitude, nnn:3-digit, only integer part, round the first decimal place nnn=000~360
10	18	1	Discrimination of north or south hemisphere on south edge in the mosaic area N:North hemisphere S:South hemisphere
11	19	2	Latitude of south edge in the mosaic area (deg) nn:2-digit, only integer part round the first decimal place nn=00~90
12	21	4	Longitude of east edge in the mosaic area (deg) Ennn:E shows east longitude, nnn:3-digit, only integer part, round the first decimal place nnn=000~360
13	25	2	Map projection SC:Simple cylindrical projection MR:Mercator projection ML:Mollweide projection SN:Sinusoidal projection LM:Lambert conformal conic projection(1standard parallel) OR:Orthographic projection ST:Stereographic projection(including Polar stereo projection)
14	27 (other than divided mosaic)	4	Extension .img:RGC PDS product file(non-gzip compression) .jpg:thumbnail file .ctg:catalog information file .sl2:RGC data set
Total		30:other than non-MAP divided mosaic	

2.1.1 TC catalog information file

Catalog information file is the information file attached to explain the general of RGC PDS product and is used to search for the product from L2DB subsystem.

The details of items in the catalog information file are shown in the list of List 2.1-2~List 2.1-4. In comment information, multiple items described in the list of details of items in the catalog information file are recorded in the comma-delimited "keyword=value" form.

And on each item of the catalog information, value is basis of zero suppression in the absence of mentioning of particular reference.

List 2.1-2 Details of items in catalog information file (TC MAP)

Item name	Keyword	Format of set value	Set contents
Data file name	DataFileName	AAAA...AAAA (up to 31-digit)	RGC PDS product name
Data file size	DataFileSize	NNNNNNNNNN (up to 12-digit)	RGC PDS product file size
Data file format	DataFileFormat	AAAA...AAAA (up to 16-digit)	RGC PDS product file format
Thumbnail file name	ThumbnailFileName	AAAA...AAAA (up to 31-digit)	Thumbnail file name
Thumbnail file size	ThumbnailFileSize	NNNNNNNNNN (up to 12-digit)	Thumbnail file size
Thumbnail file format	ThumbnailFileFormat	AAAA (up to 4-digit)	JPEG format
Instrument name	InstrumentName	AAAA...AAAA (up to 16-digit)	LISM
Processing level	ProcessingLevel	AAAA...AAAA (up to 16-digit)	Processing level
Product identification	ProductID	AAAA...AAAA (up to 30-digit)	TC_Morning_MAP TC_Evening_MAP Others
Product version	ProductVersion	AAAA...AAAA (up to 16-digit)	nn : L2DB registered version
Access level	AccessLevel	N	Setting any value among following: 0:prohibition of overwriting 1:access permission given to the only core members in the instrument group 2:access permission given to the members in the instrument group 3:access permission given to the members in both the instrument group and the SELENE mission 4:access permission given to all users (opening to the public)
Upper left latitude of this scene	UpperLeftLatitude	SNN.NNNNNN	[-90, 90]
Upper left longitude of this scene	UpperLeftLongitude	NNN.NNNNNN	[0, 360]
Upper right latitude of this scene	UpperRightLatitude	SNN.NNNNNN	[-90, 90]
Upper right longitude of this scene	UpperRightLongitude	NNN.NNNNNN	[0, 360]
Lower left latitude of this scene	LowerLeftLatitude	SNN.NNNNNN	[-90, 90]
Lower left longitude of this scene	LowerLeftLongitude	NNN.NNNNNN	[0, 360]
Lower right latitude of this scene	LowerRightLatitude	SNN.NNNNNN	[-90, 90]
Lower right longitude of this scene	LowerRightLongitude	NNN.NNNNNN	[0, 360]
Center latitude of this scene	SceneCenterLatitude	SNN.NNNNNN	[-90, 90]
Center longitude of this scene	SceneCenterLongitude	NNN.NNNNNN	[0, 360]
Comment information	CommentInfo	AAAA...AAAA (up to 4000-	Refer to the list 2.1-11
Free keyword	Freekeyword		Refer to the list 2.1-10

List 2.1-3 Details of free keyword items in catalog information file (TC MAP)

Item name	Keyword	Type	Format of set value	Set contents
Number of saturated pixels	SaturatedPixels	Integral value	NNNN...NNN	Number of saturated pixels among invalid pixels
Maximum DN in this scene	SceneMaximumDN	Integral value	NNN...NNN	Image evaluation: maximum value of pixels in this scene
Average DN in this scene	SceneAverageDN	Real value	SNN...N.NNN	Image evaluation: average value of pixels in this scene
Standard deviation DN in this scene	SceneStdevDN	Real value	SNN...N.NNN	Image evaluation: standard deviation value of pixels in this scene
Mode DN in this scene	SceneModeDN	Integral value	NNN...NNN	Image evaluation: scene mode of pixels in this scene
Shadowed area percentage between D5 and D6	ShadowedAreaPercentage	Integral value	NN...N	Shadowed area percentage of pixels

List 2.1-4 Details of comment information in catalog information file (TC MAP)

Item name	Keyword	Format of set value	Set content
Product creation time	ProductCreationTime=%s	AAA(20 characters)	Product creation time
Source L2A data file name	SourceLevel2AFileName=%s*	AAA...AAA	All source L2A data file names used for creating this PDS product. When the number of CommentInfo is over 4000, the value is shortened into "%s...".
Mission phase name	MissionPhaseName=%s*	AAA...AAA	Mission phase name

2.1.2 TC thumbnail file

Thumbnail file is the reduced image of image data object included in RGC data set, and is the JPEG format image.

And on the details of JPEG, refer to the reference book (2).

Depending on the moving direction of the spacecraft and ascending/descending of the orbit, a thumbnail image is rotated/reversed in such a way that upper part of it can be just about north direction and right of it can be just about east direction. Involving (a) pole(s), it is not rotated/reversed. On the details of a thumbnail image's rotation/reverse, refer to Appendix1.

The specifications of thumbnail file are described in the List 2.1-5

List 2.1-5 Specifications of thumbnail file

Number of horizontal pixels	Number of vertical pixels	File size	Format
512 or less	512 or less	100kb or less	8bitJPEG

When the size of image data object is smaller than the aforesaid size; the size of thumbnail file is the same as one of the image data object.

2.1.3 TC PDS product file

RGC PDS product file of TC is the PDS file in attached format, and is composed of PDS label segment (header segment), geometric information object, and image data object. PDS label is recorded in text format, and geometric information object and image data object are recorded in binary format.

The composition of TC RGC PDS product file is shown in the Figure 2.1-2 and the format of TC RGC PDS product file is shown in the Figure 2.1-3.

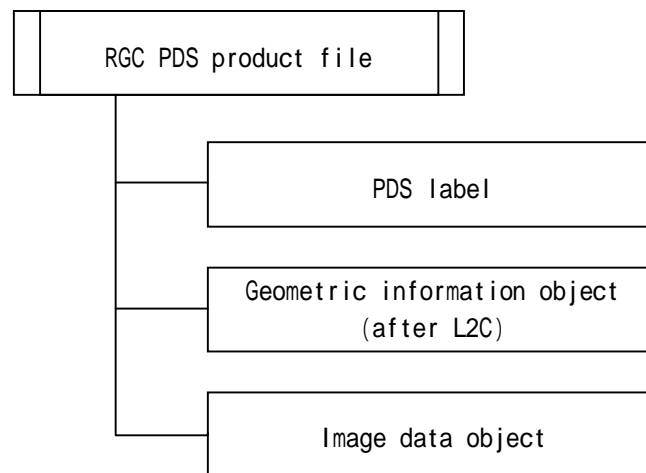

Figure 2.1-2 Composition of TC RGC PDS product file

PDS label	<ul style="list-style-type: none"> • Prerequisite items for PDS header Version identification		
	<ul style="list-style-type: none"> • Area specifying object position Pointer to all objects		
	Product information	<ul style="list-style-type: none"> • File attribute e.g. file name, creating date, update date	
		<ul style="list-style-type: none"> • Product attribute e.g. software name used for creating product, producer identification, source data file name	
		Scene attribute	<ul style="list-style-type: none"> • Common to each instrument e.g. start time of the scene, stop time of the scene, observation mode name
			<ul style="list-style-type: none"> • Variation by each instrument e.g. observation parameters, status
	<ul style="list-style-type: none"> • Description area of geometric data object format (altitude: for MAP) e.g. thinning interval of geometric data, number of data points in vertical and horizontal direction, bit length		
<ul style="list-style-type: none"> • Description area of image data object format e.g. number of vertical and horizontal pixels of the scene, bit length			
<ul style="list-style-type: none"> • Geometric data object(altitude: for MAP) Binary two dimensional array data			
<ul style="list-style-type: none"> • Image data object Binary two dimensional array data			

Figure 2.1-3 Format of TC RGC PDS product file

(1)PDS label

The details of PDS label of TC RGC PDS product file are shown in the list of List 2.1-6.

And on the case that the set value of PDS label is numeric value, if it does not fulfill maximum digit number, it is left-aligned by zero suppression in the absence of mentioning of particular reference.

On the details of the invalid pixel, refer to Appendix2.

List 2.1-6(1/2) Details of PDS label (TC MAP)

Region	Item name	Description format	Item explanation	value		
Prerequisite items for PDS header	PDS version identification	PDS_VERSION_ID = "%s"	PDS version identification	"PDS3"		
	File record type	RECORD_TYPE = "%s"	File record type (prerequisite for L2DB registration)	"UNDEFINED"		
	File name (L2DB regulation)	FILE_NAME = "%s"	File name (prerequisite for L2DB)(uniquely decidable file name, involving extension(.img))	***.img		
	Product identification (PDS practice)	PRODUCT_ID = "%s"	Product identification (uniquely decidable file name, not involving extension)	***(no extension)		
	Data file format identification	DATA_FORMAT = "%s"	Data file format identification (prerequisite for L2DB registration)	"PDS"		
Area specifying object position	Starting position of geometric data (altitude)	^GEOMETRIC_DATA_ALTITUDE = %d <BYTES>	Starting position of geometric data (altitude)(in Byte) This keyword may be omitted.			
	Starting position of image object	^IMAGE = %d <BYTES>	Starting position of image object(in Byte)			
Product information	File attribute	Software name	SOFTWARE_NAME = "%s"	Software name used for creating PDS product	"RGC.TC.MI"	
		Software version	SOFTWARE_VERSION = "%s"	Software version used for creating PDS product	n.n.n	
		Process version identification	PROCESS_VERSION_ID = "%s"	Process version identification (prerequisite for L2DB registration)	"MAP","MSC"	
		Product creation time	PRODUCT_CREATION_TIME = %s	Product creation time(UTC)	YYYY-MM-DDThh:mm:ssZ	
		Program start time	PROGRAM_START_TIME = %s	Program start time (UTC)	YYYY-MM-DDThh:mm:ssZ	
		Producer identification	PRODUCER_ID = "%s"	Data producer identification	"LISM"	
	Product attribute	Product set identification	PRODUCT_SET_ID = "%s"	PDS product set types (prerequisite for L2DB registration) The name in product list should be used. As of data not registered in L2DB, it's be described "Others".	"TC_Morning_MAP", "TC_Evening_MAP", "Others"	
		Product version identification	PRODUCT_VERSION_ID = "%s"	Product version registered for L2DB (prerequisite for L2DB registration)	"00" - "99"	
		Whether to be registered product in L2DB	REGISTERED_PRODUCT = "%s"	It's be set whether it was created as product for registration, regardless of success and failure of registration in L2DB.	"Y" or "N"	
		Source data file name(L2A)	LEVEL2A_FILE_NAME = ("{"%s", "%s"} {"%s"} {"%s"}...)	Source data file names used for creating this PDS product. This keyword may be omitted.	***.img	
		SPICE metakernel file name	SPICE_METAKERNEL_FILE_NAME = ("{"%s", "%s"} {"%s"}...)	SPICE metakernel file names used for creating PDS product. This keyword may be omitted.		
	Scene attribute	Common to each instrument	Mission name	MISSION_NAME = "%s"	Mission name	"SELENE"
			Spacecraft name	SPACECRAFT_NAME = "%s"	Spacecraft name	"SELENE-M"
			Data set identification	DATA_SET_ID = "%s"	Data set identification in which included this scene.	
			Instrument name	INSTRUMENT_NAME = "%s"	Instrument name(full name) (prerequisite for L2DB registration)	"Terrain Camera"
Instrument identification			INSTRUMENT_ID = "%s"	Instrument identification	"TC"	
Observation target name			TARGET_NAME = "%s"	Observation target name of this strip	"MOON"(default)	
Observation mode identification			OBSERVATION_MODE_ID = "%s"	Observation mode identification	"NORMAL":normal "SUPPORT":support "NORMAL&SUPPORT":normal and support image mosaic in TC_MAP/MSC	
Sensor description			SENSOR_DESCRIPTION = "%s"	Sensor description. (e.g.TC:scan mode, TC1/2relative mounting angle, element number of used detector, focal length, F value, IFOV, field of view angle, range of wavelengths, aperture, explanation of swath mode, explanation of compression mode, explanation of exposure mode, Bit number of AD converter)		
Sensor description 2			SENSOR_DESCRIPTION2 = "%s"	Alternative sensor description		
Description area of geometric data (altitude) object format		OBJECT = GEOMETRIC_DATA_ALTITUDE	This keyword may be omitted.			
	Thinnig start pixel position	BINNING_START_PIXEL_POSITION = (%d,%d)	Start pixel position for thinnig in this scene	(1,1)		
	Thinnig interval	BINNING_INTERVAL = %d	Thinnig interval			
	Number of lines	LINES = %d	Number of pixels along the vertical axis of this scene.			
	Number of line's samples	LINE_SAMPLES = %d	Number of pixels along the horizontal axis of this scene.			
	Sample type	SAMPLE_TYPE = "%s"	Sample type	"IEEE_REAL"		
	Sample bits	SAMPLE_BITS = %d	Sample bit length	32		
	Unit	UNIT = "%s"	Unit of sample value	"km"		
	Description area of image data object format		OBJECT = IMAGE			
Number of bands		BANDS = %d	Number of bands	1		
Band storage type		BAND_STORAGE_TYPE = "%s"	Storage type of bands	"BAND_SEQUENTIAL"		
Number of lines of an image		LINES = %d	Number of pixels along the vertical axis of this scene.			
Number of line's samples of an image		LINE_SAMPLES = %d	Number of pixels along the horizontal axis of this scene.			
Sample type		SAMPLE_TYPE = "%s"	Sample type	"MSB_INTEGER"		
Sample bits		SAMPLE_BITS = %d	Sample bit length	16		
Image value type		IMAGE_VALUE_TYPE = "%s"	Image value type	"DN"[ND], "RADIANCE"[W/m2/micron/sr], "REFLECTANCE"[ND]		
Unit		UNIT = "%s"	Unit of sample value	"ND", "W/m**2/micron/sr", "ND"		
Scaling factor		SCALING_FACTOR = %8.5e	Conversion coefficient used for converting DN value into physical quantity (first order coefficient)			
Offset		OFFSET = %8.5e	Conversion coefficient used for converting DN value into physical quantity (constant term)			
Minimum for statistical image evaluation, D1		MIN_FOR_STATISTICAL_EVALUATION = (%d,%d,...)	Minimum DN value of output range for statistical evaluation of image quality, indicated as pixel value scaled and offset.			
Maximum for statistical image evaluation, D2		MAX_FOR_STATISTICAL_EVALUATION = (%d,%d,...)	Maximum DN value of output range for statistical evaluation of image quality, indicated as pixel value scaled and offset.			
Maximum DN		SCENE_MAXIMUM_DN = (%d,%d,...)	In this scene, maximum DN value in the target group excluded the following: a.dummy pixel filled onboard b.dummy pixel filled on the failure of restoration in the L2A process system c.pixel of element number disregarded from image evaluation and d.pixel whose DN value is less than threshold D1 e.pixel whose DN value is greater than threshold D2	When the number of samples for image quality assessment is 0, the value is set -1.		
Minimum DN		SCENE_MINIMUM_DN = (%d,%d,...)	In this scene, minimum DN value in the target group excluded the following: a.dummy pixel filled onboard b.dummy pixel filled on the failure of restoration in the L2A process system c.pixel of element number disregarded from image evaluation and d.pixel whose DN value is less than threshold D1 e.pixel whose DN value is greater than threshold D2	When the number of samples for image quality assessment is 0, the value is set -1.		
Average DN		SCENE_AVERAGE_DN = (%.1f,%.1f,...)	In this scene, average DN value in the target group excluded the following: a.dummy pixel filled onboard b.dummy pixel filled on the failure of restoration in the L2A process system c.pixel of element number disregarded from image evaluation and d.pixel whose DN value is less than threshold D1 e.pixel whose DN value is greater than threshold D2	When the number of samples for image quality assessment is 0, the value is set -1.		
Standard deviation DN	SCENE_STDEV_DN = (%.1f,%.1f,...)	In this scene, standard deviation DN value in the target group excluded the following: a.dummy pixel filled onboard b.dummy pixel filled on the failure of restoration in the L2A process system c.pixel of element number disregarded from image evaluation and d.pixel whose DN value is less than threshold D1 e.pixel whose DN value is greater than threshold D2	When the number of samples for image quality assessment is 0, the value is set -1.			
Mode DN in this scene	SCENE_MODE_DN = (%d,%d,...)	In this scene, mode DN value in the target group excluded the following: a.dummy pixel filled onboard b.dummy pixel filled on the failure of restoration in the L2A process system c.pixel of element number disregarded from image evaluation and d.pixel whose DN value is less than threshold D1 e.pixel whose DN value is greater than threshold D2	When the number of samples for image quality assessment is 0, the value is set -1.			

List 2.1-6 (2/2) Details of PDS label (TC MAP)

Region	Item name	Description format	Item explanation	value	
Description area of image data object format	Shaded area minimum D5	SHADOWED_AREA_MINIMUM = (%d,%d,...)	Minimum DN value of output range for shadow discrimination, indicated as integral value scaled and offset.		
	Shaded area maximum D6	SHADOWED_AREA_MAXIMUM = (%d,%d,...)	Maximum DN value of output range for shadow discrimination, indicated as integral value scaled and offset.		
	Shaded area percentage between D5 and D6	SHADOWED_AREA_PERCENTAGE = (%d,%d,...)	Shaded area percentage(round down after the decimal point).In this scene, pixel percentage whose DN value is between threshold D5 and threshold D6: a.dummy pixel filled onboard b.dummy pixel filled on the failure of restoration in the L2A process system c.pixel of element number disregarded from image evaluation	When the number of samples for image quality assessment is 0, the value is set -1.	
	Invalid type	INVALID_TYPE = ("%s", "%s", ...)	Invalid pixel type Registered in L2DB : three types of "saturation", "negative value after calibration" and "others" Not registered in L2DB : list of all calibrated and corrected error		
	Invalid value	INVALID_VALUE = (%d, %d, ...)	Invalid pixel value Registered in L2DB : three types of "saturation", "negative value after calibration" and "others" Not registered in L2DB : list of all calibrated and corrected error		
	Invalid pixels	INVALID_PIXELS = ((%d,%d,...),(%d,%d,...),...)	Invalid pixels Registered in L2DB : three types of "saturation", "negative value after calibration" and "others" Not registered in L2DB : list of all calibrated and corrected error		
	Value provided pixels out of bounds pixels before resampling	OUT_OF_IMAGE_BOUNDS_VALUE = %d	Value provided to the pixel originally not existing before resampling		
	Number of pixels out of bounds pixels before resampling	OUT_OF_IMAGE_BOUNDS_PIXELS = (%d,%d,...)	Number of pixel originally not existing before resampling		
	Stretched flag	STRETCHED_FLAG = %s	Flag to indicate whether a data has been stretched to be easily viewable for external output.	"FALSE"	
		END OBJECT = IMAGE			
	Description area of map projection		OBJECT = IMAGE_MAP_PROJECTION		
Map projection type		MAP_PROJECTION_TYPE = "%s"	Map projection type		
Coordinate system type		COORDINATE_SYSTEM_TYPE = "%s"	Fixed coordinate system of celestial body	"BODY-FIXED ROTATING"	
Coordinate system name		COORDINATE_SYSTEM_NAME = "%s"	Original point is mass center of celestial body, latitude is positive in northhemisphere and longitude is positive in east longitude.	"PLANETOCENTRIC"	
A axis radius		A_AXIS_RADIUS = %8.1f <km>	Lunar radius in a axis	1737.4 <km>	
B axis radius		B_AXIS_RADIUS = %8.1f <km>	Lunar radius in b axis	1737.4 <km>	
C axis radius		C_AXIS_RADIUS = %8.1f <km>	Lunar radius in c axis	1737.4 <km>	
First standard parallel		FIRST_STANDARD_PARALLEL = %f <deg>	the point of tangency between the sphere of the planet and the cone of the projection.	"N/A"except that map projection is LCC	
Second standard parallel		SECOND_STANDARD_PARALLEL = %f <deg>	the intersection lines between the sphere of the planet and the cone of the projection.	"N/A"except that map projection is LCC	
Positive longitude direction		POSITIVE_LONGITUDE_DIRECTION = "%s"	Positive direction of longitude	"EAST"	
Center latitude		CENTER_LATITUDE = %11.8f <deg>	Latitude being original point of coordinate system in map projection		
Center longitude		CENTER_LONGITUDE = %12.8f <deg>	Longitude being original point of coordinate system in map projection		
Reference latitude		REFERENCE_LATITUDE = %11.8f <deg>	the new zero latitude in a rotated spherical coordinate system that was used in a given map projection type.	"N/A"	
Reference longitude		REFERENCE_LONGITUDE = %12.8f <deg>	the zero longitude in a rotated spherical coordinate system that was used in a given map projection type.	"N/A"	
Line first pixel		LINE_FIRST_PIXEL = %d	Line number of upper end of this scene	1	
Line last pixel		LINE_LAST_PIXEL = %d	Line number of lower end of this scene		
Sample first pixel		SAMPLE_FIRST_PIXEL = %d	Sample number of left end of this scene	1	
Sample last pixel		SAMPLE_LAST_PIXEL = %d	Sample number of right end of this scene		
Map projection rotation		MAP_PROJECTION_ROTATION = %f	Rotation angle to map projection coordinate system of this scene	0.0	
Map resolution		MAP_RESOLUTION = %f	Map resolution <pixel/deg>		
Map scale		MAP_SCALE = %f <km/pixel>	Map scale <km/pixel>		
Maximum latitude		MAXIMUM_LATITUDE = %11.8f <deg>	Center latitude of northernmost pixel.		
Minimum latitude		MINIMUM_LATITUDE = %11.8f <deg>	Center latitude of southernmost pixel.		
Easternmost longitude		EASTERMOST_LONGITUDE = %12.8f <deg>	Center longitude of easternmost pixel.		
Westernmost longitude		WESTERNMOST_LONGITUDE = %12.8f <deg>	Center longitude of westernmost pixels.		
The line offset value from the map projection origin		LINE_PROJECTION_OFFSET = %f <pixel>	The vertical offset value from the map projection origin (line and sample 1,1)[pixel].		
The sample offset value from the map projection		SAMPLE_PROJECTION_OFFSET = %f <pixel>	The horizontal offset value from the map projection origin (line and sample 1,1)[pixel].		
		END OBJECT = IMAGE_MAP_PROJECTION			
Description area of process parameter			OBJECT = PROCESSING_PARAMETERS		
		Dark current correction coefficient file name	DARK_FILE_NAME = ("%s", "%s", {"%s", "%s"},...)	Dark current correction coefficient file name ("N/A" when not corrected). This keyword may be omitted.	
	Flat field correction coefficient file name	FLAT_FILE_NAME = ("%s", "%s", {"%s", "%s"},...)	Flat field correction coefficient file name ("N/A" when not corrected). This keyword may be omitted.		
	Coefficient file name of temperature dependency correction of transmittance efficiency	EFFIC_FILE_NAME = ("%s", "%s", {"%s", "%s"},...)	Coefficient file name of temperature dependency correction of transmittance efficiency ("N/A" when not corrected). This keyword may be omitted.		
	File name of non-linearity correction coefficient	NONLIN_FILE_NAME = ("%s", "%s", {"%s", "%s"},...)	File name of non-linearity correction coefficient ("N/A" when not corrected). This keyword may be omitted.		
	Radiance conversion coefficient	RAD_CNV_COEF = ((%f,%f,%f,...),(%f,%f,%f,...), <W/m**2/micron/sr>)	Radiance conversion coefficient:indicate all value every band [W/m2/micron/sr] ("N/A" when not converted). This keyword may be omitted.		
	Reflectance conversion coefficient	REF_CNV_COEF = (%f,%f,%f,...) <1/(W/m**2/micron/sr)>	Coefficient for converting into reflectance (solar radiance)[1/(W/m2/micron/sr)] ("N/A" when not converted)		
	Photometric standard geometry	STANDARD_GEOMETRY = (%.1f,%.1f,%.1f)	Standard values of incidence angle, and emission angle and phase angle for photometric correction.	(30.0, 0.0, 30.0)	
	Photometric correction identification	PHOTO_CORR_ID = "%s"	Photometric correction formula type	"USGS", "BROWN", "LISM_ORIGINAL", "N/A"	
	Photometric correction coefficient	PHOTO_CORR_COEF = ((%e,%e,%e,...),(%e,%e,%e,...),...)	Coefficient of photometric correction formula ("N/A" when not corrected)		
	Resampling method	RESAMPLING_METHOD = {"%s", "%s", ...}	Interpolation method of resampling	"Nearest Neighbor", "Bi-Linear", "Cubic Convolution"	
	Geometric data matching original TC-Ortho data mosaic file name	TCO_MOSAIC_FILE_NAME = ("%s", "%s", ...)	Source TC ortho data file name used for providing geometric data. This keyword may be omitted.	***.img	
	Geometric data matching original DTM data mosaic file name	DTM_MOSAIC_FILE_NAME = ("%s", "%s", ...)	Source DTM data file name used for providing geometric data. This keyword may be omitted.	***.dtm	
	Overlap selection identification	OVERLAP_SELECTION_ID = "%s"	Method for processing overlap.		
	Matching mosaic on creating map	MATCHING_MOSAIC = "%s"	Matching method	N/A, CORRELATION1, CORRELATION2, SSDA1, SSDA2, SSDA3, SSDA4	
	Dead pixel discrimination threshold	L2A_DEAD_PIXEL_THRESHOLD = (%d, %d, ...)	Maximum pixel value to judge as dead pixel on L2A image		
	L2A saturation threshold	L2A_SATURATION_THRESHOLD = (%d, %d, ...)	Minimum threshold value to judge as saturation on L2A image		
	Dark current corrected valid minimum threshold	DARK_VALID_MINIMUM = (%d,%d,...)	Minimum threshold to discriminate its validity as if it is negative value after dark current correction. It's indicated as physical quantity (real value). ("N/A" when not corrected)		
	Radiance conversion saturation threshold	RADIANCE_SATURATION_THRESHOLD = %f <W/m**2/micron/sr>	Minimum threshold to discriminate to be radiance conversion saturation. Indicate physical quantity (real value). ("N/A" when not converted)		
	Reflectance conversion saturation threshold	REF_SATURATION_THRESHOLD = %f <ND>	Minimum threshold to discriminate to be saturation after converting reflectance. It's indicated as physical quantity (real value). ("N/A" when not converted)		
	END OBJECT = PROCESSING_PARAMETERS				
	END				

(2) Geometric data object

Map is altitude geometric data object. The geometric data is format of binary two dimensional array data. The specifications of geometric data object are shown in the List 2.1-7

List 2.1-7 Specifications of binary two dimensional array data on geometric data object

Data type	Unit	Definition
Altitude	km	Distance from lunar radius sphere

Level	Number of bits	Type	Byte order
MAP	32	Real number	big endian

L2A data compressed / not compressed	Swath	Observation pattern	L2A valid pixels	Number of geometric data points in a line when being thinned
Compressed	Full	Monoscopic / stereoscopic	4096	586
	Nominal	Monoscopic / stereoscopic	3496	500
	Half	Monoscopic / stereoscopic	1744	250
Not compressed	Full	Monoscopic	3208	459
		Stereoscopic	1600	229
	Nominal	Monoscopic	3208	459
		Stereoscopic	1600	229
	Half	Monoscopic	1752	251
		Stereoscopic	1600	229

* On MAP, the number of pixels in a line differs by images.

(3)Image data object

Image data object of TC is the format of binary two dimensional array data. On MAP, the number of pixels in a line differs by images.

The specifications of TC image data object are shown in the List 2.1-8

List 2.1-8 Specifications of binary two dimensional array data on image data object

Process level	Data type	Unit	Remarks column
MAP	Reflectance *	ND	Integer value of image data is the value scaled and offset.

* In processing to create parameters for data calibration, there are the cases of difference in data type.

Number of bits	16
Type	Integral number
Byte order	big endian

L2A data compressed / not compressed	Swath	Observation pattern	Number of pixels in a line (L2B, L2C)
Compressed	Full	Monoscopic/stereoscopic	4096
	Nominal	Monoscopic/stereoscopic	3496
	Half	Monoscopic/stereoscopic	1744
Not compressed	Full	Monoscopic	3208
		Stereoscopic	1600
	Nominal	Monoscopic	3208
		Stereoscopic	1600
	Half	Monoscopic	1752
		Stereoscopic	1600

2.1.4 TC low resolution data file

Low resolution data file is the image file in binary two dimensional array data format created for MAP data set, not having the header, and is created by thinning image data object of MAP PDS produce file.

Because this data file is the one used for the internal process of L2DB system, even if you send the request of getting data to L2DB system and obtain RGC data set, it is not included in L2DB product obtained.

The specifications of low resolution data file are shown in the List 2.1-9.

List 2.1-9 Specification of low resolution data file

Data type	Reflectance [ND]: Integer value of pixel number is the value scaled and offset. (Pixel value of image data object of PDS product file is used as is.)
Resolution	128 [pixel/deg]
Area of image data	Same as MAP PDS product file image data object
Number of bits	16
Type	Integral number
Byte order	big endian

2.2 MI

RGC data set of MI is broken into the following 11 process levels and geometric correction options.

- L2B0data
- L2B2data
- L2C1data
- L2C2data
- L2C3data
- L2C4data
- L2C5data
- L3C2data
- L3C4data
- L3C4data
- L3C5data
- MAP data
- MSC data

Among above, in L2B0~L3C5 data, first 3 characters show process level and the last fourth character shows geometric correction option. MAP data, being data registered in L2DB as a MAP product, are created by mosaicking several L3C, MAP and MSC data (mosaic processing). MSC data, being mosaic data but not a map product, are created by mosaicking several L3C, MAP and MSC data.

RGC data set of MI is created by tar-archiving the following files.

- Catalog information file
- PDS product file
- tar object file
- PDS label
- Low resolution data file

In MI, MI-VIS has 5 bands and MI-NIR has 4 bands, and so total 5 bands of MI-VIS, total 4 bands of MI-NIR, or total 9 bands of MI are made one data set.

And depending on the process level and geometric correction option, some cases are that the images of respective bands of MI-VIS or MI-NIR are recorded in separate PDS product files, and the other cases are that total 5 bands of MI-VIS, total 4 bands of MI-NIR, or total 9 bands of MI are recorded together in one PDS product file in BSQ format (these cases are called “cubed”).

Among these, the PDS product files of L2B2, L2C2 but MAP data which are cubed are gzip-compressed and the PDS label specifying their contents is created in detached format. Then along with the catalog information file and the thumbnail file, those 4 files are tar-archived.

The PDS product files of MAP data are cubed, but not gzip-compressed and along with the catalog information file, the thumbnail file, and the low resolution data file, those 4 files are tar-archived.

In the List 2.2-1, on MI it shows whether to be cubed and tar-gzipped by respective process levels and geometric correction options.

List 2.2-1 Process level, geometric correction option, cubed and tar-gzipped on MI

Process level, geometric correction option	Cubed	Tar-gzipped
L2B2, L2C2, MAP	MI-VIS 5 bands cubed	Without being tar-gzipped
	MI-NIR 4 bands cubed	
	MI total 9 bands cubed	

In the Figure 2.2-1, the composition of MI RGC data set but MAP data set among cubed MI RGC data set is shown. In the Figure 2.2-2, the composition of RGC data set of MI MAP data is shown.

On aforesaid each file, the file nomenclature rules of L2B and L2C are described in the List 2.2-2, and ones of MAP is described in the List 2.2-3, and the details of each file are described below.

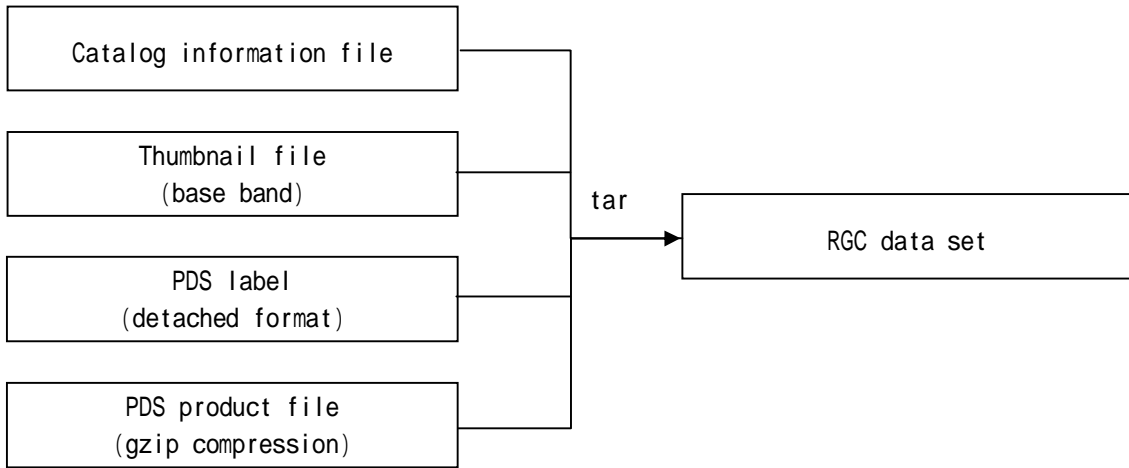

Figure 2.2-1 Composition of cubed MI RGC data set (L2B2, L2C2,)

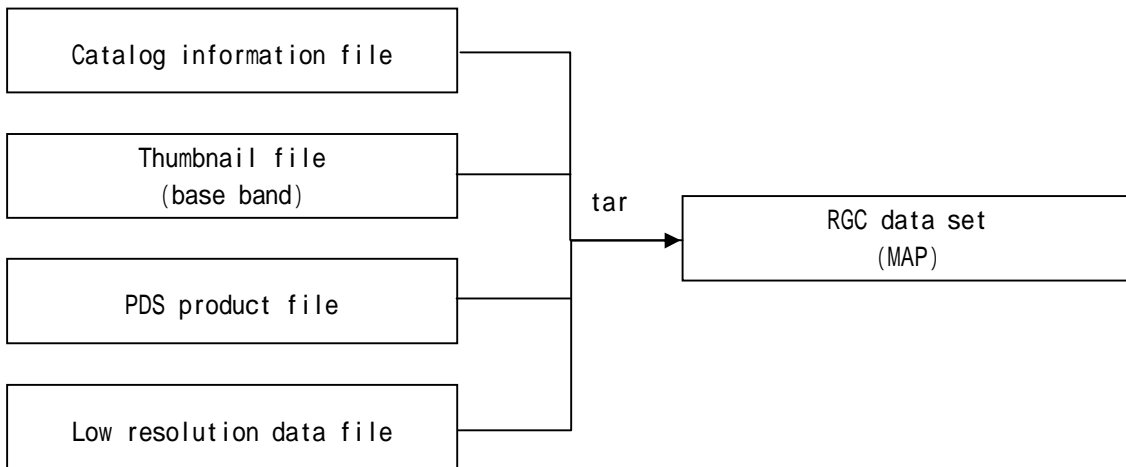

Figure 2.2-2 Composition of cubed MI RGC data set (MAP)

List 2.2-2 File nomenclature rule of MI (L2B, L2C)

No.	Starting position	Length(byte)	Set value
1	1	3	Sensor type MV1~MV5:MI-VIS1~5 MN1~MN4:MI-NIR1~4 MIA:MI total 9 bands MVA:MI-VIS total 5 bands MNA:MI-NIR total 4 bands
2	4	1	Underscore _:fixation
3	5	3	Process level / geometric correction option 2B2:2B2(level 2B·geometric correction option2) 2C2:2C2(level 2C·geometric correction option2)
4	8	1	Underscore _: fixation
5	9	2	Registered version in L2DB or individualized data set ID nn:2-digit number(registered version in L2DB) number and alphabet of big or small letters (individualized data set ID)
6	11	1	Underscore _:fixation
7	12	5	Lunar revolution number nnnnn:5-digit number
8	17	1	Discrimination of north or south hemisphere on latitude of the scene center N:North hemisphere S:South hemisphere
9	18	3	Latitude of the scene center(deg) nnn:3-digit number, round the second decimal place to one decimal place, but omit the decimal point nnn=000~900
10	21	5	Longitude of the scene center(deg) Ennnn:E shows east longitude nnnn:4-digit number, round the second decimal place to one decimal place, but omit the decimal point nnnn=0000~3600
11	26	2	Map projection (only for L3C) SC:Simple cylindrical projection MR:Mercator projection ML:Mollweide projection SN:Sinusoidal projection LM:Lambert conformal conic projection (1standard parallel) OR:Orthographic projection ST:Stereographic projection(including Polar stereo projection)
12	26 (L2B,L2C)	4	Extension .igz:RGC PDS product file(gzip compression) .jpg:thumbnail file .ctg:catalog information file .sl2:RGC data set
Total		29:L2B, L2C	

List 2.2-3 File nomenclature rule of MI (MAP)

No.	Starting position	Length (byte)	Set value
1	1	2	Sensor type MI:MI total 9 bands cubed MV:MI-VIS 5 bands cubed MN:MI-NIR 4 bands cubed
2	3	1	Underscore _: fixation
3	4	3	Process type MAP:MAP
4	7	1	Underscore _:fixation
5	8	2	Registered version in L2DB or individualized data set ID nn:2-digit number(registered version in L2DB) number and alphabet of big or small letters (individualized data set ID)
6	10	1	Underscore _: fixation
7	11	1	Discrimination of north or south hemisphere on north edge in the mosaic area N:North hemisphere S:South hemisphere
8	12	2	Latitude of north edge in the mosaic area (deg) nn:2-digit, only integer part round the first decimal place nn=00~90
9	14	4	Longitude of west edge in the mosaic area (deg) Ennn:E shows east longitude, nnn:3-digit, only integer part, round the first decimal place nnn=000~360
10	18	1	Discrimination of north or south hemisphere on south edge in the mosaic area N:North hemisphere S:South hemisphere
11	19	2	Latitude of south edge in the mosaic area (deg) nn:2-digit, only integer part, round the first decimal place nn=00~90
12	21	4	Longitude of east edge in the mosaic area (deg) Ennn:E shows east longitude, nnn:3-digit, only integer part, round the first decimal place nnn=000~360
13	25	2	Map projection (only for L3C) SC:Simple cylindrical projection MR:Mercator projection ML:Mollweide projection SN:Sinusoidal projection LM:Lambert conformal conic projection(1standard parallel) OR:Orthographic projection ST:Stereographic projection(including Polar stereo projection)
14	27 (other than divided mosaic)	4	Extension .img:RGC PDS product file(non-gzip compression) .jpg:thumbnail file .ctg:catalog information file .low:low resolution data file .sl2:RGC data set
Total		30:other than non-MAP divided mosaic	

2.2.1 MI catalog information file

Catalog information file is the information file attached to explain the general of RGC PDS product and is used to search for the product from L2DB subsystem.

The details of items in the catalog information file are shown in the list of List 2.2-4~List 2.2-9. In comment information, multiple items described in the list of details of items in catalog information file are recorded in the comma-delimited "keyword=value" form.

And on each item of catalog information, value is basis of zero suppression in the absence of mentioning of particular reference.

List 2.2-4 Details of items in catalog information file (MI L2B, L2C)

Item name	Keyword	Format of set value	Set contents
Data file name	DataFileName	AAAA...AAAA (up to 31-digit)	RGC PDS product name
Data file size	DataFileSize	NNNNNNNNNN (up to 12-digit)	RGC PDS product file size
Data file format	DataFileFormat	AAAA...AAAA (up to 16-digit)	RGC PDS product file format
Thumbnail file name	ThumbnailFileName	AAAA...AAAA (up to 31-digit)	Thumbnail file name
Thumbnail file size	ThumbnailFileSize	NNNNNNNNNN (up to 12-digit)	Thumbnail file size
Thumbnail file format	ThumbnailFileFormat	AAAA (up to 4-digit)	JPEG format
Instrument name	InstrumentName	AAAA...AAAA (up to 16-digit)	LISM
Processing level	ProcessingLevel	AAAA...AAAA (up to 16-digit)	Processing level
Product identification	ProductID	AAAA...AAAA (up to 30-digit)	MI-VIS_Level12B2, MI-NIR_Level12B2 MI_Level12B2 MI-VIS_Level12C2, MI-NIR_Level12C2 MI_Level12C2 MI-VIS_Level12C3, MI-NIR_Level12C3 MI_Level12C3 MI-VIS_Level12C4, MI-NIR_Level12C4 MI_Level12C4 MI-VIS_Level12C5, MI-NIR_Level12C5 MI_Level12C5 Others
Product version	ProductVersion	AAAA...AAAA (up to 16-digit)	nn: L2DB registered version
Access level	AccessLevel	N	Setting any value among following: 0:prohibition of overwriting 1:access permission given to the only core members in the instrument group 2:access permission given to the members in the instrument group 3:access permission given to the members in both the instrument group and the SELENE mission 4:access permission given to all users (opening to the public)
Start date and time of data	StartDateTime	yyyy-mm-ddT hh:mm:ss.sssssZ	Start date and time of this scene (same contents as "start time (UT)" of PDS label)
End date and time of data	EndDateTime	yyyy-mm-ddT hh:mm:ss.sssssZ	Stop date and time of this scene (same contents as "stop time (UT)" of PDS label)
Lunar revolution number	RevoNumber	NNNNNNNNN (up to 10-digit)	Lunar revolution number provided by LISM
Strip number	StripNumber	NNNNNNNNN (up to 10-digit)	Strip number
Scene number	SceneNumber	NNNNNNNNN (up to 10-digit)	Scene number
Location flag	LocationFlag	A	Direction of spacecraft orbit at the start time of this scene A: ascending D: descending N: involving north pole S: involving south pole W: involving both poles
Upper left latitude of this scene	UpperLeftLatitude	SNN.NNNNNN	[-90, 90]
Upper left longitude of this scene	UpperLeftLongitude	NNN.NNNNNN	[0, 360]
Upper right latitude of this scene	UpperRightLatitude	SNN.NNNNNN	[-90, 90]
Upper right longitude of this scene	UpperRightLongitude	NNN.NNNNNN	[0, 360]
Lower left latitude of this scene	LowerLeftLatitude	SNN.NNNNNN	[-90, 90]
Lower left longitude of this scene	LowerLeftLongitude	NNN.NNNNNN	[0, 360]
Lower right latitude of this scene	LowerRightLatitude	SNN.NNNNNN	[-90, 90]
Lower right longitude of this scene	LowerRightLongitude	NNN.NNNNNN	[0, 360]
Center latitude of this scene	SceneCenterLatitude	SNN.NNNNNN	[-90, 90]
Center longitude of this scene	SceneCenterLongitude	NNN.NNNNNN	[0, 360]
Comment information	CommentInfo	AAAA...AAAA (up to 4000-	Refer to the list 2.2-6
Free keyword	FreeKeyword		Refer to the list 2.2-5

List 2.2-5 Details of free keyword items in catalog information file (MI L2B, L2C)

Item name	Keyword	Type	Format of set value	Set contents
Incidence angle of the scene center	IncidenceAngle	Real value	SNN...N.NNN	Incidence angle of the scene center(lunar spherical approximation)[degree]
Emission angle of the scene center	EmissionAngle	Real value	SNN...N.NNN	Emission angle of the scene center(lunar spherical approximation)[degree]
Phase angle of the scene center	PhaseAngle	Real value	SNN...N.NNN	Phase angle of the scene center[degree]
Solar azimuth angle of the scene center	SolarAzimuthAngle	Real value	SNN...N.NNN	Solar azimuth angle of the scene center[degree]
Approximate spacecraft altitude	SpacecraftAltitude	Real value	SNN...N.NNN	Spacecraft altitude of the first line("distance between spacecraft and lunar gravitational center" minus average lunar radius)
Focal plane temperature	FocalPlaneTemperature	Real value	SNN...N.NN	Focal plane temperature of the first line
Number of saturated pixels	SaturatedPixels	Integral value	NNNN...NNN	Number of saturated pixels among invalid pixels
Maximum DN in this scene	SceneMaximumDN	Integral value	NNN...NNN	Image evaluation: maximum value of pixels in this scene
Average DN in this scene	SceneAverageDN	Real value	SNN...N.NNN	Image evaluation: average value of pixels in this scene
Standard deviation DN in this scene	SceneStdevDN	Real value	SNN...N.NNN	Image evaluation: standard deviation value of pixels in this scene
Mode DN in this scene	SceneModeDN	Integral value	NNN...NNN	Image evaluation: scene mode of pixels in this scene
Shadowed area percentage between D5 and D6	ShadowedAreaPercentage	Integral value	NN...N	Shadowed area percentage of pixels

List 2.2-6 Details of comment information in catalog information file (MI L2B, L2C)

Item name	Keyword	Format of set value	Set content
Product creation time	ProductCreationTime=%s	AAA(20 characters)	Product creation time
Source L2A data file name	SourceLevel2AFileName=%s"	AAA...AAA	All source L2A data file names used for creating this PDS product.
Mission phase name	MissionPhaseName=%s"	AAA...AAA	Mission phase name
Exposure mode identification	ExposureModeID = "%s"	AA...AA	Exposure mode identification
Upper left daytime flag of the start line	UpperLeftDaytimeFlag=%s"	AA...AA	Daytime flag of the pixel on the first column and the first line
Upper right daytime flag of the start line	UpperRightDaytimeFlag=%s"	AA...AA	Daytime flag of the pixel on the last column and the first line
Lower left daytime flag of the stop line	LowerLeftDaytimeFlag=%s"	AA...AA	Daytime flag of the pixel on the first column and the last line
Lower right daytime flag of the stop line	LowerRightDaytimeFlag=%s"	AA...AA	Daytime flag of the pixel on the last column and the last line
Roll cant	RollCant=%s"		YES: roll cant NO: nadir looking
Band number of base band	BaseBand=%s"		Base band identification (for L2B2,L2C2)

List 2.2-7 Details of items in catalog information file (MI MAP)

Item name	Keyword	Format of set value	Set contents
Data file name	DataFileName	AAAA...AAAA (up to 31-digit)	RGC PDS product name
Data file size	DataFileSize	NNNNNNNNNN (up to 12-digit)	RGC PDS product file size
Data file format	DataFileFormat	AAAA...AAAA (up to 16-digit)	RGC PDS product file format
Thumbnail file name	ThumbnailFileName	AAAA...AAAA (up to 31-digit)	Thumbnail file name
Thumbnail file size	ThumbnailFileSize	NNNNNNNNNN (up to 12-digit)	Thumbnail file size
Thumbnail file format	ThumbnailFileFormat	AAAA (up to 4-digit)	JPEG format
Instrument name	InstrumentName	AAAA...AAAA (up to 16-digit)	LISM
Processing level	ProcessingLevel	AAAA...AAAA (up to 16-digit)	Processing level
Product identification	ProductID	AAAA...AAAA (up to 30-digit)	MI_MAP, MI-VIS_MAP, MI-NIR_MAP Others
Product version	ProductVersion	AAAA...AAAA (up to 16-digit)	nn: L2DB registered version
Access level	AccessLevel	N	Setting any value among following: 0:prohibition of overwriting 1:access permission given to the only core members in the instrument group 2:access permission given to the members in the instrument group 3:access permission given to the members in both the instrument group and the SELENE mission 4:access permission given to all users (opening to the public)
Upper left latitude of this scene	UpperLeftLatitude	SNN.NNNNN	[-90, 90]
Upper left longitude of this scene	UpperLeftLongitude	NNN.NNNNN	[0, 360]
Upper right latitude of this scene	UpperRightLatitude	SNN.NNNNN	[-90, 90]
Upper right longitude of this scene	UpperRightLongitude	NNN.NNNNN	[0, 360]
Lower left latitude of this scene	LowerLeftLatitude	SNN.NNNNN	[-90, 90]
Lower left longitude of this scene	LowerLeftLongitude	NNN.NNNNN	[0, 360]
Lower right latitude of this scene	LowerRightLatitude	SNN.NNNNN	[-90, 90]
Lower right longitude of this scene	LowerRightLongitude	NNN.NNNNN	[0, 360]
Center latitude of this scene	SceneCenterLatitude	SNN.NNNNN	[-90, 90]
Center longitude of this scene	SceneCenterLongitude	NNN.NNNNN	[0, 360]
Comment information	CommentInfo	AAA...AAA (up to 4000-digit)	Refer to the list 2.2-12
Free keyword	FreeKeyword		Refer to the list 2.2-11

List 2.2-8 Details of free keyword items in catalog information file (MI MAP)

Item name	Keyword	Type	Format of set value	Set contents
Number of saturated pixels	SaturatedPixels	Integral value	NNN...NNN	Number of saturated pixels among invalid pixels
Maximum DN in this scene	SceneMaximumDN	Integral value	NNN...NNN	Image evaluation: maximum value of pixels in this scene
Average DN in this scene	SceneAverageDN	Real value	SNN...N.NNN	Image evaluation: average value of pixels in this scene
Standard deviation DN in this scene	SceneStdevDN	Real value	SNN...N.NNN	Image evaluation: standard deviation value of pixels in this scene
Mode DN in this scene	SceneModeDN	Integral value	NNN...NNN	Image evaluation: scene mode of pixels in this scene
Shadowed area percentage between D5 and D6	ShadowedAreaPercentage	Integral value	NN...N	Shadowed area percentage of pixels

B

List 2.2-9 Details of comment information in catalog information file (MI MAP)

Item name	Keyword	Format of set value	Set content
Product creation time	ProductCreationTime=%s	AAA(20 characters)	Product creation time
Source L2A data file name	SourceLevel2AFileName=%s*	AAA...AAA	All source L2A data file names used for creating this PDS product. When the number of CommentInfo is over 4000, the value is shortened into "%s...".
Mission phase name	MissionPhaseName=%s*	AAA...AAA	Mission phase name

B

2.2.2 MI thumbnail file

Thumbnail file is the reduced image of image data object included in RGC data set, and is the JPEG format image. In MI, among MI-VIS 5 bands and/or MI-NIR 4 bands included in the data set, data of one band are selected as the base band and only thumbnail of the base band is included in the data set.

And on the details of JPEG, refer to the reference books (2).

Depending on the moving direction of the spacecraft and ascending/descending of the orbit, a thumbnail image is rotated/reversed in such a way that upper part of it can be just about north direction and right of it can be just about east direction. Involving (a) pole(s), it is not rotated/reversed. On the details of a thumbnail image's rotation/reverse, refer to Appendix1.

The specifications of thumbnail are described in the List 2.2-10.

List 2.2-10 Specifications of thumbnail file

Number of horizontal pixels	Number of vertical pixels	File size	Format
512 or less	512 or less	100kb or less	8bitJPEG

When the size of image data object is smaller than the aforesaid size, the size of thumbnail file is the same as one of the image data object.

2.2.3 MI PDS label

Among RGC PDS product files of MI, the PDS product files of L2B2, L2C2 but MAP data set which are cubed, are created by gzip-compressing.

The details of PDS label in detached format are shown in the list of List 2.2-11

And on the case that the set value of PDS label is numeric value, if it does not fulfill maximum digit number, it is left-aligned by zero suppression in the absence of mentioning of particular reference.

List 2.2-11(1/2) Details of PDS label (MI L2B2, L2C2 detached (cubed))

Region	Item name	Description format	Item explanation	value
Prerequisite items for PDS header	PDS version identification	PDS_VERSION_ID = "%s"	PDS version identification	"PDS3"
	File record type	RECORD_TYPE = "%s"	File record type (prerequisite for L2DB registration)	"UNDEFINED"
	File name (L2DB regulation)	FILE_NAME = "%s"	File name (prerequisite for L2DB)(uniquely decidable file name, involving extension.)	***.tgz, ***.igz
	Product identification (PDS practice)	PRODUCT_ID = "%s"	File name(unique decidable file name, not involving extension)	***(no extension)
	Data file format identification	DATA_FORMAT = "%s"	Data file format identification (prerequisite for L2DB registration)	"PDS"
Area specifying object position	Archive file name	ARCHIVE_FILE = "%s"	File name TGZ or GZIP-compressed	***.tgz, ***.igz
	Archive type	ARCHIVE_TYPE = "%s"	Archive type	"GZIP", "TAR_GZIP"
	Archive file name	FILE_NAME = "%s"	Archive file name	***.tgz, ***.igz
	Archive file size	FILE_SIZE = %d <BYTES>	Archive file size	
	Number of archived files	ARCHIVED_FILES = %d	Number of archived files	
	Name of archived files	ARCHIVED_FILES_NAME = {"%s", "%s", "%s"}	Name of archived files	***.img
	Required storage bytes	REQUIRED_STORAGE_BYTES = %d <BYTES>	Total file size of archived file	
Product information	File attribute	SOFTWARE_NAME = "%s"	Software name used for creating PDS product	"RGC TC MI"
	Product attribute	SOFTWARE_VERSION = "%s"	Software version used for creating PDS product	n.n.n
Product information	Product attribute	PROCESS_VERSION_ID = "%s"	Process version identification (prerequisite for L2DB registration)	"L2B", "L2C"
	Product attribute	PRODUCT_CREATION_TIME = %s	Product creation time(UTC)	YYYY-MM-DDThh:mm:ssZ
Product information	Product attribute	PROGRAM_START_TIME = %s	Program start time (UTC)	YYYY-MM-DDThh:mm:ssZ
	Product attribute	PRODUCER_ID = "%s"	Data producer identification	"LISM"
Product information	Product attribute	PRODUCT_SET_ID = "%s"	PDS product set types (prerequisite for L2DB registration)	"MI-VIS_Level2B2", "MI-NIR_Level2B2", "MI_Level2B2", "MI-VIS_Level2C2", "MI-NIR_Level2C2", "MI_Level2C2", "Others"
	Product attribute	PRODUCT_VERSION_ID = "%s"	Product version registered for L2DB (prerequisite for L2DB registration)	"00" - "99"
Product information	Product attribute	REGISTERED_PRODUCT = "%s"	It's be set whether it was created as product for registration, regardless of success and failure of registration in L2DB.	"Y" or "N"
	Product attribute	LEVEL2A_FILE_NAME = {"%s", "%s", "%s"}	Source data file names used for creating this PDS product	***.img
Product information	Product attribute	LEVEL2B_FILE_NAME = {"%s", "%s", "%s"}	Source data file names used for creating this PDS product (for L2C2)	***.img
	Product attribute	SPICE_METAKERNEL_FILE_NAME = "%s"	SPICE metakernel file names used for creating PDS product	
Product information	Scene attribute	MISSION_NAME = "%s"	Mission name	"SELENE"
	Scene attribute	SPACECRAFT_NAME = "%s"	Spacecraft name	"SELENE-M"
Product information	Scene attribute	DATA_SET_ID = "%s"	Data set identification in which included this scene.	
	Scene attribute	INSTRUMENT_NAME = "%s"	Instrument name(full name) (prerequisite for L2DB registration)	MIV:"Multiband Imager Visible" MIN:"Multiband Imager Near Infrared" When 9 bands are cubed: "Multiband Imager"
Product information	Scene attribute	INSTRUMENT_ID = "%s"	Instrument identification	"MI-VIS", "MI-NIR", "MI"
	Scene attribute	MISSION_PHASE_NAME = "%s"	Mission phase name	(e.g. Nominal/Option)
Product information	Scene attribute	REVOLUTION_NUMBER = %d	Revolution number in which included this scene	
	Scene attribute	STRIP_SEQUENCE_NUMBER = %d	Strip sequence number while in revolution	
Product information	Scene attribute	SCENE_SEQUENCE_NUMBER = %d	Scene sequence number while in strip	
	Scene attribute	UPPER_LEFT_DAYTIME_FLAG = "%s"	Daytime flag of the pixel on the first column and the first line by the system geometric data	Day: illuminated Night: not illuminated
Product information	Scene attribute	UPPER_RIGHT_DAYTIME_FLAG = "%s"	Daytime flag of the pixel on the last column and the first line by the system geometric data	Day: illuminated Night: not illuminated
	Scene attribute	LOWER_LEFT_DAYTIME_FLAG = "%s"	Daytime flag of the pixel on the first column and the last line by the system geometric data	Day: illuminated Night: not illuminated
Product information	Scene attribute	LOWER_RIGHT_DAYTIME_FLAG = "%s"	Daytime flag of the pixel on the last column and the last line by the system geometric data	Day: illuminated Night: not illuminated
	Scene attribute	TARGET_NAME = "%s"	Observation target name of this strip	"MOON"(default)
Product information	Scene attribute	OBSERVATION_MODE_ID = "%s"	Observation mode identification	"NORMAL":normal "SUPPORT":support "NORMAL&SUPPORT":normal and support image mosaic in TC MAP/MS
	Scene attribute	SENSOR_DESCRIPTION = "%s"	Sensor description. (e.g.TC:scan mode, TC1/2relative mounting angle, element number of used detector, focal length, F value, IFOV, field of view angle, range of wavelengths, aperture, explanation of swath mode, explanation of compression mode, explanation of exposure mode, Bit number of AD converter)	
Product information	Scene attribute	SENSOR_DESCRIPTION2 = "%s"	Alternative sensor description	
	Scene attribute	DETECTOR_STATUS = {"TC1:%s", "TC2:%s", "MV:%s", "MN:%s", "SP:%s"}	ON/OFF of five respective power supplies(TC1,TC2,MI-VIS,MI-NIR,SP) on the scene center	"ON", "OFF"
Product information	Scene attribute	EXPOSURE_MODE_ID = "%s"	Exposure mode identification	"LONG", "MIDDLE", "SHORT"
	Scene attribute	LINE_EXPOSURE_DURATION = %10.6f <msec>	Exposure duration of the line. Default value uniquely decidable to the respective exposure mode.	"6.5": LONG "3.25": MIDDLE "1.625": SHORT
Product information	Scene attribute	SPACECRAFT_CLOCK_START_COUNT (TI) = %15.4f <sec>	Observation time of the first line of this scene (TI)	
	Scene attribute	SPACECRAFT_CLOCK_STOP_COUNT (TI) = %15.4f <sec>	Observation time of the last line of this scene (TI)	
Product information	Scene attribute	CORRECTED_SC_CLOCK_START_COUNT (TI) = %17.6f <sec>	Corrected observation time of the first line of this scene (TI)	
	Scene attribute	CORRECTED_SC_CLOCK_STOP_COUNT (TI) = %17.6f <sec>	Corrected observation time of the last line of this scene (TI)	
Product information	Scene attribute	START_TIME = %s	Observation time of the first line of this scene (UT) (six decimal places)	"yyyy-mm-ddThh:mm:ss.ssssssZ"
	Scene attribute	STOP_TIME = %s	Observation time of the last line of this scene (UT) (six decimal places)	"yyyy-mm-ddThh:mm:ss.ssssssZ"
Product information	Scene attribute	CORRECTED_START_TIME = %s	Corrected observation time of the first line of this scene (UT) (six decimal places)	"yyyy-mm-ddThh:mm:ss.ssssssZ"
	Scene attribute	CORRECTED_STOP_TIME = %s	Corrected observation time of the last line of this scene (UT) (six decimal places)	"yyyy-mm-ddThh:mm:ss.ssssssZ"
Product information	Scene attribute	LINE_SAMPLING_INTERVAL = %10.6f <msec>	Designed value of sampling interval	
	Scene attribute	CORRECTED_SAMPLING_INTERVAL = %10.6f <msec>	Corrected sampling interval with dividing the corrected interval time between first line and last line of strip into the number of lines.	
Product information	Scene attribute	UPPER_LEFT_LATITUDE = %10.6f <deg>	Latitude of pixel on upper left corner of this scene by the system geometric data. Center latitude of the pixel on the first column and the first line snn.nnnnnn	[-90.000000, 90.000000]
	Scene attribute	UPPER_LEFT_LONGITUDE = %10.6f <deg>	Longitude of pixel on upper left corner of this scene by the system geometric data. Center longitude of the pixel on the first column and the first line nnn.nnnnnn	[0.000000, 360.000000]
Product information	Scene attribute	UPPER_RIGHT_LATITUDE = %10.6f <deg>	Latitude of pixel on upper right corner of this scene by the system geometric data. Center latitude of the pixel on the last column and the first line snn.nnnnnn	[-90.000000, 90.000000]
	Scene attribute	UPPER_RIGHT_LONGITUDE = %10.6f <deg>	Longitude of pixel on upper right corner of this scene by the system geometric data. Center longitude of the pixel on the last column and the first line nnn.nnnnnn	[0.000000, 360.000000]
Product information	Scene attribute	LOWER_LEFT_LATITUDE = %10.6f <deg>	Latitude of pixel on lower left corner of this scene by the system geometric data. Center latitude of the pixel on the first column and the last line snn.nnnnnn	[-90.000000, 90.000000]
	Scene attribute	LOWER_LEFT_LONGITUDE = %10.6f <deg>	Longitude of pixel on lower left corner of this scene by the system geometric data. Center longitude of the pixel on the first column and the last line nnn.nnnnnn	[0.000000, 360.000000]
Product information	Scene attribute	LOWER_RIGHT_LATITUDE = %10.6f <deg>	Latitude of pixel on lower right corner of this scene by the system geometric data. Center latitude of the pixel on the last column and the last line snn.nnnnnn	[-90.000000, 90.000000]
	Scene attribute	LOWER_RIGHT_LONGITUDE = %10.6f <deg>	Longitude of pixel on lower right corner of this scene by the system geometric data. Center latitude of the pixel on the last column and the last line nnn.nnnnnn	[0.000000, 360.000000]

List 2.2-11(2/2) Details of PDS label (MI L2B2, L2C2 detached (cubed))

Region	Item name	Description format	Item explanation	value		
Product information	Scene attribute	Common to each instrument	Location flag	LOCATION_FLAG = "%s"	Information of spacecraft location Explanation on criteria for determining It is determined on the basis of the satellite argument of latitude, (which shall be the angle toward lunar center, between the ascending node and the current satellite position, and zero degree as passing through the ascending node) at the both observation times of the first line and the last line of the scene. A: Both are in the ascending side (>270 degrees or [0 degree, 90 degrees]) and do not exceed half of the rotation period. D: Both are in the descending side ([90 degrees, 270 degrees]) and do not exceed half of the rotation period. N: Between the two, 90 degrees is included and 270 degrees is not. S: Between the two, 270 degrees is included and 90 degrees is not. W: Between the two, 90 degrees and 270 degrees are both included.	A : ascending D : descending N : involving north pole S : involving south pole W : involving both poles
			Roll cant	ROLL_CANT = "%s"	Discrimination of nadir looking or roll cant observation YES : roll cant NO : nadir looking	
			Scene center latitude	SCENE_CENTER_LATITUDE = %10.6f <deg>	Latitude of the scene center by the system geometric data	[-90.000000, 90.000000]
			Scene center longitude	SCENE_CENTER_LONGITUDE = %10.6f <deg>	Longitude of the scene center by the system geometric data	[0.000000, 360.000000]
			Incidence angle of the scene center	INCIDENCE_ANGLE = %7.3f <deg>	Incidence angle of the scene center by the system geometric data (lunar spherical approximation)	[0.000, 180.000]
			Emission angle of the scene center	EMISSION_ANGLE = %7.3f <deg>	Emission angle of the scene center by the system geometric data (lunar spherical approximation)	[0.000, 180.000]
			Phase angle of the scene center	PHASE_ANGLE = %7.3f <deg>	Phase angle of the scene center by the system geometric data	[0.000, 180.000]
			Solar azimuth angle of the scene center	SOLAR_AZIMUTH_ANGLE = %7.3f <deg>	Solar azimuth angle of the scene center by the system geometric data	[0.000, 360.000]
			Distance between moon and sun	MOON_SUN_DISTANCE = %d <km>	Distance between moon and sun (for L2C2)	
			Focal plane temperature	FOCAL_PLANE_TEMPERATURE = %6.2f <degC>	Focal plane temperature of the first line	
			Telescope temperature	TELESCOPE_TEMPERATURE = %6.2f <degC>	Telescope temperature of the first line	
			Satellite moving direction	SATELLITE_MOVING_DIRECTION = "%s"	Moving direction of satellite	+1 : lead of +x plane -1 : lead of -x plane
			First sampled line position	FIRST_SAMPLED_LINE_POSITION = "%s"		"UPPERMOST"
			First detector element position	FIRST_DETECTOR_ELEMENT_POSITION = "%s"	Direction of the first detector element (the direction in this scene: LEFT)	"LEFT"
			Radius of lunar shape (a axis) nnn.nnn (indicate meter order)	A_AXIS_RADIUS = %.3f <km>	Lunar radius in a axis. nnn.nnn (indicate down to meter order)	
			Radius of lunar shape (b axis)	B_AXIS_RADIUS = %.3f <km>	Lunar radius in b axis. nnn.nnn (indicate down to meter order)	
			Radius of lunar shape (c axis)	C_AXIS_RADIUS = %.3f <km>	Lunar radius in c axis. nnn.nnn (indicate down to meter order)	
			Defect pixel position (=element number)	DEFECT_PIXEL_POSITION = ((%d,%d,...),(%d,%d,...),...)	The position of defect element (=element number) dealt as disregarded for image evaluation, as it has proved not to be available because of its defect (black or white) at launching of the process.	MI-VIS:1~962/(in 962 elements) MI-NIR:1~320/(in 320 elements)
			Variation by each instrument	Filter name	FILTER_NAME = ("%s" "%s" "%s")	Names of MI filters "MV1", "MV2", "MV3", "MV4", "MV5" "MN1", "MN2", "MN3", "MN4"
				Center filter wavelength	CENTER_FILTER_WAVELENGTH = (%.1f %.1f %.1f) <nm>	Center wavelength of the filter (nominal value)
			Bandwidth	BANDWIDTH = (%.1f %.1f %.1f) <nm>	Band width (full-width at half-maximum, nominal value)	
			Base band of MI	BASE_BAND = "%s"	Base band identification of MI "MV1", "MV2", "MV3", "MV4", "MV5" "MN1", "MN2", "MN3", "MN4"	
			Approximate spacecraft altitude	SPACECRAFT_ALTITUDE = %8.3f <km>	Spacecraft altitude of the first line ("distance between spacecraft and lunar gravitational center" minus average lunar radius)	
			Spacecraft ground speed	SPACECRAFT_GROUND_SPEED = %6.3f <km/sec>	Spacecraft ground speed of the first line	
				END		

2.2.4 MI PDS product file

RGC PDS product file of MI is the PDS file in attached format, and is composed of PDS label segment (header segment), geometric information object (after L2C), and image data object. PDS label is recorded in text format and geometric information object and image data object are recorded in binary format.

The composition of MI RGC PDS product file is shown in the Figure 2.2-3 and the format of MI RGC PDS product file is shown in the Figure 2.2-4.

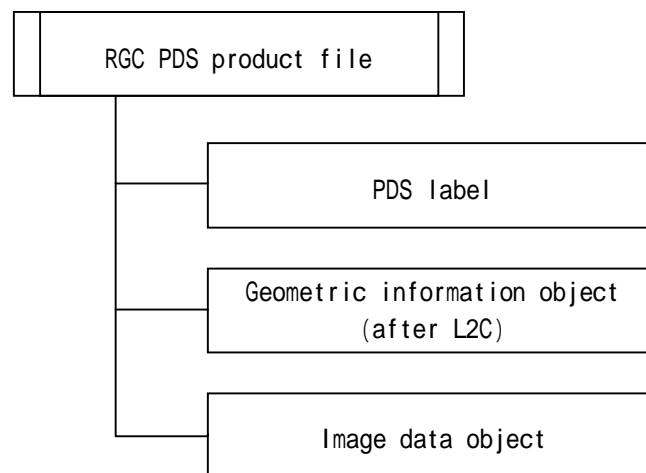

Figure 2.2-3 Composition of Mi RGC PDS product file

PDS label	<ul style="list-style-type: none"> Prerequisite items for PDS header Version identification 	
	<ul style="list-style-type: none"> Area specifying object position Pointer to all objects 	
	Product information	<ul style="list-style-type: none"> File attribute e.g. file name, creating date, update date
		<ul style="list-style-type: none"> Product attribute e.g. software name used for creating product, producer identification, source data file name
		<ul style="list-style-type: none"> Scene attribute Common to each instrument e.g. start time of the scene, stop time of the scene, observation mode name Variation by each instrument e.g. observation parameters, status
	<ul style="list-style-type: none"> Description area of geometric data object format (latitude·longitude: L2C, altitude: MAP) e.g. thinning interval of geometric data, number of data points in vertical and horizontal direction, bit length 	
	<ul style="list-style-type: none"> Description area of image data object format e.g. number of vertical and horizontal pixels of the scene, bit length 	
<ul style="list-style-type: none"> Geometric data object(latitude: L2C) Binary two dimensional array data 		
<ul style="list-style-type: none"> Geometric data object(longitude: L2C) Binary two dimensional array data 		
<ul style="list-style-type: none"> Geometric data object(altitude: MAP) Binary two dimensional array data 		
<ul style="list-style-type: none"> Image data object Binary two dimensional array data - When 5 bands of MI-VIS are cubed: recorded in BSQ format in order of 1,2,3,4,5 band - When 4 bands of MI-NIR are cubed: recorded in BSQ format in order of 1,2,3,4 band - When total 9 bands of MI are cubed: recorded in BSQ format in order of 1,2,3,4,5 on MI-VIS bands, and 1,2,3,4 on MI-NIR bands. 		

Figure 2.2-4 Format of MI RGC PDS product file

(1)PDS label

The details of PDS label of MI RGC PDS product file are shown in the list of List 2.2-12~List 2.2-14

And on the case that the set value of PDS label is numeric value, if it does not fulfill maximum digit number, it is left-aligned by zero suppression in the absence of mentioning of particular reference.

On the details of the invalid pixel, refer to Appendix2.

List 2.2-12(1/2) Details of PDS label (MI L2B2)

Region	Item name	Description format	Item explanation	Value	
Prerequisite items for PDS header	PDS version identification	POS_VERSION_ID = "%s"	PDS version identification	"POSS"	
	File record type	RECORD_TYPE = "%s"	File record type (prerequisite for L2B8 registration)	"UNDEFINED"	
	File name (L2B8 registration)	FILE_NAME = "%s"	File name (prerequisite for L2B8)(uniquely decidable file name, involving extension) (.img)	***.img	
	Product identification (PDS practice)	PRODUCT_ID = "%s"	Product identification (uniquely decidable file name, not involving extension)	***(no extension)	
Area specifying object position	Data file format identification	DATA_FORMAT = "%s"	Data file format identification (prerequisite for L2B8 registration)	"PDS"	
	Starting position of image object	^IMAGE = %d <BYTES>	Starting position of image object(in Byte)		
Product information	File attribute	Software name	SOFTWARE_NAME = "%s"	Software name used for creating PDS product	"RSC TC MI"
	Product attribute	Software version	SOFTWARE_VERSION_ID = "%s"	Software version used for creating PDS product	n.n.n
Scene attribute	Common to each instrument	Process version identification	PROCESS_VERSION_ID = "%s"	Process version identification (prerequisite for L2B8 registration)	"L2B"
		Product creation time	PRODUCT_CREATION_TIME = %s	Product creation time(UTC)	YYYY-MM-DDThh:mm:ssZ
Scene attribute	Common to each instrument	Program start time	PROGRAM_START_TIME = %s	Program start time (UTC)	YYYY-MM-DDThh:mm:ssZ
		Producer identification	PRODUCER_ID = "%s"	Data producer identification	"LISM"
Scene attribute	Common to each instrument	Product set identification	PRODUCT_SET_ID = "%s"	PDS product set types (prerequisite for L2B8 registration) The name in product list should be used. As of data not registered in L2B8, it's be described "Others".	"MI-VIS_Level2B2", "MI-NIR_Level2B2", "MI_Level2B2", "Others"
		Product version identification	PRODUCT_VERSION_ID = "%s"	Product version registered for L2B8 (prerequisite for L2B8 registration)	"00" - "99"
Scene attribute	Common to each instrument	Whether to be registered product in L2B8	REGISTERED_PRODUCT = "%s"	It's be set whether it was created as product for registration, regardless of success and failure of registration in L2B8.	"Y" or "N"
		Source data file name	LEVEL2A_FILE_NAME = ("%s", "%s", "%s")	Source data file names used for creating this PDS product	***.img
Scene attribute	Common to each instrument	SPICE metakernel file name	SPICE_METAKERNEL_FILE_NAME = "%s"	SPICE metakernel file names used for creating PDS product	
		Mission name	MISSION_NAME = "%s"	Mission name	"SELENE"
Scene attribute	Common to each instrument	Spacecraft name	SPACECRAFT_NAME = "%s"	Spacecraft name	"SELENE-M"
		Data set identification	DATA_SET_ID = "%s"	Data set identification in which included this scene	
Scene attribute	Common to each instrument	Instrument name	INSTRUMENT_NAME = "%s"	Instrument name (full name) (prerequisite for L2B8 registration)	"MIV:Multiband Imager Visible" "MIN:Multiband Imager Near Infrared" When 9 bands are cubed: "Multiband Imager"
		Instrument identification	INSTRUMENT_ID = "%s"	Instrument identification	"MI-VIS", "MI-NIR", "MI"
Scene attribute	Common to each instrument	Mission phase name	MISSION_PHASE_NAME = "%s"	Mission phase name	
		Resolution number	RESOLUTION_NUMBER = %d	Resolution number in which included this scene	(e.g. Nominal/Option)
Scene attribute	Common to each instrument	Strip sequence number	STRIP_SEQUENCE_NUMBER = %d	Strip sequence number while in revolution	
		Scene sequence number	SCENE_SEQUENCE_NUMBER = %d	Scene sequence number while in strip	
Scene attribute	Common to each instrument	Upper left daytime flag of the first line	UPPER_LEFT_DAYTIME_FLAG = "%s"	Daytime flag of the pixel on the first column and the first line by the system geometric data	Day: illuminated Night: not illuminated
		Upper right daytime flag of the first line	UPPER_RIGHT_DAYTIME_FLAG = "%s"	Daytime flag of the pixel on the last column and the first line by the system geometric data	Day: illuminated Night: not illuminated
Scene attribute	Common to each instrument	Lower left daytime flag of the last line	LOWER_LEFT_DAYTIME_FLAG = "%s"	Daytime flag of the pixel on the first column and the last line by the system geometric data	Day: illuminated Night: not illuminated
		Lower right daytime flag of the last line	LOWER_RIGHT_DAYTIME_FLAG = "%s"	Daytime flag of the pixel on the last column and the last line by the system geometric data	Day: illuminated Night: not illuminated
Scene attribute	Common to each instrument	Observation target name	TARGET_NAME = "%s"	Observation target name of this strip	"MOON (default)"
		Observation mode identification	OBSERVATION_MODE_ID = "%s"	Observation mode identification	"NORMAL":normal "SUPPORT":support "NORMALSUPPORT":normal and support image mosaic in TC MAP/USC
Scene attribute	Common to each instrument	Sensor description	SENSOR_DESCRIPTION = "%s"	Sensor description. (e.g.TC:scan mode, TC1/2relative mounting angle, element number of used detector, focal length, F value, IFOV, field of view angle, range of wavelengths, aperture, explanation of swath mode, explanation of compression mode, explanation of exposure mode, BIT number of AD converter)	
		Sensor description 2	SENSOR_DESCRIPTION2 = "%s"	Alternative sensor description	
Scene attribute	Common to each instrument	Sensor status	DETECTOR_STATUS = ("%s", "%s", "%s", "%s", "%s", "%s", "%s")	ON/OFF of five respective power supplies(TC1,TC2,MI-VIS,MI-NIR,SP) on the scene center	"ON", "OFF"
		Exposure mode	EXPOSURE_MODE_ID = "%s"	Exposure mode identification	"LONG", "MIDDLE", "SHORT"
Scene attribute	Common to each instrument	Exposure duration of the line	LINE_EXPOSURE_DURATION = %10.6f <sec>	Exposure duration of the line. Default value uniquely decidable to the respective exposure mode.	"0.5":LONG "3.25":MIDDLE "1.625":SHORT
		Spacecraft clock start count (TI)	SPACECRAFT_CLOCK_START_COUNT = %15.4f <sec>	Observation time of the first line of this scene (TI)	
Scene attribute	Common to each instrument	Spacecraft clock stop count (TI)	SPACECRAFT_CLOCK_STOP_COUNT = %15.4f <sec>	Observation time of the last line of this scene (TI)	
		Corrected spacecraft clock start count (TI)	CORRECTED_SC_CLOCK_START_COUNT = %17.6f <sec>	Corrected observation time of the first line of this scene (TI)	
Scene attribute	Common to each instrument	Corrected spacecraft clock stop count (TI)	CORRECTED_SC_CLOCK_STOP_COUNT = %17.6f <sec>	Corrected observation time of the last line of this scene (TI)	
		Start time (UT)	START_TIME = %s	Observation time of the first line of this scene (UT) (six decimal places)	"yyyy-mm-ddThh:mm:ss.sssss2"
Scene attribute	Common to each instrument	Stop time (UT)	STOP_TIME = %s	Observation time of the last line of this scene (UT) (six decimal places)	"yyyy-mm-ddThh:mm:ss.sssss2"
		Corrected start time (UT)	CORRECTED_START_TIME = %s	Corrected observation time of the first line of this scene (UT) (six decimal places)	"yyyy-mm-ddThh:mm:ss.sssss2"
Scene attribute	Common to each instrument	Corrected stop time (UT)	CORRECTED_STOP_TIME = %s	Corrected observation time of the last line of this scene (UT) (six decimal places)	"yyyy-mm-ddThh:mm:ss.sssss2"
		Sampling interval in the line	LINE_SAMPLING_INTERVAL = %10.6f <sec>	Designating line sampling interval	
Scene attribute	Common to each instrument	Corrected sampling interval	CORRECTED_SAMPLING_INTERVAL = %10.6f <sec>	Corrected sampling interval with dividing the corrected interval time between first line and last line of strip into the number of lines	
		Upper left latitude of this scene	UPPER_LEFT_LATITUDE = %10.6f <deg>	Latitude of pixel on upper left corner of this scene by the system geometric data. Center latitude of the pixel on the first column and the first line sn.nnnnnn	[-90.000000, 90.000000]
Scene attribute	Common to each instrument	Upper left longitude of this scene	UPPER_LEFT_LONGITUDE = %10.6f <deg>	Longitude of pixel on upper left corner of this scene by the system geometric data. Center longitude of the pixel on the first column and the first line nnn.nnnnnn	[0.000000, 360.000000]
		Upper right latitude of this scene	UPPER_RIGHT_LATITUDE = %10.6f <deg>	Latitude of pixel on upper right corner of this scene by the system geometric data. Center latitude of the pixel on the last column and the first line sn.nnnnnn	[-90.000000, 90.000000]
Scene attribute	Common to each instrument	Upper right longitude of this scene	UPPER_RIGHT_LONGITUDE = %10.6f <deg>	Longitude of pixel on upper right corner of this scene by the system geometric data. Center longitude of the pixel on the last column and the first line nnn.nnnnnn	[0.000000, 360.000000]
		Lower left latitude of this scene	LOWER_LEFT_LATITUDE = %10.6f <deg>	Latitude of pixel on lower left corner of this scene by the system geometric data. Center latitude of the pixel on the first column and the last line sn.nnnnnn	[-90.000000, 90.000000]
Scene attribute	Common to each instrument	Lower left longitude of this scene	LOWER_LEFT_LONGITUDE = %10.6f <deg>	Longitude of pixel on lower left corner of this scene by the system geometric data. Center longitude of the pixel on the first column and the last line nnn.nnnnnn	[0.000000, 360.000000]
		Lower right latitude of this scene	LOWER_RIGHT_LATITUDE = %10.6f <deg>	Latitude of pixel on lower right corner of this scene by the system geometric data. Center latitude of the pixel on the last column and the last line sn.nnnnnn	[-90.000000, 90.000000]
Scene attribute	Common to each instrument	Lower right longitude of this scene	LOWER_RIGHT_LONGITUDE = %10.6f <deg>	Longitude of pixel on lower right corner of this scene by the system geometric data. Center latitude of the pixel on the last column and the last line nnn.nnnnnn	[0.000000, 360.000000]
		Location flag	LOCATION_FLAG = "%s"	Information of spacecraft location Explanation on criteria for determining It is determined on the basis of the satellite argument of latitude, which shall be the angle toward lunar center, between the ascending node and the current satellite position, and zero degree as passing through the ascending node at the both observation times of the first line and the last line of the scene. A:Both are in the ascending side (>270 degrees or [0 degree, 90 degrees])and do not exceed half of the rotation period. D:Both are in the descending side (90 degrees, 270 degrees]) and do not exceed half of the rotation period. N:Between the two, 90 degrees is included and 270 degrees is not. S:Between the two, 270 degrees is included and 90 degrees is not. W:Between the two, 90 degrees and 270 degrees are both included.	A: ascending D: descending N: involving north pole S: involving south pole W: involving both poles
Scene attribute	Common to each instrument	Roll cant	ROLL_CANT = "%s"	Discrimination of nadir looking or roll cant observation	"YES":roll cant "NO":nadir looking
		Scene center latitude	SCENE_CENTER_LATITUDE = %10.6f <deg>	Latitude of the scene center by the system geometric data	[-90.000000, 90.000000]
Scene attribute	Common to each instrument	Scene center longitude	SCENE_CENTER_LONGITUDE = %10.6f <deg>	Longitude of the scene center by the system geometric data	[0.000000, 360.000000]
		Incidence angle of the scene center	INCIDENCE_ANGLE = %7.3f <deg>	Incidence angle of the scene center by the system geometric data (lunar spherical approximation)	[0.000, 180.000]
Scene attribute	Common to each instrument	Emission angle of the scene center	EMISSION_ANGLE = %7.3f <deg>	Emission angle of the scene center by the system geometric data (lunar spherical approximation)	[0.000, 180.000]
		Phase angle of the scene center	PHASE_ANGLE = %7.3f <deg>	Phase angle of the scene center by the system geometric data	[0.000, 180.000]
Scene attribute	Common to each instrument	Solar azimuth angle of the scene center	SOLAR_AZIMUTH_ANGLE = %7.3f <deg>	Solar azimuth angle of the scene center by the system geometric data	[0.000, 360.000]
		Focal plane temperature	FOCAL_PLANE_TEMPERATURE = %6.2f	Focal plane temperature of the first line	
Scene attribute	Common to each instrument	Telescope temperature	TELESCOPE_TEMPERATURE = %6.2f	Telescope temperature of the first line	
		Satellite moving direction	SATELLITE_MOVING_DIRECTION = "%s"	Moving direction of satellite	"1": lead of +x plane "-1": lead of -x plane "UPPERMOST"
Scene attribute	Common to each instrument	First sampled line position	FIRST_SAMPLED_LINE_POSITION = "%s"	Direction of the first detector element (the direction in this scene) LEFT	"LEFT"
		First detector element position	FIRST_DETECTOR_ELEMENT_POSITION = "%s"	Direction of the first detector element (the direction in this scene) LEFT	"LEFT"
Scene attribute	Common to each instrument	Radius of lunar shape (a axis) nnn.nnn (indicate down to m)	A_AXIS_RADIUS = %3.1f <km>	Lunar radius in a axis. nnn.nnn (indicate down to meter order)	
		Radius of lunar shape (b axis)	B_AXIS_RADIUS = %3.1f <km>	Lunar radius in b axis. nnn.nnn (indicate down to meter order)	
Scene attribute	Common to each instrument	Radius of lunar shape (c axis)	C_AXIS_RADIUS = %3.1f <km>	Lunar radius in c axis. nnn.nnn (indicate down to meter order)	
		Defect pixel position (=element number)	DEFECT_PIXEL_POSITION = (%d,%d,...), (%d,%d,...),...	The position of defect element (=element number) dealt as disregarded for image evaluation, as it has proved not to be available because of its defect (black or white) at launching of the process	MI-VIS:1-962/(in 962 elements) MI-NIR:1-320/(in 320 elements)
Scene attribute	Common to each instrument	Filter name	FILTER_NAME = ("%s", "%s", "%s")	Names of MI filters	"M1", "M2", "M3", "M4", "M5" "M11", "M12", "M13", "M14"
		Center filter wavelength	CENTER_FILTER_WAVELENGTH = (%.1f %f %f) <nm>	Center wavelength of the filter(nominal value)	
Scene attribute	Common to each instrument	Bandwidth	BANDWIDTH = (%.1f %f %f) <nm>	Band width(full width at half-maximum, nominal value)	
		Base band of MI	BASE_BAND = "%s"	Base band identification of MI	"M1", "M2", "M3", "M4", "M5" "M11", "M12", "M13", "M14"
Scene attribute	Common to each instrument	Approximate spacecraft altitude	SPACECRAFT_ALTITUDE = %8.3f <km>	Spacecraft altitude of the first line("distance between spacecraft and lunar gravitational center" minus average lunar radius)	
		Spacecraft ground speed	SPACECRAFT_GROUND_SPEED = %6.3f <km/sec>	Spacecraft ground speed of the first line	

List 2.2-12 (2/2) Details of PDS label (MI L2B2)

Region	Item name	Description format	Item explanation	value
Description area of image data object format		OBJECT = IMAGE		
	Number of nominal lines	NOMINAL_LINE_NUMBER = %d	Number of nominal lines in this scene(not including overlap lines)	
	Number of nominal overlap lines	NOMINAL_OVERLAP_LINE_NUMBER = %d	Number of nominal overlap lines in this scene	
	Number of overlap lines of back data	OVERLAP_LINE_NUMBER = %d	Number of real overlap lines (back part of data) If number of line is less than the number of nominal lines in this scene, it's described 0.	
	Number of bands	BANDS = %d	Number of bands	4, 5, 9
	Band storage type	BAND_STORAGE_TYPE = "%s"	Storage type of bands	"BAND_SEQUENTIAL"
	Number of lines of an image	LINES = %d	Number of pixels along the vertical axis of this scene(direction of along track)	
	Number of line's samples of an image	LINE_SAMPLES = %d	Number of pixels along the horizontal axis of this scene(direction of cross track · involving dummy elements on L2A(corresponding to the onboard dummy element), or value detached dummy elements filled onboard)	
	Sample type	SAMPLE_TYPE = "%s"	Sample type	"MSB_INTEGER"
	Sample bits	SAMPLE_BITS = %2d	Sample bit length	16
	Image value type	IMAGE_VALUE_TYPE = "%s"	Image value type	"DN"[ND], "RADIANCE"[W/m ² /micron/sr], "REFLECTANCE"[ND]
	Unit	UNIT = "%s"	Unit of sample value	"ND", "W/m ² /micron/sr"
	Scaling factor	SCALING_FACTOR = %8.5e	Conversion coefficient used for converting DN value into physical quantity (first order coefficient)	
	Offset	OFFSET = %8.5e	Conversion coefficient used for converting DN value into physical quantity (constant term)	
	Minimum for statistical image evaluation, D1	MIN_FOR_STATISTICAL_EVALUATION = (%d,%d,...)	Minimum DN value of output range for statistical evaluation of image quality, indicated as pixel value scaled and offset.	
	Maximum for statistical image evaluation, D2	MAX_FOR_STATISTICAL_EVALUATION = (%d,%d,...)	Maximum DN value of output range for statistical evaluation of image quality, indicated as pixel value scaled and offset.	
	Maximum DN	SCENE_MAXIMUM_DN = (%d,%d,...)	In this scene, maximum DN value in the target group excluded the following: a. dummy pixel filled onboard b. dummy pixel filled on the failure of restoration in the L2A process system c. pixel of element number disregarded from image evaluation and d. pixel whose DN value is less than threshold D1 e. pixel whose DN value is greater than threshold D2	When the number of samples for image quality assessment is 0, the value is set -1.
	Minimum DN	SCENE_MINIMUM_DN = (%d,%d,...)	In this scene, minimum DN value in the target group excluded the following: a. dummy pixel filled onboard b. dummy pixel filled on the failure of restoration in the L2A process system c. pixel of element number disregarded from image evaluation and d. pixel whose DN value is less than threshold D1 e. pixel whose DN value is greater than threshold D2	When the number of samples for image quality assessment is 0, the value is set -1.
	Average DN	SCENE_AVERAGE_DN = (%.1f,%d,...)	In this scene, average DN value in the target group excluded the following: a. dummy pixel filled onboard b. dummy pixel filled on the failure of restoration in the L2A process system c. pixel of element number disregarded from image evaluation and d. pixel whose DN value is less than threshold D1 e. pixel whose DN value is greater than threshold D2	When the number of samples for image quality assessment is 0, the value is set -1.
	Standard deviation DN	SCENE_STDEV_DN = (%.1f,%d,...)	In this scene, standard deviation DN value in the target group excluded the following: a. dummy pixel filled onboard b. dummy pixel filled on the failure of restoration in the L2A process system c. pixel of element number disregarded from image evaluation and d. pixel whose DN value is less than threshold D1 e. pixel whose DN value is greater than threshold D2	When the number of samples for image quality assessment is 0, the value is set -1.
	Mode DN in this scene	SCENE_MODE_DN = (%d,%d,...)	In this scene, mode DN value in the target group excluded the following: a. dummy pixel filled onboard b. dummy pixel filled on the failure of restoration in the L2A process system c. pixel of element number disregarded from image evaluation and d. pixel whose DN value is less than threshold D1 e. pixel whose DN value is greater than threshold D2	When the number of samples for image quality assessment is 0, the value is set -1.
	Shadowed area minimum D5	SHADOWED_AREA_MINIMUM = (%d,%d,...)	Minimum DN value of output range for shadow discrimination, indicated as integral value scaled and offset.	
	Shadowed area maximum D6	SHADOWED_AREA_MAXIMUM = (%d,%d,...)	Maximum DN value of output range for shadow discrimination, indicated as integral value scaled and offset.	
	Shadowed area percentage between D5 and D6	SHADOWED_AREA_PERCENTAGE = (%d,%d,...)	Shadowed area percentage(round down after the decimal point).In this scene, pixel percentage whose DN value is between threshold D5 and threshold D6: a. dummy pixel filled onboard b. dummy pixel filled on the failure of restoration in the L2A process system c. pixel of element number disregarded from image evaluation	When the number of samples for image quality assessment is 0, the value is set -1.
	Invalid type	INVALID_TYPE = ("%s", "%s", ...)	Invalid pixel type Registered in L2DB : three types of "saturation", "negative value after calibration" and "others" Not registered in L2DB: list of all calibrated and corrected error	
	Invalid value	INVALID_VALUE = (%d, %d, ...)	Invalid pixel value Registered in L2DB : three types of "saturation", "negative value after calibration" and "others" Not registered in L2DB: list of all calibrated and corrected error	
	Invalid pixels	INVALID_PIXELS = ((%d,%d,...), (%d,%d,...),...)	Invalid pixels Registered in L2DB : three types of "saturation", "negative value after calibration" and "others" Not registered in L2DB: list of all calibrated and corrected error	
	Value provided pixels out of bounds pixels before resampling	OUT_OF_IMAGE_BOUNDS_VALUE = %d	Value provided to the pixel originally not existing before resampling	
Number of pixels out of bounds pixels before	OUT_OF_IMAGE_BOUNDS_PIXELS = (%d,%d,...)	Number of pixel originally not existing before resampling		
	END OBJECT = IMAGE			
Description area of process parameter		OBJECT = PROCESSING PARAMETERS		
	Dark current correction coefficient file name	DARK_FILE_NAME = {"%s", "%s"}	Dark current correction coefficient file name ("N/A" when not corrected)	
	Frame transfer correction formula coefficient file	FT_FILE_NAME = "%s"	Frame transfer correction formula coefficient file name ("N/A" when not corrected)	
	Flat field correction coefficient file name	FLAT_FILE_NAME = {"%s", "%s"}	Flat field correction coefficient file name ("N/A" when not corrected)	
	Coefficient file name of temperature dependency correction of transmittance efficiency	EFFIC_FILE_NAME = {"%s", "%s"}	Coefficient file name of temperature dependency correction of transmittance efficiency ("N/A" when not corrected)	
	File name of non-linearity correction coefficient	NONLIN_FILE_NAME = {"%s", "%s"}	File name of non-linearity correction coefficient ("N/A" when not corrected)	
	Radiance conversion coefficient	RAD_CONV_COEF = (%f,%f,%f,...)<W/m ² /micron/sr>	Radiance conversion coefficient:indicate all value every band [W/m ² /micron/sr] ("N/A" when not converted)	
	Resampling method	RESAMPLING_METHOD = {"%s", "%s", ...}	Interpolation method of resampling	"Nearest Neighbor", "Bi-Linear", "Cubic Convolution"
	Dead pixel discrimination threshold	L2A_DEAD_PIXEL_THRESHOLD = (%d,%d,...)	Maximum pixel value to judge as dead pixel on L2A image	
	L2A saturation threshold	L2A_SATURATION_THRESHOLD = (%d,%d,...)	Minimum threshold value to judge as saturation on L2A image	
	Dark current corrected valid minimum threshold	DARK_VALID_MINIMUM = (%d,%d,...)	Minimum threshold to discriminate its validity as if it is negative value after dark current correction. It's indicated as physical quantity (real value). ("N/A" when not corrected)	
	Frame transfer corrected valid minimum threshold	FT_VALID_MINIMUM = %d	Minimum threshold to discriminate its validity if it is negative value after frame transfer correction. Indicate physical quantity (real value). ("N/A" when not corrected)	
	Radiance conversion saturation threshold	RADIANCE_SATURATION_THRESHOLD = %f	Minimum threshold to discriminate to be radiance conversion saturation. Indicate physical quantity (real value). ("N/A" when not converted)	
		END OBJECT = PROCESSING PARAMETERS		
		END		

List 2.2-13(1/2) Details of PDS label (MI L2C2)

Region	Item name	Description format	Item explanation	Value
Prerequisite items for PDS header	PDS version identification	PDS_VERSION_ID = "%s"	PDS version identification	"PDS3"
	File record type	RECORD_TYPE = "%s"	File record type (prerequisite for L20B registration)	"UNDEFINED"
	File name (L20B registration)	FILE_NAME = "%s"	File name (prerequisite for L20B) (uniquely decidable file name involving extension(.img))	"*.img"
	Product identification (PDS label)	PRODUCT_ID = "%s"	Product identification (uniquely decidable file name, not involving extension)	"*" (no extension)
Area specifying object position	Data file format identification	DATA_FORMAT = "%s"	Data file format identification (prerequisite for L20B registration)	"PDS"
	Starting position of geometric data (latitude)	GEOMETRIC_DATA_LATITUDE = %d <BYTES>	Starting position of geometric data (latitude) (in Byte)	
	Starting position of geometric data (longitude)	GEOMETRIC_DATA_LONGITUDE = %d <BYTES>	Starting position of geometric data (longitude) (in Byte)	
	Starting position of image object	IMAGE = %d <BYTES>	Starting position of image object (in Byte)	
Product information	File attribute	SOFTWARE_NAME = "%s" SOFTWARE_VERSION = "%s" PROCESS_VERSION_ID = "%s" PRODUCT_CREATION_TIME = %s PROGRAM_START_TIME = %s PRODUCER_ID = "%s"	Software name used for creating PDS product Software version used for creating PDS product Process version identification (prerequisite for L20B registration) Product creation time (UTC) Program start time (UTC) Data producer identification	"RSC TO MI" n.n.n "L2C" YYYY-MM-DDThh:mm:ssZ YYYY-MM-DDThh:mm:ssZ "L13H"
	Product attribute	PRODUCT_SET_ID = "%s" PRODUCT_VERSION_ID = "%s" REGISTERED_PRODUCT = "%s" LEVEL2A_FILE_NAME = ("%s", "%s", "%s") LEVEL2B_FILE_NAME = ("%s", "%s", "%s") SPICE_METAKERNEL_FILE_NAME = "%s"	PDS product set types (prerequisite for L20B registration) The name in product list should be used. As of data not registered in L20B, it's be described "Others" Product version registered for L20B (prerequisite for L20B registration) It's be set whether it was created as product for registration, regardless of success and failure of registration in L20B. Source data file names used for creating this PDS product Source data file names used for creating this PDS product SPICE metakernel file names used for creating PDS product	"MI-VIS_Level2C2", "MI-NIR_Level2C2", "MI_Level2C2", "Others" "00" - "99" "Y" or "N" *.img *.img
Scene attribute	Common to each instrument	MISSION_NAME = "%s"	Mission name	"SELENE"
		SPACECRAFT_NAME = "%s"	Spacecraft name	"SELENE-M"
		DATA_SET_ID = "%s"	Data set identification in which included this scene	"SELENE-M"
		INSTRUMENT_NAME = "%s"	Instrument name (full name) (prerequisite for L20B registration)	MI-VIS:Multiband Imager Visible MI-NIR:Multiband Imager Near Infrared MI-VIS-MI-NIR (e.g. Nominal/Option)
		INSTRUMENT_ID = "%s"	Instrument identification	
		MISSION_PHASE_NAME = "%s"	Mission phase name	
		REVOLUTION_NUMBER = %d	Revolution number in which included this scene	
		STRIP_SEQUENCE_NUMBER = %d	Strip sequence number while in revolution	
		SCENE_SEQUENCE_NUMBER = %d	Scene sequence number while in strip	
		UPPER_LEFT_DAYTIME_FLAG = "%s"	Daytime flag of the pixel on the first column and the first line by the system geometric data	Day: illuminated Night: not illuminated
		UPPER_RIGHT_DAYTIME_FLAG = "%s"	Daytime flag of the pixel on the last column and the first line by the system geometric data	Day: illuminated Night: not illuminated
		LOWER_LEFT_DAYTIME_FLAG = "%s"	Daytime flag of the pixel on the first column and the last line by the system geometric data	Day: illuminated Night: not illuminated
		LOWER_RIGHT_DAYTIME_FLAG = "%s"	Daytime flag of the pixel on the last column and the last line by the system geometric data	Day: illuminated Night: not illuminated
		TARGET_NAME = "%s"	Observation label name of this strip	"0001 (default)"
		OBSERVATION_MODE_ID = "%s"	Observation mode identification	"NORMAL:normal" "SUPPORT:support" "NORMAL&SUPPORT":normal and support image mosaic in TC MAP/MS2
		SENSOR_DESCRIPTION = "%s"	Sensor description (e.g. TC:scan node, TC1/2: relative mounting angle, element number of used detector, focal length, F value, IFOV, field of view angle, range of wavelengths, aperture, explanation of swath mode, explanation of compression mode, explanation of exposure mode Bit number of AD converter)	
		SENSOR_DESCRIPTION2 = "%s"	Alternative sensor description	
		DETECTOR_STATUS = ("%s", "%s", "%s", "%s", "%s", "%s")	ON/OFF of five respective power supplies (TC1, TC2, MI-VIS-MI-NIR, SP) on the scene center	"ON", "OFF"
		EXPOSURE_MODE_ID = "%s"	Exposure mode identification	"LONG", "MIDDLE", "SHORT"
		LINE_EXPOSURE_DURATION = %10.6f <ms>	Exposure duration of the line. Default value uniquely decidable to the respective exposure mode.	"6.5": LONG "3.25": MIDDLE "1.625": SHORT
		SPACECRAFT_CLOCK_START_COUNT = %15.4f <sec>	Observation time of the first line of this scene (TI)	
		SPACECRAFT_CLOCK_STOP_COUNT = %15.4f <sec>	Observation time of the last line of this scene (TI)	
		CORRECTED_SPACECRAFT_CLOCK_START_COUNT = %17.6f <sec>	Corrected observation time of the first line of this scene (TI)	
		CORRECTED_SPACECRAFT_CLOCK_STOP_COUNT = %17.6f <sec>	Corrected observation time of the last line of this scene (TI)	
		START_TIME = %s	Observation time of the first line of this scene (UT) (six decimal places)	"yyyy-mm-ddThh:mm:ss.sssssZ"
		STOP_TIME = %s	Observation time of the last line of this scene (UT) (six decimal places)	"yyyy-mm-ddThh:mm:ss.sssssZ"
		CORRECTED_START_TIME = %s	Corrected observation time of the first line of this scene (UT) (six decimal places)	"yyyy-mm-ddThh:mm:ss.sssssZ"
		CORRECTED_STOP_TIME = %s	Corrected observation time of the last line of this scene (UT) (six decimal places)	"yyyy-mm-ddThh:mm:ss.sssssZ"
		LINE_SAMPLING_INTERVAL = %10.6f <sec>	Desired value of sampling interval	
		CORRECTED_SAMPLING_INTERVAL = %10.6f <sec>	Corrected sampling interval with dividing the corrected interval time between first line and last line of strip into the number of lines	
		UPPER_LEFT_LATITUDE = %10.6f <deg>	Latitude of pixel on upper left corner of this scene by the system geometric data. Center latitude of the pixel on the first column and the first line snn.nnnnnn	[-90.000000, 90.000000]
		UPPER_LEFT_LONGITUDE = %10.6f <deg>	Longitude of pixel on upper left corner of this scene by the system geometric data. Center longitude of the pixel on the first column and the first line nnn.nnnnnn	[0.000000, 360.000000]
		UPPER_RIGHT_LATITUDE = %10.6f <deg>	Latitude of pixel on upper right corner of this scene by the system geometric data. Center latitude of the pixel on the last column and the first line snn.nnnnnn	[-90.000000, 90.000000]
		UPPER_RIGHT_LONGITUDE = %10.6f <deg>	Longitude of pixel on upper right corner of this scene by the system geometric data. Center longitude of the pixel on the last column and the first line nnn.nnnnnn	[0.000000, 360.000000]
		LOWER_LEFT_LATITUDE = %10.6f <deg>	Latitude of pixel on lower left corner of this scene by the system geometric data. Center latitude of the pixel on the first column and the last line snn.nnnnnn	[-90.000000, 90.000000]
		LOWER_LEFT_LONGITUDE = %10.6f <deg>	Longitude of pixel on lower left corner of this scene by the system geometric data. Center longitude of the pixel on the first column and the last line nnn.nnnnnn	[0.000000, 360.000000]
		LOWER_RIGHT_LATITUDE = %10.6f <deg>	Latitude of pixel on lower right corner of this scene by the system geometric data. Center latitude of the pixel on the last column and the last line snn.nnnnnn	[-90.000000, 90.000000]
		LOWER_RIGHT_LONGITUDE = %10.6f <deg>	Longitude of pixel on lower right corner of this scene by the system geometric data. Center longitude of the pixel on the last column and the last line nnn.nnnnnn	[0.000000, 360.000000]
		LOCATION_FLAG = "%s"	Information of spacecraft location Explanation on criteria for determining It is determined on the basis of the satellite argument of latitude, (which shall be the angle toward lunar center, between the ascending node and the current satellite position, and zero degree as passing through the ascending node) at the both observation times of the first line and the last line of the scene. A: Both are in the ascending side (>270 degrees or [0 degree, 90 degrees]) and do not exceed half of the rotation period. D: Both are in the descending side ([90 degrees, 270 degrees]) and do not exceed half of the rotation period. N: Between the two, 90 degrees is included and 270 degrees is not. S: Between the two, 270 degrees is included and 90 degrees is not. I: Between the two, 90 degrees and 270 degrees are both included.	A : ascending D : descending N : involving north pole S : involving south pole I : involving both poles
		ROLL_CANT = "%s"	Discrimination of nadir looking or roll cant observation	YES: roll cant NO: nadir looking
		SCENE_CENTER_LATITUDE = %10.6f <deg>	Latitude of the scene center by the system geometric data	[-90.000000, 90.000000]
		SCENE_CENTER_LONGITUDE = %10.6f <deg>	Longitude of the scene center by the system geometric data	[0.000000, 360.000000]
		INCIDENCE_ANGLE = %7.3f <deg>	Incidence angle of the scene center by the system geometric data (lunar spherical approximation)	[0.000, 180.000]
		EMISSION_ANGLE = %7.3f <deg>	Emission angle of the scene center by the system geometric data (lunar spherical approximation)	[0.000, 180.000]
		PHASE_ANGLE = %7.3f <deg>	Phase angle of the scene center by the system geometric data	[0.000, 180.000]
		SOLAR_AZIMUTH_ANGLE = %7.3f <deg>	Solar azimuth angle of the scene center by the system geometric data	[0.000, 360.000]
		MOON_SUN_DISTANCE = %d <km>	Distance between moon and sun	
		FOCAL_PLANE_TEMPERATURE = %6.2f	Focal plane temperature of the first line	
		TELESCOPE_TEMPERATURE = %6.2f	Telescope temperature of the first line	
		SATELLITE_MOVING_DIRECTION = "%s"	Moving direction of satellite	+1 : lead of +x plane -1 : lead of -x plane "UPPERMOST"
		FIRST_SAMPLED_LINE_POSITION = "%s"	Direction of the first detector element (the direction in this scene: LEFT)	"LEFT"
		FIRST_DETECTOR_ELEMENT_POSITION = "%s"	Direction of the first detector element (the direction in this scene: LEFT)	"LEFT"
		A_AXIS_RADIUS = %3.1f <km>	Lunar radius in a axis. nnn.nnn (indicate down to meter order)	
		B_AXIS_RADIUS = %3.1f <km>	Lunar radius in b axis. nnn.nnn (indicate down to meter order)	
		C_AXIS_RADIUS = %3.1f <km>	Lunar radius in c axis. nnn.nnn (indicate down to meter order)	
		DEFECT_PIXEL_POSITION = ((%d,%d,...), (%d,%d,...))	The position of defect element (=element number) dealt as disregarded for image evaluation, as it has proved not to be available because of its defect (black or white) at launching of the process.	MI-VIS:1-962/(in 962 elements) MI-NIR:1-320/(in 320 elements)
		FILTER_NAME = ("%s", "%s", "%s")	Names of MI filters	"MI1", "MI2", "MI3", "MI4", "MI5" "MI1", "MI2", "MI3", "MI4"
		CENTER_FILTER_WAVELENGTH = (%.1f, %.1f, %.1f) <nm>	Center wavelength of the filter (nominal value)	
		BANDWIDTH = (%.1f, %.1f, %.1f) <nm>	Band width (full-width at half-maximum, nominal value)	
		BASE_BAND = "%s"	Base band identification of MI	"MI1", "MI2", "MI3", "MI4", "MI5" "MI1", "MI2", "MI3", "MI4"
		SPACECRAFT_ALTITUDE = %8.3f <km>	Spacecraft altitude of the first line ("distance between spacecraft and lunar gravitational center" minus average lunar radius)	
		SPACECRAFT_GROUND_SPEED = %6.3f <km/sec>	Spacecraft ground speed of the first line	

List 2.2-13(2/2) Details of PDS label (MI L2C2)

Region	Item name	Description format	Item explanation	value	
Description area of geometric data (latitude) object format	Thinnig start pixel position	OBJECT = GEOMETRIC_DATA_LATITUDE BINNING_START_PIXEL_POSITION = (%d,%d)	Start pixel position for thinnig in this scene	(1,1)	
	Thinnig interval	BINNING_INTERVAL = %d	Thinnig interval		
	Number of lines	LINES = %d	Number of pixels along the vertical axis of this scene(direction of along track)		
	Number of line's samples	LINE_SAMPLES = %d	Number of pixels along the horizontal axis of this scene(direction of cross track + value detached dummy elements filled onboard)		
	Sample type	SAMPLE_TYPE = "%s"	Sample type	"IEEE_REAL"	
	Sample bits	SAMPLE_BITS = %d	Sample bit length	64	
	Unit	UNIT = "%s"	Unit of sample value	"deg"	
		END_OBJECT = GEOMETRIC_DATA_LATITUDE			
	Description area of geometric data (longitude) object format	Thinnig start pixel position	OBJECT = GEOMETRIC_DATA_LONGITUDE BINNING_START_PIXEL_POSITION = (%d,%d)	Start pixel position for thinnig in this scene	(1,1)
		Thinnig interval	BINNING_INTERVAL = %d	Thinnig interval	
Number of lines		LINES = %d	Number of pixels along the vertical axis of this scene(direction of along track)		
Number of line's samples		LINE_SAMPLES = %d	Number of pixels along the horizontal axis of this scene(direction of cross track + value detached dummy elements filled onboard)		
Sample type		SAMPLE_TYPE = "%s"	Sample type	"IEEE_REAL"	
Sample bits		SAMPLE_BITS = %d	Sample bit length	64	
Unit		UNIT = "%s"	Unit of sample value	"deg"	
		END_OBJECT = GEOMETRIC_DATA_LONGITUDE			
Description area of image data object format		Number of nominal lines	OBJECT = IMAGE NOMINAL_LINE_NUMBER = %d	Number of nominal lines in this scene(not including overlap lines)	
		Number of nominal overlap lines	NOMINAL_OVERLAP_LINE_NUMBER = %d	Number of nominal overlap lines in this scene	
	Number of overlap lines of back data	OVERLAP_LINE_NUMBER = %d	Number of real overlap lines (back part of data) If number of line is less than the number of nominal lines in this scene, it's described 0.		
	Number of bands	BANDS = %d	Number of bands	4,5,9	
	Band storage type	BAND_STORAGE_TYPE = "%s"	Storage type of bands	"BAND_SEQUENTIAL"	
	Number of lines of an image	LINES = %d	Number of pixels along the vertical axis of this scene(direction of along track)		
	Number of line's samples of an image	LINE_SAMPLES = %d	Number of pixels along the horizontal axis of this scene(direction of cross track + involving dummy elements on L2A(corresponding to the onboard dummy element), or value detached dummy elements filled onboard)		
	Sample type	SAMPLE_TYPE = "%s"	Sample type	"MSB_INTEGER"	
	Sample bits	SAMPLE_BITS = %d	Sample bit length	16	
	Image value type	IMAGE_VALUE_TYPE = "%s"	Image value type	"DN"[ND], "RADIANCE"[W/m ² /micron/sr], "REFLECTANCE"[ND]	
	Unit	UNIT = "%s"	Unit of sample value	"ND", "W/m ² /micron/sr", "ND"	
	Scaling factor	SCALING_FACTOR = %8.5e	Conversion coefficient used for converting DN value into physical quantity (first order coefficient)		
	Offset	OFFSET = %8.5e	Conversion coefficient used for converting DN value into physical quantity (constant term)		
	Minimum for statistical image evaluation, D1	MIN_FOR_STATISTICAL_EVALUATION = (%d,%d,...)	Minimum DN value of output range for statistical evaluation of image quality, indicated as pixel value scaled and offset.		
	Maximum for statistical image evaluation, D2	MAX_FOR_STATISTICAL_EVALUATION = (%d,%d,...)	Maximum DN value of output range for statistical evaluation of image quality, indicated as pixel value scaled and offset.		
	Maximum DN	SCENE_MAXIMUM_DN = (%d,%d,...)	In this scene, maximum DN value in the target group excluded the following: a. dummy pixel filled onboard b. dummy pixel filled on the failure of restoration in the L2A process system c. pixel of element number disregarded from image evaluation and d. pixel whose DN value is less than threshold D1 e. pixel whose DN value is greater than threshold D2	When the number of samples for image quality assessment is 0, the value is set -1.	
	Minimum DN	SCENE_MINIMUM_DN = (%d,%d,...)	In this scene, minimum DN value in the target group excluded the following: a. dummy pixel filled onboard b. dummy pixel filled on the failure of restoration in the L2A process system c. pixel of element number disregarded from image evaluation and d. pixel whose DN value is less than threshold D1 e. pixel whose DN value is greater than threshold D2	When the number of samples for image quality assessment is 0, the value is set -1.	
	Average DN	SCENE_AVERAGE_DN = (%.1f,%.1f,...)	In this scene, average DN value in the target group excluded the following: a. dummy pixel filled onboard b. dummy pixel filled on the failure of restoration in the L2A process system c. pixel of element number disregarded from image evaluation and d. pixel whose DN value is less than threshold D1 e. pixel whose DN value is greater than threshold D2	When the number of samples for image quality assessment is 0, the value is set -1.	
	Standard deviation DN	SCENE_STDEV_DN = (%.1f,%.1f,...)	In this scene, standard deviation DN value in the target group excluded the following: a. dummy pixel filled onboard b. dummy pixel filled on the failure of restoration in the L2A process system c. pixel of element number disregarded from image evaluation and d. pixel whose DN value is less than threshold D1 e. pixel whose DN value is greater than threshold D2	When the number of samples for image quality assessment is 0, the value is set -1.	
	Mode DN in this scene	SCENE_MODE_DN = (%d,%d,...)	In this scene, mode DN value in the target group excluded the following: a. dummy pixel filled onboard b. dummy pixel filled on the failure of restoration in the L2A process system c. pixel of element number disregarded from image evaluation and d. pixel whose DN value is less than threshold D1 e. pixel whose DN value is greater than threshold D2	When the number of samples for image quality assessment is 0, the value is set -1.	
	Shadowed area minimum D5	SHADOWED_AREA_MINIMUM = (%d,%d,...)	Minimum DN value of output range for shadow discrimination, indicated as integral value scaled and offset.		
	Shadowed area maximum D6	SHADOWED_AREA_MAXIMUM = (%d,%d,...)	Maximum DN value of output range for shadow discrimination, indicated as integral value scaled and offset.		
	Shadowed area percentage between D5 and D6	SHADOWED_AREA_PERCENTAGE = (%d,%d,...)	Shadowed area percentage(round down after the decimal point). In this scene, pixel percentage whose DN value is between threshold D5 and threshold D6: a. dummy pixel filled onboard b. dummy pixel filled on the failure of restoration in the L2A process system c. pixel of element number disregarded from image evaluation	When the number of samples for image quality assessment is 0, the value is set -1.	
Invalid type	INVALID_TYPE = ("%s", "%s", ...)	Invalid pixel type Registered in L2DB : three types of "saturation", "negative value after calibration" and "others" Not registered in L2DB : list of all calibrated and corrected error			
Invalid value	INVALID_VALUE = (%d, %d, ...)	Invalid pixel value Registered in L2DB : three types of "saturation", "negative value after calibration" and "others" Not registered in L2DB : list of all calibrated and corrected error			
Invalid pixels	INVALID_PIXELS = ((%d,%d,...), (%d,%d,...),...)	Invalid pixels Registered in L2DB : three types of "saturation", "negative value after calibration" and "others" Not registered in L2DB : list of all calibrated and corrected error			
Value provided pixels out of bounds pixels before resampling	OUT_OF_IMAGE_BOUNDS_VALUE = %d	Value provided to the pixel originally not existing before resampling			
Number of pixels out of bounds pixels before	OUT_OF_IMAGE_BOUNDS_PIXELS = (%d,%d,...)	Number of pixel originally not existing before resampling			
Description area of process parameter	Reflectance conversion coefficient	OBJECT = PROCESSING_PARAMETERS REF_DN_COEF = (%f,%f,%f,...)<1/(W/m ² /micron/sr)>	Coefficient for converting into reflectance (solar radiance)[1/(W/m ² /micron/sr)] ("N/A" when not converted)		
	Photometric standard geometry	STANDARD_GEOMETRY = (%.1f,%.1f,%.1f)	Standard values of incidence angle, and emission angle and phase angle for photometric correction.	(30.0, 0.0, 30.0)	
	Photometric correction identification	PHOTO_CORR_ID = "%s"	Photometric correction formula type	"USGS", "BROIN", "LISM_ORIGINAL", "N/A"	
	Photometric correction coefficient	PHOTO_CORR_COEF = ((%e,%e,%e,...), (%e,%e,%e,...),...)	Coefficient of photometric correction formula ("N/A" when not corrected)		
	Dead pixel discrimination threshold	L2A_DEAD_PIXEL_THRESHOLD = (%d,%d,...)	Maximum pixel value to judge as dead pixel on L2A image		
	L2A saturation threshold	L2A_SATURATION_THRESHOLD = (%d,%d,...)	Minimum threshold value to judge as saturation on L2A image		
	Dark current corrected valid minimum threshold	DARK_VALID_MINIMUM = (%d,%d,...)	Minimum threshold to discriminate its validity as if it is negative value after dark current correction. It's indicated as physical quantity (real value). ("N/A" when not corrected)		
	Frame transfer corrected valid minimum threshold	FT_VALID_MINIMUM = %d	Minimum threshold to discriminate its validity if it is negative value after frame transfer correction. Indicate physical quantity (real value). ("N/A" when not converted)		
	Radiance conversion saturation threshold	RADIANCE_SATURATION_THRESHOLD = %f	Minimum threshold to discriminate to be radiance conversion saturation. Indicate physical quantity (real value). ("N/A" when not converted)		
	Reflectance conversion saturation threshold	REF_SATURATION_THRESHOLD = %f<ND>	Minimum threshold to discriminate to be saturation after converting reflectance. It's indicated as physical quantity (real value). ("N/A" when not converted)		
		END_OBJECT = PROCESSING_PARAMETERS END			

List 2.2-14(1/2) Details of PDS label (MI MAP)

Region	Item name	Description format	Item explanation	value		
Prerequisite items for PDS header	PDS version identification	PDS_VERSION_ID = "%s"	PDS version identification	"PDS3"		
	File record type	RECORD_TYPE = "%s"	File record type (prerequisite for L2DB registration)	"UNDEFINED"		
	File name (L2DB regulation)	FILE_NAME = "%s"	File name (prerequisite for L2DB)(uniquely decidable file name, involving extension(.img))	***.img		
	Product identification (PDS practice)	PRODUCT_ID = "%s"	Product identification (uniquely decidable file name, not involving extension)	***(no extension)		
	Data file format identification	DATA_FORMAT = "%s"	Data file format identification (prerequisite for L2DB registration)	"PDS"		
Area specifying object position	Starting position of geometric data (altitude)	^GEOMETRIC_DATA_ALTITUDE = %d <BYTES>	Starting position of geometric data (altitude)(in Byte). This keyword may be omitted.			
	Starting position of image object	^IMAGE = %d <BYTES>	Starting position of image object(in Byte)			
Product information	File attribute	Software name	SOFTWARE_NAME = "%s"	Software name used for creating PDS product	"RGC TC MI"	
		Software version	SOFTWARE_VERSION = "%s"	Software version used for creating PDS product	n.n.n	
		Process version	PROCESS_VERSION_ID = "%s"	Process version identification (prerequisite for L2DB registration)	"MAP", "MSC"	
		Product creation time	PRODUCT_CREATION_TIME = %s	Product creation time(UTC)	YYYY-MM-DDThh:mm:ssZ	
		Program start time	PROGRAM_START_TIME = %s	Program start time (UTC)	YYYY-MM-DDThh:mm:ssZ	
	Product attribute	Producer identification	PRODUCER_ID = "%s"	Data producer identification	"LISM"	
		Product set identification	PRODUCT_SET_ID = "%s"	PDS product set types (prerequisite for L2DB registration) The name in product list should be used. As of data not registered in L2DB, it's be described "Others".	"MI_MAP", "MI-VIS_MAP", "MI-NIR_MAP", "Others"	
		Product version identification	PRODUCT_VERSION_ID = "%s"	Product version registered for L2DB (prerequisite for L2DB registration)	"00" ~ "99"	
		Whether to be registered product in L2DB	REGISTERED_PRODUCT = "%s"	It's be set whether it was created as product for registration, regardless of success and failure of registration in L2DB.	"Y" or "N"	
		Source data file name(L2A)	LEVEL2A_FILE_NAME = ({ "%s", "%s"}, {"%s", "%s"}, ...)	Source data file names used for creating this PDS product. This keyword may be omitted.	***.img	
	SPICE metakernel file name	SPICE_METAKERNEL_FILE_NAME = ("%s", "%s")	SPICE metakernel file names used for creating PDS product. This keyword may be omitted.			
	Scene attribute	Common to each instrument	Mission name	MISSION_NAME = "%s"	Mission name	"SELENE"
			Spacecraft name	SPACECRAFT_NAME = "%s"	Spacecraft name	"SELENE-M"
			Data set identification	DATA_SET_ID = "%s"	Data set identification in which included this scene.	
			Instrument name	INSTRUMENT_NAME = "%s"	Instrument name(full name) (prerequisite for L2DB registration)	MIV:"Multiband Imager Visible" MIN:"Multiband Imager Near Infrared" When 9 bands are cubed:"Multiband Imager"
Instrument identification			INSTRUMENT_ID = "%s"	Instrument identification	"MI-VIS", "MI-NIR", "MI"	
Variaton by each instrument		Observation target name	TARGET_NAME = "%s"	Observation target name of this strip	"MOON"(default)	
		Observation mode identification	OBSERVATION_MODE_ID = "%s"	Observation mode identification	"NORMAL":normal "SUPPORT":support "NORMAL&SUPPORT":normal and support image mosaic in TC_MAP/MSC	
		Sensor description	SENSOR_DESCRIPTION = "%s"	Sensor description. (e.g.TC:scan mode, TC1/2relative mounting angle, element number of used detector, focal length, F value, IFOV, field of view angle, range of wavelengths, aperture, explanation of swath mode, explanation of compression mode, explanation of exposure mode, Bit number of AD converter)		
		Sensor description 2	SENSOR_DESCRIPTION2 = "%s"	Alternative sensor description		
		Filter name	FILTER_NAME = ("%s", "%s", "%s")	Names of MI filters	"MV1", "MV2", "MV3", "MV4", "MV5" "MN1", "MN2", "MN3", "MN4"	
Description area of geometric data (altitude) object format	Center filter wavelength	CENTER_FILTER_WAVELENGTH = (%.1f, %.1f, %.1f) <nm>	Center wavelength of the filter(nominal value)			
	Bandwidth	BANDWIDTH = (%.1f, %.1f, %.1f) <nm>	Band width(full-width at half-maximum, nominal value)			
	Base band of MI	BASE_BAND = "%s"	Base band identification of MI	"MV1", "MV2", "MV3", "MV4", "MV5" "MN1", "MN2", "MN3", "MN4"		
	OBJECT = GEOMETRIC DATA ALTITUDE		This keyword may be omitted.			
	Thinnig start pixel position	BINNING_START_PIXEL_POSITION = (%d, %d)	Start pixel position for thinnig in this scene	(1,1)		
	Thinnig interval	BINNING_INTERVAL = %d	Thinnig interval			
	Number of lines	LINES = %d	Number of pixels along the vertical axis of this scene.			
	Number of line's samples	LINE_SAMPLES = %d	Number of pixels along the horizontal axis of this scene.			
	Sample type	SAMPLE_TYPE = "%s"	Sample type	"IEEE_REAL"		
	Sample bits	SAMPLE_BITS = %d	Sample bit length	32		
Unit	UNIT = "%s"	Unit of sample value	"km"			
Description area of image data object format	END OBJECT =					
	OBJECT = IMAGE					
	Number of bands	BANDS = %d	Number of bands	4,5,9		
	Band storage type	BAND_STORAGE_TYPE = "%s"	Storage type of bands	"BAND_SEQUENTIAL"		
	Number of lines of an image	LINES = %d	Number of pixels along the vertical axis of this scene.			
	Number of line's samples of an image	LINE_SAMPLES = %d	Number of pixels along the horizontal axis of this scene.			
	Sample type	SAMPLE_TYPE = "%s"	Sample type	"MSB_INTEGER"		
	Sample bits	SAMPLE_BITS = %d	Sample bit length	16		
	Image value type	IMAGE_VALUE_TYPE = "%s"	Image value type	"DN"[ND], "RADIANCE"[W/m2/micron/sr], "REFLECTANCE"[ND]		
	Unit	UNIT = "%s"	Unit of sample value	"ND", "W/m**2/micron/sr", "ND"		
	Scaling factor	SCALING_FACTOR = %8.5e	Conversion coefficient used for converting DN value into physical quantity (first order coefficient)			
	Offset	OFFSET = %8.5e	Conversion coefficient used for converting DN value into physical quantity (constant term)			
	Minimum for statistical image evaluation, D1	MIN_FOR_STATISTICAL_EVALUATION = (%d, %d, ...)	Minimum DN value of output range for statistical evaluation of image quality, indicated as pixel value scaled and offset.			
	Maximum for statistical image evaluation, D2	MAX_FOR_STATISTICAL_EVALUATION = (%d, %d, ...)	Maximum DN value of output range for statistical evaluation of image quality, indicated as pixel value scaled and offset.			
	Maximum DN	SCENE_MAXIMUM_DN = (%d, %d, ...)	In this scene, maximum DN value in the target group excluded the following: a. dummy pixel filled onboard b. dummy pixel filled on the failure of restoration in the L2A process system c. pixel of element number disregarded from image evaluation and d. pixel whose DN value is less than threshold D1 e. pixel whose DN value is greater than threshold D2	When the number of samples for image quality assessment is 0, the value is set -1.		
Minimum DN	SCENE_MINIMUM_DN = (%d, %d, ...)	In this scene, minimum DN value in the target group excluded the following: a. dummy pixel filled onboard b. dummy pixel filled on the failure of restoration in the L2A process system c. pixel of element number disregarded from image evaluation and d. pixel whose DN value is less than threshold D1 e. pixel whose DN value is greater than threshold D2	When the number of samples for image quality assessment is 0, the value is set -1.			
Average DN	SCENE_AVERAGE_DN = (%.1f, %.1f, ...)	In this scene, average DN value in the target group excluded the following: a. dummy pixel filled onboard b. dummy pixel filled on the failure of restoration in the L2A process system c. pixel of element number disregarded from image evaluation and d. pixel whose DN value is less than threshold D1 e. pixel whose DN value is greater than threshold D2	When the number of samples for image quality assessment is 0, the value is set -1.			
Standard deviation DN	SCENE_STDEV_DN = (%.1f, %.1f, ...)	In this scene, standard deviation DN value in the target group excluded the following: a. dummy pixel filled onboard b. dummy pixel filled on the failure of restoration in the L2A process system c. pixel of element number disregarded from image evaluation and d. pixel whose DN value is less than threshold D1 e. pixel whose DN value is greater than threshold D2	When the number of samples for image quality assessment is 0, the value is set -1.			
Mode DN in this scene	SCENE_MODE_DN = (%d, %d, ...)	In this scene, mode DN value in the target group excluded the following: a. dummy pixel filled onboard b. dummy pixel filled on the failure of restoration in the L2A process system c. pixel of element number disregarded from image evaluation and d. pixel whose DN value is less than threshold D1 e. pixel whose DN value is greater than threshold D2	When the number of samples for image quality assessment is 0, the value is set -1.			

List 2.2-14(2/2) Details of PDS label (MI MAP)

Region	Item name	Description format	Item explanation	value
Description area of image data object format	Shadowed area minimum D5	SHADOWED_AREA_MINIMUM = (%d,%d,...)	Minimum DN value of output range for shadow discrimination, indicated as integral value scaled and discrimination, indicated as integral value scaled and	
	Shadowed area maximum D6	SHADOWED_AREA_MAXIMUM = (%d,%d,...)	Maximum DN value of output range for shadow discrimination, indicated as integral value scaled and	
	Shadowed area percentage between D5 and D6	SHADOWED_AREA_PERCENTAGE = (%d,%d,...)	Shadowed area percentage(round down after the decimal point). In this scene, pixel percentage whose DN value is between threshold D5 and threshold D6: a.dummy pixel filled onboard b.dummy pixel filled on the failure of restoration in the L2A process system c.pixel of element number disregarded from image evaluation	When the number of samples for image quality assessment is 0, the value is set -1.
	Invalid type	INVALID_TYPE = ("%s", "%s", ...)	Invalid pixel type Registered in L2DB : three types of "saturation", "negative value after calibration" and "others" Not registered in L2DB: list of all calibrated and corrected error	
	Invalid value	INVALID_VALUE = (%d, %d, ...)	Invalid pixel value Registered in L2DB : three types of "saturation", "negative value after calibration" and "others" Not registered in L2DB: list of all calibrated and corrected error	
	Invalid pixels	INVALID_PIXELS = ((%d,%d,...),(%d,%d,...),...)	Invalid pixels Registered in L2DB : three types of "saturation", "negative value after calibration" and "others" Not registered in L2DB: list of all calibrated and corrected error	
	Value provided pixels out of bounds pixels before resampling	OUT_OF_IMAGE_BOUNDS_VALUE = %d	Value provided to the pixel originally not existing before resampling	
	Number of pixels out of bounds pixels before resampling	OUT_OF_IMAGE_BOUNDS_PIXELS = (%d,%d,...)	Number of pixel originally not existing before resampling	
	Stretched flag	STRETCHED_FLAG = %s	Flag to indicate whether a data has been stretched to be easily viewable for external output.	"FALSE"
		END OBJECT = IMAGE		
Description area of map projection		OBJECT = IMAGE MAP PROJECTION		
	Map projection type	MAP_PROJECTION_TYPE = "%s"	Map projection type	
	Coordinate system type	COORDINATE_SYSTEM_TYPE = "%s"	Fixed coordinate system of celestial body	"BODY-FIXED_ROTATING"
	Coordinate system name	COORDINATE_SYSTEM_NAME = "%s"	Original point is mass center of celestial body, latitude is positive in northern hemisphere and longitude is positive in east longitude.	"PLANETOCENTRIC"
	A axis radius	A_AXIS_RADIUS = %8.1f <km>	Lunar radius in a axis	1737.4 <km>
	B axis radius	B_AXIS_RADIUS = %8.1f <km>	Lunar radius in b axis	1737.4 <km>
	C axis radius	C_AXIS_RADIUS = %8.1f <km>	Lunar radius in c axis	1737.4 <km>
	First standard parallel	FIRST_STANDARD_PARALLEL = %f <deg>	the point of tangency between the sphere of the planet and the cone of the projection.	"N/A"except that map projection is LCC
	Second standard parallel	SECOND_STANDARD_PARALLEL = %f <deg>	the intersection lines between the sphere of the planet and the cone of the projection.	"N/A"except that map projection is LCC
	Positive longitude direction	POSITIVE_LONGITUDE_DIRECTION = "%s"	Positive direction of longitude	"EAST"
	Center latitude	CENTER_LATITUDE = %11.8f <deg>	Latitude being original point of coordinate system in map projection	
	Center longitude	CENTER_LONGITUDE = %12.8f <deg>	Longitude being original point of coordinate system in map projection	
	Reference latitude	REFERENCE_LATITUDE = %11.8f <deg>	the new zero latitude in a rotated spherical coordinate system that was used in a given	"N/A"
	Reference longitude	REFERENCE_LONGITUDE = %12.8f <deg>	the zero longitude in a rotated spherical coordinate system that was used in a given map projection type.	"N/A"
	Line first pixel	LINE_FIRST_PIXEL = %d	Line number of upper end of this scene	1
	Line last pixel	LINE_LAST_PIXEL = %d	Line number of lower end of this scene	
	Sample first pixel	SAMPLE_FIRST_PIXEL = %d	Sample number of left end of this scene	1
	Sample last pixel	SAMPLE_LAST_PIXEL = %d	Sample number of right end of this scene	
	Map projection rotation	MAP_PROJECTION_ROTATION = %f	Rotation angle to map projection coordinate system of this scene	0.0
	Map resolution	MAP_RESOLUTION = %f	Map resolution <pixel/deg>	
	Map scale	MAP_SCALE = %f <km/pixel>	Map scale <km/pixel>	
	Maximum latitude	MAXIMUM_LATITUDE = %11.8f <deg>	Center latitude of northernmost pixel.	
	Minimum latitude	MINIMUM_LATITUDE = %11.8f <deg>	Center latitude of southernmost pixel.	
	Easternmost longitude	EASTERNMOST_LONGITUDE = %12.8f <deg>	Center longitude of easternmost pixel.	
	Westernmost longitude	WESTERNMOST_LONGITUDE = %12.8f <deg>	Center longitude of westernmost pixel.	
	The line offset value from the map projection origin	LINE_PROJECTION_OFFSET = %f <pixel>	The vertical offset value from the map projection origin (line and sample 1.1)[pixel].	
	The sample offset value from the map projection	SAMPLE_PROJECTION_OFFSET = %f <pixel>	The horizontal offset value from the map projection origin (line and sample 1.1)[pixel].	
	END OBJECT = IMAGE MAP PROJECTION			
Description area of process parameter		OBJECT = PROCESSING PARAMETERS		
	Dark current correction coefficient file name	DARK_FILE_NAME = {"%s", "%s"}	Dark current correction coefficient file name ("N/A" when not corrected). This keyword may be omitted.	
	Frame transfer correction formula coefficient file name	FT_FILE_NAME = "%s"	Frame transfer correction formula coefficient file name ("N/A" when not corrected). This keyword may be omitted.	
	Flat field correction coefficient file name	FLAT_FILE_NAME = {"%s", "%s"}	Flat field correction coefficient file name ("N/A" when not corrected). This keyword may be omitted.	
	Coefficient file name of temperature dependency correction of transmittance efficiency	EFFIC_FILE_NAME = {"%s", "%s"}	Coefficient file name of temperature dependency correction of transmittance efficiency ("N/A" when not corrected). This keyword may be omitted.	
	File name of non-linearity correction coefficient	NONLIN_FILE_NAME = {"%s", "%s"}	File name of non-linearity correction coefficient ("N/A" when not corrected). This keyword may be omitted.	
	Radiance conversion coefficient	RAD_CNV_COEF = (%f,%f,%f,...)<W/m**2/micron/sr>	Radiance conversion coefficient:indicate all value every band [W/m2/micron/sr] ("N/A" when not converted). This keyword may be omitted.	
	Reflectance conversion coefficient	REF_CNV_COEF = (%f,%f,%f,...)<1/(W/m**2/micron/sr)>	Coefficient for converting into reflectance (solar radiance)[1/(W/m2/micron/sr)] ("N/A" when not converted)	
	Photometric standard geometry	STANDARD_GEOMETRY = (%.1f,%.1f,%.1f)	Standard values of incidence angle, and emission angle and phase angle for photometric correction.	(30.0, 0.0, 30.0)
	Photometric correction identification	PHOTO_CORR_ID = "%s"	Photometric correction formula type	"USGS", "BROWN", "LISM ORIGINAL", "N/A"
	Photometric correction coefficient	PHOTO_CORR_COEF = ((%e,%e,%e,...),(%e,%e,%e,...),...)	Coefficient of photometric correction formula ("N/A" when not corrected)	
	Resampling method	RESAMPLING_METHOD = {"%s", "%s", ...}	Interpolation method of resampling	"Nearest Neighbor", "Bi-Linear", "Cubic Convolution"
	Geometric data matching original TC-Ortho data mosaic file name	TCO_MOSAIC_FILE_NAME = "%s"	Source TC ortho data file name used for providing geometric data. This keyword may be omitted.	***.img
	Geometric data matching original DTM data mosaic file name	DTM_MOSAIC_FILE_NAME = "%s"	Source DTM data file name used for providing geometric data. This keyword may be omitted.	***.dtm
	Overlap selection identification	OVERLAP_SELECTION_ID = "%s"	Method for processing overlap.	
	Matching mosaic on creating map	MATCHING_MOSAIC = "%s"	Matching method	N/A,CORRELATION1,CORRELATION2,SSDA1,SSDA2,SSDA3,SSDA4
	Dead pixel discrimination threshold	L2A_DEAD_PIXEL_THRESHOLD = (%d, %d, ...)	Maximum pixel value to judge as dead pixel on L2A image	
	L2A saturation threshold	L2A_SATURATION_THRESHOLD = (%d, %d, ...)	Minimum threshold value to judge as saturation on L2A image	
	Dark current corrected valid minimum threshold	DARK_VALID_MINIMUM = (%d,%d,...)	Minimum threshold to discriminate its validity as if it is negative value after dark current correction. It's indicated as physical quantity (real value). ("N/A" when not corrected)	
	Frame transfer corrected valid minimum threshold	FT_VALID_MINIMUM = %d	Minimum threshold to discriminate its validity if it is negative value after frame transfer correction. Indicate physical quantity (real value). ("N/A" when not converted)	
	Radiance conversion saturation threshold	RADIANCE_SATURATION_THRESHOLD = %f	Minimum threshold to discriminate to be radiance conversion saturation. Indicate physical quantity (real value). ("N/A" when not converted)	
Reflectance conversion saturation threshold	REF_SATURATION_THRESHOLD = %f <ND>	Minimum threshold to discriminate to be saturation after converting reflectance. It's indicated as physical quantity (real value). ("N/A" when not converted)		
	END OBJECT = PROCESSING PARAMETERS			
	END			

(2)Geometric data object

MI geometric data object is the one given to after L2C product, and L2C2 is latitude and longitude data, and on MAP is altitude data object. These geometric data are format of binary two dimensional array data.

Geometric data of L2C2 is recorded after being thinned if all absolute values of the image latitude are not greater than 89 degree. Thinning interval is 8 pixels in Mi-VIS and 4 pixels in MI-NIR (default value, separately set as needed). When the number of horizontal or vertical pixels of the image is not “multiples of thinning interval plus 1”, they are maximum size of “multiples of thinning interval plus 1” in the image.

The specifications of geometric data object are shown in the List 2.2-15.

List 2.2-15 Specifications of binary two dimensional array data on geometric data object

Data type	Unit	Definition
Latitude	deg	-90~90
Longitude	deg	East longitude 0~360
Altitude	km	Distance from lunar radius sphere

Level	Number of bits	Type	Byte order
L2C	64	Real number	big endian
MAP	32	Real number	big endian

Sensor	Level/ geometric correction option	With or without thinning	Number of geometric data points in a line
MI-VIS	L2C2	with	121
		without	962
	MAP	without	Different by image
MI-NIR	L2C2	with	80
		without	320
	MAP	without	Different by image

(3)Image data object

Image data object of MI is the format of binary two dimensional array data. On MI RGC PDS product files, there is one image data object per one file regardless of with or without being cubed. On the case of cubed data set, the same number of image data as cubed bands are recorded in one image data object in BSQ format. On whether to be cubed by level/geometric correction options, refer to the List 2.2-1

The specifications of MI image data object are shown in the List 2.2-16.

List 2.2-16 Specifications of binary two dimensional array data on image data object

Process level	Data type	Unit	Remarks column
L2B	Radiance *	W/m ² /μm/sr	Integral value of image data is the value scaled and offset.
L2C, MAP,	Reflectance *	ND	

* In processing to create parameters for data calibration, there are the cases of difference in data type

Number of bits	16
Type	Integral number
Byte order	big endian

Sensor	Level/ geometric correction option	Number of pixels in a line
MI-VIS	L2B2, L2C2	962
	MAP	Different by image
MI-NIR	L2B2, L2C2	320
	MAP	Different by image

2.2.5 MI low resolution data file

Low resolution data file is the image file in binary two dimensional array data format created for MAP data set, not having the header, and is created by thinning image data object of all bands of MAP PDS product file.

Because this data file is the one used for the internal process of L2DB system, even if you send the request of getting data to L2DB system and obtain RGC data set, it is not included in L2DB product obtained.

The specifications of low resolution data file are shown in the List 2.2-17.

List 2.2-17 Specifications of low resolution data file

Data type	Reflectance [ND]: Integral value of pixel number is the value scaled and offset. (Pixel value of image data object of PDS product file is used as is.)
Resolution	128 [pixel/deg]
Area of image data	Same as MAP PDS product file image data object
Number of bits	16
Type	Integral number
Byte order	big endian

2.3 SP

RGC data set of SP is broken into the following 4 process levels.

- L2B1 data
- L2B2 data
- L2C data
- L2D data

RGC data set of SP is created by tar-archiving the following files. Depending on a parameter value, there are the cases that the original resolution JPEG image file is not included in the RGC data set of SP.

- Catalog information file
- Thumbnail file
- PDS product file
- Original resolution JPEG image file

Among above, the thumbnail file and the original resolution JPEG image file are not SP own data, but they are JPEG files generated from L2A data set of TC or MI acquired at the same time of SP observation, and is attached after L2B2.

In the Figure 2.3-1, the composition of SP L2B1 RGC data is shown and in the Figure 2.3-2, the one of SP L2B2, L2C and L2D RGC data set is shown.

On aforesaid each file, the file nomenclature rule is described in the List 2.3-1, List 2.3-2 and the details of each file are described below.

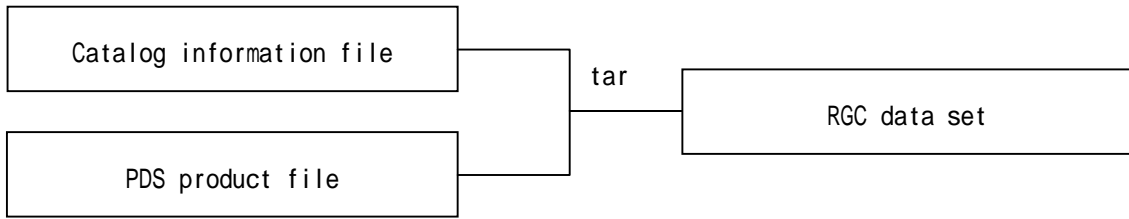
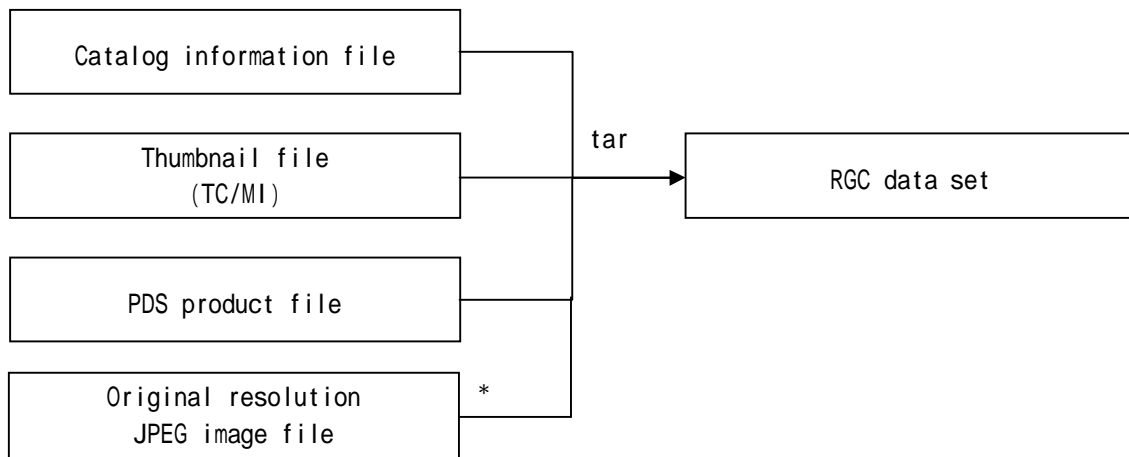

Figure 2.3-1 Composition of SP RGC data set (L2B1)



* There are some cases the original resolution JPEG image file is not included in the RGC data set of SP.

Figure 2.3-2 Composition of SP RGC data set (L2B2, L2C, L2D)

List 2.3-1 File nomenclature rule of SP (L2B1)

No.	Starting position	Length (byte)	Set value
1	1	3	Sensor type SP:fixation
2	4	3	Process level / geometric correction option 2B1:fixation
3	7	1	Underscore _:fixation
4	8	2	Registered version in L2DB or individualized data set ID nn:2-digit number(registered version in L2DB) number and alphabet of big or small letters (individualized data set ID)
5	10	1	Underscore _:fixation
6	11	5	Lunar revolution number nnnnn:5-digit number
7	16	1	Underscore _:fixation
8	17	1	Rev. number involving in product 1~9, Z (Z represents 10 and above)
9	18	1	Determination of day and night A~F, 2~9, Z A:night→day→night B:day only C:night→day D:day→night E:night only F:failure to determine day/night in all lines 2~9, Z:number of days(Z represents 10 and above)
10	19	1	Lightning of calibration lamp N, B, R, W N:non-lightning B:lightning of both radiance lamp and wavelength lamp R:lightning of only radiance lamp W:lightning of only wavelength lamp
11	20	1	Number of L2A scene on high resolution mode 0~9, Z (Z represents 10 and above)
12	21	5	Longitude of the point of lowest latitude in dayside Ennnnn:E shows east longitude E00000~E35999 (two decimal places, but omit decimal point) NIGHT_ (when all lines are in nightside)
13	26	1	With or without roll cant operation N, R N:without roll cant R:with roll cant
14	27	4	Extension .spc:RGC PDS product file .ctg:catalog information file .sl2:RGC data set
Total		30	

List 2.3-2 File nomenclature rule of SP (L2B2, L2C, L2D)

No.	Starting position	Length(byte)	Set value
1	1	3	Sensor type SP_:fixation
2	4	3(2)	Process level / geometric correction option 2B2:2B2(level 2B2) 2C :2C (level 2C) 2D :2D (level 2D)
3	7(6)	1	Underscore _:fixation
4	8(7)	2	Registered version in L2DB or individualized data set ID nn:2-digit number(registered version in L2DB) number and alphabet of big or small letters (individualized data set ID)
5	10(9)	1	Underscore _:fixation
6	11(10)	5	Lunar revolution number nnnn:5-digit number
7	16(15)	1	Underscore _:fixation
8	17(16)	1	Discrimination of north or south hemisphere on latitude of the data column center N:North hemisphere S:South hemisphere
9	18(17)	3	Latitude of the data column center(deg) nnn:3-digit number, round the second decimal place to one decimal place, but omit the decimal point nnn=000~900
10	21(20)	1	Underscore _:fixation
11	22(21)	5	Longitude of the data column center(deg) Ennnn:E shows east longitude nnnn:4-digit number, round the second decimal place to one decimal place, but omit the decimal point nnnn=0000~3600
12	27(26)	4	Extension .spc:RGC PDS product file .jpg:thumbnail file(after L2B2) .ctg:catalog information file .sl2:RGC data set
Total		30:L2B2 29:L2C, L2D	

The numbers out of () in the columns of "Starting Position" and "Length(byte)" are the case of L2B2, and the numbers in () are the cases of L2C and L2D.

The original resolution JPEG image file is named according to the file nomenclature rule of the thumbnail file. But "P" is added before extension.

2.3.1 SP catalog information file

Catalog information file is the information file attached to explain the general of RGC PDS product and is used to search for product from L2DB subsystem.

The details of items in the catalog information file are shown in the list of List 2.3-3. In the List 2.3-4, the details of free keyword items are shown.

And on each item of catalog information, value is basis of zero suppression in the absence of mentioning of particular reference.

List 2.3-3 Details of items in SP catalog information file

Item name	Keyword	Format of set value	Set contents
Data file name	DataFileName	AAAA...AAAA (up to 31-digit)	RGC PDS product name
Data file size	DataFileSize	NNNNNNNNNN (up to 12-digit)	RGC PDS product file size
Data file format	DataFileFormat	AAAA...AAAA (up to 16-digit)	RGC PDS product file format
Thumbnail file name ^{*1)}	ThumbnailFileName	AAAA...AAAA (up to 31-digit)	Thumbnail file name (after L2B2)
Thumbnail file size ^{*1)}	ThumbnailFileSize	NNNNNNNNNN (up to 12-digit)	Thumbnail file size (after L2B2)
Thumbnail file format ^{*1)}	ThumbnailFileFormat	AAAA (up to 4-digit)	JPEG:fixation (after L2B2)
Instrument name	InstrumentName	AAAA...AAAA (up to 16-digit)	LISM:fixation
Processing level	ProcessingLevel	AAAA...AAAA (up to 16-digit)	L2B1:L2B L2B2:L2B L2C :L2C L2D :L2D Others:Others
Product identification	ProductID	AAAA...AAAA (up to 30-digit)	SP_Level2B1:L2B1 SP_Level2B2:L2B2 SP_Level2C :L2C SP_Level2D :L2D Others:Others
Product version	ProductVersion	AAAA...AAAA (up to 16-digit)	nn:L2DB registered version
Access level	AccessLevel	N	Setting any value among following: 0:prohibition of overwriting 1:access permission given to the only core members in the instrument group 2:access permission given to the members in the instrument group 3:access permission given to the members in both the instrument group and the SELENE mission 4:access permission given to all
Start date and time of data	StartDateTime	yyyy-mm-ddT hh:mm:ss.sssssZ	Start date and time of this scene (same contents as "start time (UT)" of PDS label)
End date and time of data	EndDateTime	yyyy-mm-ddT hh:mm:ss.sssssZ	Stop date and time of this scene (same contents as "stop time (UT)" of PDS label)
Lunar revolution number	RevoNumber	NNNNNNNN (up to 10-digit)	Lunar revolution number provided by LISM
Strip number	StripNumber	NNNNNNNN (up to 10-digit)	Strip number
Scene number	SceneNumber	NNNNNNNN (up to 10-digit)	Scene number
Location flag	LocationFlag	A	Direction of the spacecraft orbit at the start time of this scene A:ascending D:descending N:involving north pole S:involving south pole W:involving both poles
Upper left latitude of the scene	UpperLeftLatitude	SNN.NNNNNN	[-90, 90]
Upper left longitude of the scene	UpperLeftLongitude	NNN.NNNNNN	[0, 360]
Upper right latitude of the scene	UpperRightLatitude	SNN.NNNNNN	[-90, 90]
Upper right longitude of the scene	UpperRightLongitude	NNN.NNNNNN	[0, 360]
Lower left latitude of the scene	LowerLeftLatitude	SNN.NNNNNN	[-90, 90]
Lower left longitude of the scene	LowerLeftLongitude	NNN.NNNNNN	[0, 360]
Lower right latitude of the scene	LowerRightLatitude	SNN.NNNNNN	[-90, 90]
Lower right longitude of the scene	LowerRightLongitude	NNN.NNNNNN	[0, 360]
Free keyword	FreeKeyword		Refer to the list 2.3-3

*1)Data of thumbnail file is not output in L2B1

List 2.3-4 Details of free keyword items in SP catalog information file

Item name	Keyword	Type	Format of set value	Set contents
Observation mode	ObservationMode	Character string	AAAA (up to 4-digit)	OBS : observation DARK : dark LAMP : calibration
Resolution	Resolution	Character string	AA···AA (up to 6-digit)	NORMAL : normal HIGH : high spatial resolution
Rollcant	RollCant	Character string	AAA (up to 3-digit)	YES/NO

2.3.2 SP thumbnail file

Thumbnail file of SP data set is not SP own data, but is attached as a JPEG file made from L2A data set of TC or MI acquired at the same time of SP observation to show the location on the moon observed by SP. Before that, the image in the L2A data set of TC or MI is made dark current and flat field correction (only for MI), cut the compression dummies off, and scaled to 512 pixels or less. Although SP data are constantly arranged top-to-bottom in time series, there are any cases they don't coincide with the direction of the thumbnail file. On the details, refer to Appendix1.

Thumbnail file is the reduced image of image data object included in L2A data set, and is the JPEG format image. And on the details of JPEG, refer to the reference books (2).

The specifications of thumbnail are described in the List 2.3-5.

List 2.3-5 Specifications of thumbnail file

Detector	Band number	Number of horizontal pixels	Number of vertical pixels	File size	Format
TC	N/A	512 or less	512 or less	100kb or less	8bitJPEG
MI-VIS	2				
MI-NIR	3				

When the size of image data object is smaller than the aforesaid size, the size of thumbnail file is the same as one of the image data object.

The band number is a default value.

2.3.3 SP PDS product file

RGC PDS product file of SP is the PDS file in attached format, and is composed of PDS label segment (header segment), ancillary and supplementary data object and spectrum data object.

PDS label is recorded in text format and ancillary and supplementary data object and image data object are recorded in binary format.

The composition of SP RGC PDS product file is shown in the Figure 2.3-3 and the format of SP RGC PDS product file is shown in the Figure 2.3-4.

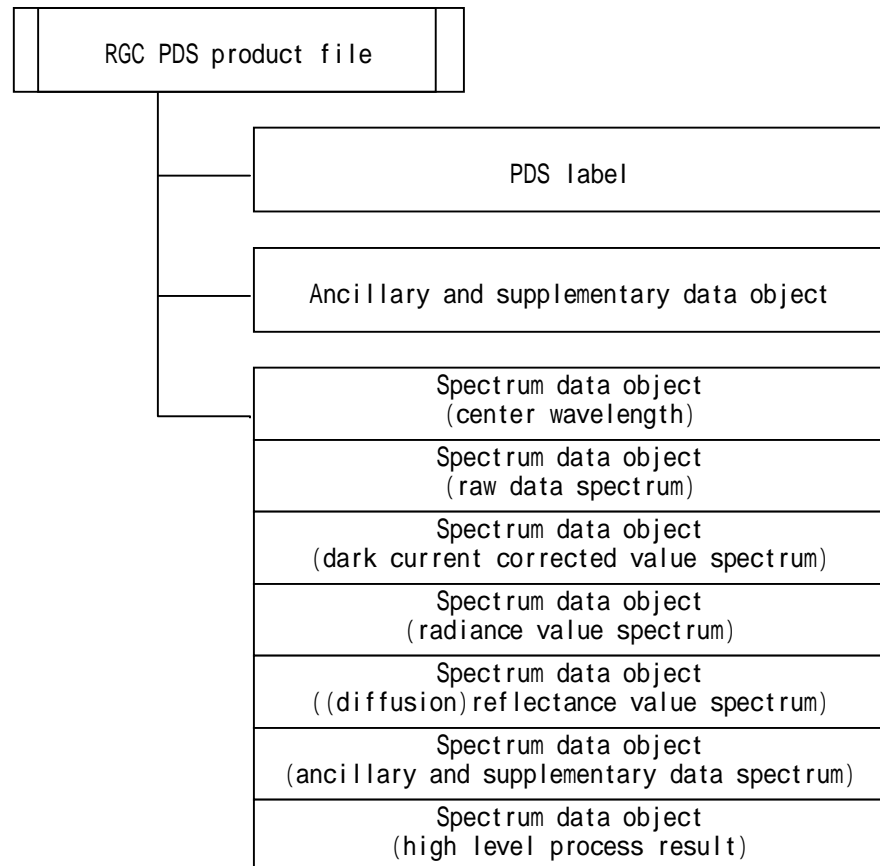

Figure 2.3-3 Composition of SP RGC PDS product file

PDS label	<ul style="list-style-type: none"> Prerequisite items for PDS header Version identification 		
	<ul style="list-style-type: none"> Area specifying object position Pointer to all objects 		
	Product information	<ul style="list-style-type: none"> File attribute e.g. file name, creating date, update date 	
		<ul style="list-style-type: none"> Product attribute e.g. software name used for creating product, producer identification, source data file name 	
		Scene attribute	<ul style="list-style-type: none"> Common to each instrument e.g. start time of the scene, stop time of the scene, observation mode name
			<ul style="list-style-type: none"> Variation by each instrument e.g. observation parameters, status
	<ul style="list-style-type: none"> Description area of ancillary and supplementary data object format Provision of format for describing ancillary and supplementary data object 		
	<ul style="list-style-type: none"> Description area of spectrum data object format(central wavelength) size, bit length 		
	<ul style="list-style-type: none"> Description area of spectrum data object format(raw data spectrum) 		
	<ul style="list-style-type: none"> Description area of spectrum data object format(dark current corrected value spectrum) 		
	<ul style="list-style-type: none"> Description area of spectrum data object format(radiance value spectrum) 		
	<ul style="list-style-type: none"> Description area of spectrum data object format((diffusion)reflectance value spectrum) 		
	<ul style="list-style-type: none"> Description area of spectrum data object format(ancillary and supplementary data spectrum) 		
	<ul style="list-style-type: none"> Description area of spectrum data object format(high level process result) 		
	<ul style="list-style-type: none"> Ancillary and supplementary data object Information per lines, ex. space craft clock count and temperature 		
<ul style="list-style-type: none"> Spectrum data object (central wavelength) e.g. size, bit length 			
<ul style="list-style-type: none"> Spectrum data object(raw data spectrum) 			
<ul style="list-style-type: none"> Spectrum data object format(dark current corrected value spectrum) 			
<ul style="list-style-type: none"> Spectrum data object(radiance value spectrum) 			
<ul style="list-style-type: none"> Spectrum data object(diffusion)reflectance value spectrum) 			
<ul style="list-style-type: none"> Spectrum data object(ancillary and supplementary data spectrum) 			
<ul style="list-style-type: none"> Spectrum data object(high level process result) 			

Figure 2.3-4 Format of SP RGC PDS product file

(1)PDS label

The details of PDS label of SP RGC PDS product file are shown in the list of List 2.3-6.

And on the case that the set value of PDS label is numeric value, if it does not fulfill maximum digit number, it is left-aligned by zero suppression in the absence of mentioning of particular reference.

List 2.3-6(1/5) Details of PDS label (SP)

Region	Item name	Description format	Item explanation	value	
Prerequisite items for PDS header	PDS version identification	PDS_VERSION_ID = "%s"	PDS version identification	"PDS3"	
	File record type	RECORD_TYPE = "%s"	File record type (prerequisite for L2DB)	"UNDEFINED"	
	File name (L2DB regulation)	FILE_NAME = "%s"	File name (prerequisite for L2DB)(uniquely decidable file name, involving extension(.img))	***.spc	
	Product identification (PDS practice)	PRODUCT_ID = "%s"	Product identification (uniquely decidable product identification, not involving extension)	***(no extension)	
Area specifying object position	Data file format identification	DATA_FORMAT = "%s"	Data file format identification (prerequisite for	"PDS"	
	Starting position of ancillary and supplementary data	*ANCILLARY_AND_SUPPLEMENT_DATA = %d <BYTES>	Starting position of ancillary and supplementary data object(in Byte)		
	Starting position of SP spectrum center wavelength object	*SP_SPECTRUM_WAV = %d <BYTES>	Starting position of SP spectrum center wavelength object(in Byte)		
	Starting position of SP spectrum raw data object	*SP_SPECTRUM_RAW = %d <BYTES>	Starting position of SP spectrum raw data object(in Byte)		
	Starting position of SP spectrum dark current estimate value object	*SP_SPECTRUM_DAR = %d <BYTES>	Starting position of SP spectrum dark current estimate value object(in Byte)		
	Starting position of SP spectrum radiance value object	*SP_SPECTRUM_RAD = %d <BYTES>	Starting position of SP spectrum radiance value object(in Byte)		
	Starting position of SP spectrum reflectance value object	*SP_SPECTRUM_REF = %d <BYTES>	Starting position of SP spectrum reflectance value object(in Byte)		
	Starting position of SP spectrum QA	*SP_SPECTRUM_QA = %d <BYTES>	Starting position of SP spectrum QA object(in		
	Starting position of L2D result array	*L2D_RESULT_ARRAY = %d <BYTES>	Starting position of L2D result array(in Byte)		
	Product information	File attribute	Software name	SOFTWARE_NAME = "%s"	Software name used for creating PDS product
Software version			SOFTWARE_VERSION = "%s"	Software version used for creating PDS product	n.n.n
Product information	Product attribute	Process version identification	PROCESS_VERSION_ID = "%s"	Process version identification (prerequisite for	"L2B", "L2C", "L2D"
		Product creation time	PRODUCT_CREATION_TIME = %s	Product creation time	YYYY-MM-DDThh:mm:ssZ
Product information	Product attribute	Program start time	PROGRAM_START_TIME = %s	Program start time	YYYY-MM-DDThh:mm:ssZ
		Producer identification	PRODUCER_ID = "%s"	Data producer identification	"LISM"
Product information	Product attribute	Product set identification	PRODUCT_SET_ID = "%s"	PDS product set types (prerequisite for L2DB) The name in product list should be used. As of data not registered in L2DB, it's be described	"SP_Level2B1", "SP_Level2B2", "SP_Level2C", "SP_Level2D", "Others"
		Product version identification	PRODUCT_VERSION_ID = "%s"	Product version registered in L2DB (prerequisite for L2DB)	"01" ~ "99"
Product information	Product attribute	Whether to be registered product in L2DB	REGISTERED_PRODUCT = "%s"	It's be set whether it was created as product for registration, regardless of success and failure of registration in L2DB	"Y" or "N"
		Source data file name	LEVEL2B1_FILE_NAME = "%s"	All source data file names used for creating this PDS product***.spc	L2B1:"N/A"
Product information	Product attribute	Source data file name	SOURCE_FILE_NAME = ("%s", "%s", "%s")	All source data file names used for creating this PDS product***.spc	
		SPICE metakernel file name	SPICE_METAKERNEL_FILE_NAME = "%s"	SPICE metakernel file names used for creating L1A PDS product	
Scene attribute	Common to each instrument	Mission name	MISSION_NAME = "%s"	Mission name	"SELENE"
		Spacecraft name	SPACECRAFT_NAME = "%s"	Spacecraft name	"SELENE-M"
Scene attribute	Common to each instrument	Data set identification	DATA_SET_ID = "%s"	Data set identification in which included this	
		Instrument name	INSTRUMENT_NAME = "%s"	Instrument name(full name) (prerequisite for L2DB)	"Spectral Profiler"
Scene attribute	Common to each instrument	Instrument identification	INSTRUMENT_ID = "%s"	Instrument identification	"SP"
		Mission phase name	MISSION_PHASE_NAME = "%s"	Mission phase name	(e.g. Nominal/Option)
Scene attribute	Common to each instrument	Revolution number	REVOLUTION_NUMBER = %d	Revolution number of this scene's starting position	L2B1: value of SP else: value of TC/MI
		Strip sequence number	STRIP_SEQUENCE_NUMBER = %d	Strip sequence number while in revolution	L2B1: value of SP else: value of TC/MI
Scene attribute	Common to each instrument	Scene sequence number	SCENE_SEQUENCE_NUMBER = %d	Scene sequence number while in strip	L2B1: value of SP else: value of TC/MI
		Revolution * strip * scene number	REV_STRIP_SCENE = {(%,d,%,d,%,d), (%,d,%,d,%,d), ...}	Number of revolution, strip, and scene including this scene	L2B2, L2C, L2D: "N/A"
Scene attribute	Common to each instrument	Observation target name	TARGET_NAME = "%s"	Observation target name of this strip	"MOON" (default)
		Observation mode identification	OBSERVATION_MODE_ID = "%s"	Observation mode identification (observation/dark/calibration and resolution) e.g. OBS-NORMAL	Observation: "OBS", "DARK", "LAMP" Resolution: "NORMAL", "HIGH", "BOTH"
Scene attribute	Common to each instrument	Sensor description	SENSOR_DESCRIPTION = "%s"	Sensor specification is set with character string	
		Sensor description 2	SENSOR_DESCRIPTION2 = "%s"	Alternative sensor description	
Scene attribute	Common to each instrument	Exposure mode identification	EXPOSURE_MODE_ID = "%s"	Exposure mode identification	"LONG", "SHORT"
		Short mode exposure duration	SHORT_EXPOSURE_DURATION = %,3f <msec>	Exposure duration on short mode	
Scene attribute	Common to each instrument	Long mode exposure duration	LONG_EXPOSURE_DURATION = %,3f <msec>	Exposure duration on long mode	
		Calibration mode identification	CALIBRATION_MODE_ID = "%s"	Calibration mode identification	
Scene attribute	Common to each instrument	Spacecraft clock start count (TI)	SPACECRAFT_CLOCK_START_COUNT = %,4f <sec>	Spacecraft clock start count on this scene (TI)	
		Spacecraft clock stop count (TI)	SPACECRAFT_CLOCK_STOP_COUNT = %,4f <sec>	Spacecraft clock stop count on this scene (TI)	
Scene attribute	Common to each instrument	Observation start time (UT)	START_TIME = %s	Observation start time on this scene (UT)	yyyy-mm-ddThh:mm:ss.ssssssZ
		Observation stop time (UT)	STOP_TIME = %s	Observation stop time on this scene (UT)	yyyy-mm-ddThh:mm:ss.ssssssZ
Scene attribute	Common to each instrument	Upper left latitude of this scene	UPPER_LEFT_LATITUDE = %,6f <deg>	Latitude of pixel on upper left corner of this scene (=latitude of pixel on upper right corner of this scene) Latitude of the pixel center on the first line snp.nnnnnn	[-90.000000, 90.000000]
		Upper left longitude of this scene	UPPER_LEFT_LONGITUDE = %,6f <deg>	Longitude of pixel on upper left corner of this scene (=longitude of pixel on upper right corner of this scene) Longitude of the pixel center on the first line nnn.nnnnnn	[0.000000, 360.000000]
Scene attribute	Common to each instrument	Upper right latitude of this scene	UPPER_RIGHT_LATITUDE = %,6f <deg>	Latitude of pixel on upper right corner of this scene (=latitude of pixel on upper left corner of this scene) Latitude of the pixel center on the first line nnn.nnnnnn	[-90.000000, 90.000000]
		Upper right longitude of this scene	UPPER_RIGHT_LONGITUDE = %,6f <deg>	Longitude of pixel on upper right corner of this scene (=longitude of pixel on upper left corner of this scene) Longitude of the pixel center on the first line nnn.nnnnnn	[0.000000, 360.000000]
Scene attribute	Common to each instrument	Lower left latitude of this scene	LOWER_LEFT_LATITUDE = %,6f <deg>	Latitude of pixel on lower left corner of this scene (=latitude of pixel on upper right corner of this scene) Latitude of the pixel center on the last line snp.nnnnnn	[-90.000000, 90.000000]
		Lower left longitude of this scene	LOWER_LEFT_LONGITUDE = %,6f <deg>	Longitude of pixel on lower left corner of this scene (=longitude of pixel on upper right corner of this scene) Longitude of the pixel center on the last line nnn.nnnnnn	[0.000000, 360.000000]
Scene attribute	Common to each instrument	Lower right latitude of this scene	LOWER_RIGHT_LATITUDE = %,6f <deg>	Latitude of pixel on lower right corner of this scene (=latitude of pixel on upper left corner of this scene) Latitude of the pixel center on the last line snp.nnnnnn	[-90.000000, 90.000000]
		Lower right longitude of this scene	LOWER_RIGHT_LONGITUDE = %,6f <deg>	Longitude of pixel on lower right corner of this scene (=longitude of pixel on upper left corner of this scene) Longitude of the pixel center on the last line nnn.nnnnnn	[0.000000, 360.000000]
Scene attribute	Common to each instrument	Location flag	LOCATION_FLAG = "%s"	Information of spacecraft location	L2B1: value of SP else: value of TC/MI A: ascending D: descending N: involving north pole S: involving south pole W: involving both poles Explanation on criteria for determining It is determined on the basis of the satellite argument of latitude, which shall be the angle toward lunar center, between the ascending node and the current satellite position, and zero degree as passing through the ascending node) at the both observation times of the first line and the last line of the scene. A: Both are in the ascending side (>270 degrees or [0 degree, 90 degrees]) and do not exceed half of the rotation period. D: Both are in the descending side (90 degrees, 270 degrees) and do not exceed half of the rotation period. N: Between the two, 90 degrees is included and 270 degrees is not. S: Between the two, 270 degrees is included and 90 degrees is not. W: Between the two, 90 degrees and 270 degrees are both included.
		Roll cant	ROLL_CANT = "%s"	Discrimination of nadir looking or roll cant observation	YES: roll cant NO: nadir looking
Scene attribute	Common to each instrument	Distance between moon and sun	MOON_SUN_DISTANCE = %d <km>	Distance between moon and sun	
		VIS focal plane temperature	VIS_FOCAL_PLANE_TEMPERATURE = %,2f <degC>	VIS focal plane temperature at observation on the first line	
Scene attribute	Common to each instrument	NIR1 focal plane temperature	NIR1_FOCAL_PLANE_TEMPERATURE = %,2f <degC>	NIR1 focal plane temperature at observation on the first line	
		NIR2 focal plane temperature	NIR2_FOCAL_PLANE_TEMPERATURE = %,2f <degC>	NIR2 focal plane temperature at observation on the first line	
Scene attribute	Common to each instrument	Satellite moving direction	SATELLITE_MOVING_DIRECTION = "%s"	Moving direction of satellite	L2B1: value of SP else: value of TC/MI "+1": lead of +x plane "-1": lead of -x plane
		Radius of lunar shape (a axis)	A_AXIS_RADIUS = %,3f <km>	Lunar radius in a axis. nnnn.nnn (indicate down to meter order)	
Scene attribute	Common to each instrument	Radius of lunar shape (b axis)	B_AXIS_RADIUS = %,3f <km>	Lunar radius in b axis. nnnn.nnn (indicate down to meter order)	
		Radius of lunar shape (c axis)	C_AXIS_RADIUS = %,3f <km>	Lunar radius in c axis. nnnn.nnn (indicate down to meter order)	

List 2.3-6(2/5) Details of PDS label (SP)

Region	Item name	Description format	Item explanation	value	
Product information	Scene attribute	Variation by each instrument	Approximate spacecraft altitude	SPACECRAFT_ALTITUDE = %.3f <km>	Spacecraft altitude of the first line("distance between spacecraft and lunar gravitational center" minus average lunar radius)
			Spacecraft ground speed	SPACECRAFT_GROUND_SPEED = %.3f <km/sec>	Spacecraft ground speed of the first line
			VIS band number	VIS_BAND_NUMBER = %d	VIS band number
			VIS spectral coverage	VIS_SPECTRAL_COVERAGE = (%.1f,%.1f) <nm>	Shortest wavelengths and longest wavelengths of VIS(nominal value)
			VIS band width	VIS_BAND_WIDTH = %.1f <nm>	Band width of VIS(full-width at half-maximum, nominal value)
			NIR1 band number	N1_BAND_NUMBER = %d	NIR1 band number
			NIR1 spectral coverage	N1_SPECTRAL_COVERAGE = (%.1f,%.1f) <nm>	Shortest wavelengths and longest wavelengths of NIR1(nominal value)
			NIR1 band width	N1_BAND_WIDTH = %.1f <nm>	Band width of NIR1(full-width at half-maximum, nominal value)
			NIR2 band number	N2_BAND_NUMBER = %d	NIR2 band number
			NIR2 spectral coverage	N2_SPECTRAL_COVERAGE = (%.1f,%.1f) <nm>	Shortest wavelengths and longest wavelengths of NIR2(nominal value)
			NIR2 band width	N2_BAND_WIDTH = %.1f <nm>	Band width of NIR2(full-width at half-maximum, nominal value)
			Process parameter file name	PROCESS_PARAMETER_FILE_NAME = "%s"	Parameter file name used for each process version
			Longitude of daytime equator crossing	DAYTIME_EQUATOR_CROSSING_LON = %s	Longitude of the point with minimum latitude on dayside: 6.2f <deg> If only nightside: "NIGHT"
		TC/MI image acquired at the same time of SP observation	Imager information	IMAGER = "%s"	Band identification of TC/MI image acquired at the same time of SP observation
			Data set name of TC/MI image acquired at the same time of SP observation	TM_DATA_SET_NAME = "%s"	Data set name of TC/MI image acquired at the same time of SP observation
			Corrected start time of TC/MI image acquired at the same time of SP observation	TM_CORRECTED_START_TIME = %s	Corrected start time (UT) (six decimal places)
			Corrected stop time of TC/MI image acquired at the same time of SP observation	TM_CORRECTED_STOP_TIME = %s	Corrected stop time(UT) (six decimal places)
			Corrected sampling interval of TC/MI image acquired at the same time of SP observation	TM_CORRECTED_SAMPLING_INTERVAL = %.6f <msec>	Corrected sampling interval with dividing the corrected interval time between first line and last line of strip into the number of lines.
			Number of lines of TC/MI image acquired at the same time of SP observation	TM_LINES = %d	Number of pixels along the vertical axis of this scene(direction of along track)
			Number of line's samples of TC/MI image acquired at the same time of SP observation	TM_LINE_SAMPLES = %d	Number of pixels along the horizontal axis of this scene(direction of cross track)
			First pixel number of TC/MI image acquired at the same time of SP observation	TM_FIRST_PIXEL_NUMBER = %d	First detector element number(defined value)
			Last pixel number of TC/MI image acquired at the same time of SP observation	TM_LAST_PIXEL_NUMBER = %d	Last detector element number(defined value)
			Upper left latitude on the scene of TC/MI image acquired at the same time of SP observation	TM_UPPER_LEFT_LATITUDE = %.6f <deg>	Latitude of the pixel center on the first column and the first line snn.nnnnnn
			Upper left longitude on the scene of TC/MI image acquired at the same time of SP observation	TM_UPPER_LEFT_LONGITUDE = %.6f <deg>	Longitude of the pixel center on the first column and the first line nnn.nnnnnn
			Upper right latitude on the scene of TC/MI image acquired at the same time of SP observation	TM_UPPER_RIGHT_LATITUDE = %.6f <deg>	Latitude of the pixel center on the last column and the first line snn.nnnnnn
			Upper right longitude on the scene of TC/MI image acquired at the same time of SP observation	TM_UPPER_RIGHT_LONGITUDE = %.6f <deg>	Longitude of the pixel center on the last column and the first line nnn.nnnnnn
			Lower left latitude on the scene of TC/MI image acquired at the same time of SP observation	TM_LOWER_LEFT_LATITUDE = %.6f <deg>	Latitude of the pixel center on the first column and the last line snn.nnnnnn
			Lower left longitude on the scene of TC/MI image acquired at the same time of SP observation	TM_LOWER_LEFT_LONGITUDE = %.6f <deg>	Longitude of the pixel center on the first column and the last line nnn.nnnnnn
			Lower right latitude on the scene of TC/MI image acquired at the same time of SP observation	TM_LOWER_RIGHT_LATITUDE = %.6f <deg>	Latitude of the pixel center on the last column and the last line snn.nnnnnn
			Lower right longitude on the scene of TC/MI image acquired at the same time of SP observation	TM_LOWER_RIGHT_LONGITUDE = %.6f <deg>	Longitude of the pixel center on the last column and the last line nnn.nnnnnn
			Saturated pixel percentage, whose value is more than or equal to D3, of TC/MI image acquired at the same time of SP observation	TM_SATURATED_PIXEL_PERCENTAGE = %d	Percentage of saturated pixels(omit decimal fractions)
			Saturated pixel percentage, whose value is less than or equal to D4, of TC/MI image acquired at the same time of SP observation	TM_DEAD_PIXEL_PERCENTAGE = %d	Percentage of dead pixels(omit decimal fractions)
			Saturated pixel percentage, whose value is between D5 and D6, of TC/MI image acquired at the same time of SP observation	TM_SHADOWED_AREA_PIXEL_PERCENTAGE = %d	Percentage of shadowed area pixels(omit decimal fractions)
			High resolution observation point number	HIGH_SP_POINT_NUM = %d	
			Normal resolution observation point number	NORMAL_SP_POINT_NUM = %d	
			Upper margin observation point number	UPPER_MARGIN_POINT_NUM = %d	Observation points number longly cut off above TC/MI image acquired at the same time of SP
			Lower margin observation point number	LOWER_MARGIN_POINT_NUM = %d	Observation points number longly cut off below TC/MI image acquired at the same time of SP
			Calibration lamp information	CAL_LAMP_INFO = ((*%s*%s*%s),(*%s*%s*%s),...)	Type of calibration lamp, set of the time to light on and off.
			Matching accuracy information	MATCHING_ACCURACY_INFO= "%s"	Setting "1" if the following conditions are fulfilled, or "0" if not, starting from the left. 1: Maximum of correlation coefficient is more than or equal to threshold. 2: Average of correlation coefficient is less than or equal to threshold. 3: Percentage of correlation coefficient being more than or equal to the setting value is less than or equal to threshold. 4: Number of peaks having correlation coefficient being more than or equal to setting value is less than or equal to threshold.

List 2.3-6(3/5) Details of PDS label (SP)

Region	Item name	Description format	Item explanation	value	
Description area of ancillary and supplementary data object format	OBJECT = ANCILLARY_AND_SUPPLEMENT_DATA				
	format	INTERCHANGE_FORMAT = %s		"BINARY"	
	Number of rows	ROWS = %d	Number of rows in this scene		
	Number of columns	COLUMNS = %d	Number of columns in the list	43	
	Row bytes	ROW_BYTES = %d	Bytes in a row	bef L2B2:158, aft L2C:166	
	Line information	Clock count of spacecraft(T1)	OBJECT = COLUMN NAME = "SPACECRAFT_CLOCK_COUNT" DATA_TYPE = "IEEE_REAL" UNIT = "sec" START_BYTE = 1 BYTES = 8 END_OBJECT = COLUMN	Recording format of clock count of spacecraft(T1)	
		VIS focal plane temperature	OBJECT = COLUMN NAME = "VIS_FOCAL_PLANE_TEMPERATURE" DATA_TYPE = "IEEE_REAL" UNIT = "degC" START_BYTE = 9 BYTES = 4 END_OBJECT = COLUMN	Recording format of VIS focal plane temperature	
		NIR1 focal plane temperature	OBJECT = COLUMN NAME = "NIR1_FOCAL_PLANE_TEMPERATURE" DATA_TYPE = "IEEE_REAL" UNIT = "degC" START_BYTE = 13 BYTES = 4 END_OBJECT = COLUMN	Recording format of NIR1 focal plane temperature	
		NIR2 focal plane temperature	OBJECT = COLUMN NAME = "NIR2_FOCAL_PLANE_TEMPERATURE" DATA_TYPE = "IEEE_REAL" UNIT = "K" START_BYTE = 17 BYTES = 4 END_OBJECT = COLUMN	Recording format of NIR2 focal plane temperature	
		Spectrometer temperature 1	OBJECT = COLUMN NAME = "SPECTROMETER_TEMPERATURE_1" DATA_TYPE = "IEEE_REAL" UNIT = "degC" START_BYTE = 21 BYTES = 4 END_OBJECT = COLUMN	Recording format of spectrometer temperature 1	
		Spectrometer temperature 2	OBJECT = COLUMN NAME = "SPECTROMETER_TEMPERATURE_2" DATA_TYPE = "IEEE_REAL" UNIT = "degC" START_BYTE = 25 BYTES = 4 END_OBJECT = COLUMN	Recording format of spectrometer temperature 2	
		Spectrometer temperature 3	OBJECT = COLUMN NAME = "SPECTROMETER_TEMPERATURE_3" DATA_TYPE = "IEEE_REAL" UNIT = "degC" START_BYTE = 29 BYTES = 4 END_OBJECT = COLUMN	Recording format of spectrometer temperature 3	
		Spectrometer temperature 4	OBJECT = COLUMN NAME = "SPECTROMETER_TEMPERATURE_4" DATA_TYPE = "IEEE_REAL" UNIT = "degC" START_BYTE = 33 BYTES = 4 END_OBJECT = COLUMN	Recording format of spectrometer temperature 4	
		Halogen bulb radiance	OBJECT = COLUMN NAME = "HALOGEN_BULB_RADIANCE" DATA_TYPE = "IEEE_REAL" UNIT = "V" START_BYTE = 37 BYTES = 4 END_OBJECT = COLUMN	Recording format of halogen bulb radiance	
		Halogen bulb voltage 1	OBJECT = COLUMN NAME = "HALOGEN_BULB_VOLTAGE1" DATA_TYPE = "IEEE_REAL" UNIT = "V" START_BYTE = 41 BYTES = 4 END_OBJECT = COLUMN	Recording format of halogen bulb voltage 1	
		Halogen bulb voltage 2	OBJECT = COLUMN NAME = "HALOGEN_BULB_VOLTAGE2" DATA_TYPE = "IEEE_REAL" UNIT = "V" START_BYTE = 45 BYTES = 4 END_OBJECT = COLUMN	Recording format of halogen bulb voltage 2	
		Halogen bulb temperature 1	OBJECT = COLUMN NAME = "HALOGEN_BULB_TEMPERATURE1" DATA_TYPE = "IEEE_REAL" UNIT = "degC" START_BYTE = 49 BYTES = 4 END_OBJECT = COLUMN	Recording format of halogen bulb temperature 1	
		Halogen bulb temperature 2	OBJECT = COLUMN NAME = "HALOGEN_BULB_TEMPERATURE2" DATA_TYPE = "IEEE_REAL" UNIT = "degC" START_BYTE = 53 BYTES = 4 END_OBJECT = COLUMN	Recording format of halogen bulb temperature 2	
		Spacecraft altitude	OBJECT = COLUMN NAME = "SPACECRAFT_ALTITUDE" DATA_TYPE = "IEEE_REAL" UNIT = "km" START_BYTE = 57 BYTES = 4 END_OBJECT = COLUMN	Recording format of spacecraft altitude	
		Spacecraft ground speed	OBJECT = COLUMN NAME = "SPACECRAFT_GROUND_SPEED" DATA_TYPE = "IEEE_REAL" UNIT = "km/sec" START_BYTE = 61 BYTES = 4 END_OBJECT = COLUMN	Recording format of spacecraft ground speed	
	Sub-spacecraft latitude	OBJECT = COLUMN NAME = "SUB_SPACECRAFT_LATITUDE" DATA_TYPE = "IEEE_REAL" UNIT = "deg" START_BYTE = 65 BYTES = 8 END_OBJECT = COLUMN	Recording format of sub-spacecraft latitude		
	Sub-spacecraft longitude	OBJECT = COLUMN NAME = "SUB_SPACECRAFT_LONGITUDE" DATA_TYPE = "IEEE_REAL" UNIT = "deg" START_BYTE = 73 BYTES = 8 END_OBJECT = COLUMN	Recording format of sub-spacecraft longitude		

B

List 2.3-6(4/5) Details of PDS label (SP)

Region	Item name	Description format	Item explanation	value
Description area of ancillary and supplementary data object format	Line information			
	SP observation point latitude	OBJECT = COLUMN NAME = "CENTER_LATITUDE" DATA_TYPE = "IEEE_REAL" UNIT = "deg" START_BYTE = 81 BYTES = 8 END_OBJECT = COLUMN	Recording format of SP observation point latitude	
	SP observation point longitude	OBJECT = COLUMN NAME = "CENTER_LONGITUDE" DATA_TYPE = "IEEE_REAL" UNIT = "deg" START_BYTE = 89 BYTES = 8 END_OBJECT = COLUMN	Recording format of SP observation point longitude	
	Geometric condition of sensor observation(emission angle)	OBJECT = COLUMN NAME = "EMISSION_ANGLE" DATA_TYPE = "IEEE_REAL" UNIT = "deg" START_BYTE = 97 BYTES = 4 END_OBJECT = COLUMN	Recording format of geometric condition of sensor observation(emission angle)	
	Geometric condition of sensor observation(azimuth angle)	OBJECT = COLUMN NAME = "SPACECRAFT_AZIMUTH" DATA_TYPE = "IEEE_REAL" UNIT = "deg" START_BYTE = 101 BYTES = 4 END_OBJECT = COLUMN	Recording format of geometric condition of sensor observation(azimuth angle)	
	Geometric condition of solar radiation(incidence angle)	OBJECT = COLUMN NAME = "INCIDENCE_ANGLE" DATA_TYPE = "IEEE_REAL" UNIT = "deg" START_BYTE = 105 BYTES = 4 END_OBJECT = COLUMN	Recording format of geometric condition of solar radiation(incidence angle)	
	Geometric condition of solar radiation(azimuth angle)	OBJECT = COLUMN NAME = "SOLAR_AZIMUTH_ANGLE" DATA_TYPE = "IEEE_REAL" UNIT = "deg" START_BYTE = 109 BYTES = 4 END_OBJECT = COLUMN	Recording format of geometric condition of solar radiation(azimuth angle)	
	Phase angle	OBJECT = COLUMN NAME = "PHASE_ANGLE" DATA_TYPE = "IEEE_REAL" UNIT = "deg" START_BYTE = 113 BYTES = 4 END_OBJECT = COLUMN	Recording format of phase angle	
	Temperature of the point specifying SP temperature	OBJECT = COLUMN NAME = "SP_TEMPERATURE" DATA_TYPE = "IEEE_REAL" UNIT = "deg" START_BYTE = 117 BYTES = 4 END_OBJECT = COLUMN	Recording format of temperature of the point specifying SP temperature	
	SP peltier hot side temperature	OBJECT = COLUMN NAME = "SP_PELTIER_HOT_TEMPERATURE" DATA_TYPE = "IEEE_REAL" UNIT = "degC" START_BYTE = 121 BYTES = 4 END_OBJECT = COLUMN	Recording format of SP peltier hot side temperature	
	SP2 radiator temperature	OBJECT = COLUMN NAME = "SP_N2_RADIATOR_TEMPERATURE" DATA_TYPE = "IEEE_REAL" UNIT = "degC" START_BYTE = 125 BYTES = 4 END_OBJECT = COLUMN	Recording format of SP2 radiator temperature	
	Temperature of SP calibration optics(VIS)	OBJECT = COLUMN NAME = "SP_CAL_VIS_TEMPERATURE" DATA_TYPE = "IEEE_REAL" UNIT = "degC" START_BYTE = 129 BYTES = 4 END_OBJECT = COLUMN	Recording format of temperature of SP calibration optics(VIS)	
	Temperature of SP calibration optics(NIR)	OBJECT = COLUMN NAME = "SP_CAL_NIR_TEMPERATURE" DATA_TYPE = "IEEE_REAL" UNIT = "degC" START_BYTE = 133 BYTES = 4 END_OBJECT = COLUMN	Recording format of temperature of SP calibration optics(NIR)	
	Temperature of the point specifying DPU temperature	OBJECT = COLUMN NAME = "DPU_TEMPERATURE" DATA_TYPE = "IEEE_REAL" UNIT = "degC" START_BYTE = 137 BYTES = 4 END_OBJECT = COLUMN	Recording format of temperature of the point specifying DPU temperature	
	SP power voltage plus 5V	OBJECT = COLUMN NAME = "SP_POWER_P5V" DATA_TYPE = "IEEE_REAL" UNIT = "V" START_BYTE = 141 BYTES = 4 END_OBJECT = COLUMN	Recording format of SP power voltage plus 5V	
	SP power voltage minus 15V	OBJECT = COLUMN NAME = "SP_POWER_M15V" DATA_TYPE = "IEEE_REAL" UNIT = "V" START_BYTE = 145 BYTES = 4 END_OBJECT = COLUMN	Recording format of SP power voltage minus 15V	
	SP power voltage plus 15V	OBJECT = COLUMN NAME = "SP_POWER_P15V" DATA_TYPE = "IEEE_REAL" UNIT = "V" START_BYTE = 149 BYTES = 4 END_OBJECT = COLUMN	Recording format of SP power voltage plus 15V	
	Calibration mode identification	OBJECT = COLUMN NAME = "CALIBRATION" DATA_TYPE = "MSB_INTEGER" UNIT = "N/A" START_BYTE = 153 BYTES = 1 END_OBJECT = COLUMN	Recording format of calibration mode identification	
	SP peltier ON/OFF	OBJECT = COLUMN NAME = "SP_PELTIER" DATA_TYPE = "MSB_INTEGER" UNIT = "N/A" START_BYTE = 154 BYTES = 1 END_OBJECT = COLUMN	Recording format of SP peltier ON/OFF	

List 2.3-6(5/5) Details of PDS label (SP)

Region	Item name	Description format	Item explanation	value	
Description area of ancillary and supplementary data object format	Line information	TC/MI status	OBJECT = COLUMN NAME = "TC_MI_STATUS" DATA_TYPE = "MSB_INTEGER" UNIT = "N/A" START_BYTE = 155 BYTES = 1 END_OBJECT = COLUMN	Recording format of TC/MI status	
		Clock count error flag	OBJECT = COLUMN NAME = "CLOCK_COUNT_ERR_FLAG" DATA_TYPE = "MSB_INTEGER" UNIT = "N/A" START_BYTE = 156 BYTES = 1 END_OBJECT = COLUMN	Recording format of clock count error flag	
		Spatial resolution flag	OBJECT = COLUMN NAME = "SPATIAL_RESOLUTION_FLAG" DATA_TYPE = "MSB_UNSIGNED_INTEGER" UNIT = "N/A" START_BYTE = 157 BYTES = 1 END_OBJECT = COLUMN	Observation mode A(65) : exposure duration S, resolution N B(66) : exposure duration L, resolution N C(67) : exposure duration S, resolution H D(68) : exposure duration L, resolution H	A,B,C,D
		Geometric information recalculation flag	OBJECT = COLUMN NAME = "GEOMETRIC_INFO_RECAL_FLAG" DATA_TYPE = "MSB_UNSIGNED_INTEGER" UNIT = "N/A" START_BYTE = 158 BYTES = 1 END_OBJECT = COLUMN	A(65) : Without recalculating (taking over from L2A) B(66) : Update by the newest kernel file C(67) : Update by the matching result with TC/MI image acquired at the same time of SP observation	A,B,C
		Position of observation point on the support image (LINE)	OBJECT = COLUMN NAME = "SUPPORT_IMAGE_LINE_POSITION" DATA_TYPE = "MSB_UNSIGNED_INTEGER" UNIT = "N/A" START_BYTE = 159 BYTES = 2 or 0 END_OBJECT = COLUMN		L2B1, L2B2:BYTES=0 L2C, L2D :BYTES=2
		Position of observation point on the support image (COLUMN)	OBJECT = COLUMN NAME = "SUPPORT_IMAGE_COLUMN_POSITION" DATA_TYPE = "MSB_UNSIGNED_INTEGER" UNIT = "N/A" START_BYTE = 161 BYTES = 2 or 0 END_OBJECT = COLUMN		L2B1, L2B2:START_BYTE=159 L2C, L2D :START_BYTE=161 L2B1, L2B2:BYTES=0 L2C, L2D :BYTES=2
		Position of observation point on the thumbnail image (LINE)	OBJECT = COLUMN NAME = "THUMBNAI_LLINE_POSITION" DATA_TYPE = "MSB_UNSIGNED_INTEGER" UNIT = "N/A" START_BYTE = 163 BYTES = 2 or 0 END_OBJECT = COLUMN		L2B1, L2B2:START_BYTE=159 L2C, L2D :START_BYTE=163 L2B1, L2B2:BYTES=0 L2C, L2D :BYTES=2
		Position of observation point on the thumbnail image (COLUMN)	OBJECT = COLUMN NAME = "THUMBNAI_COLUMN_POSITION" DATA_TYPE = "MSB_UNSIGNED_INTEGER" UNIT = "N/A" START_BYTE = 165 BYTES = 2 or 0 END_OBJECT = COLUMN		L2B1, L2B2:START_BYTE=159 L2C, L2D :START_BYTE=165 L2B1, L2B2:BYTES=0 L2C, L2D :BYTES=2
		END_OBJECT = ANCILLARY_AND_SUPPLEMENT_DATA			
Description area of image data object	Center wavelength	Number of lines of this scene Number of line's samples of this scene Sample type Sample bits Image value type Unit Scaling factor Offset	OBJECT = SP_SPECTRUM_WAV LINES = %d LINE_SAMPLES = %d SAMPLE_TYPE = "%s" SAMPLE_BITS = %d IMAGE_VALUE_TYPE = "%s" UNIT = "%s" SCALING_FACTOR = %f OFFSET = %f END_OBJECT	Number of pixels along the vertical axis of this scene(direction of along track) Number of pixels along the horizontal axis of this scene(direction of cross track) Sample type Sample bit length Image value type Sample unit Conversion coefficient Offset value	1 296 "MSB_UNSIGNED_INTEGER" 16 "WAVELENGTH" "nm"
	Raw data spectrum	Number of lines of this scene Number of line's samples of this scene Sample type Sample bits Image value type Unit Scaling factor Offset	OBJECT = SP_SPECTRUM_RAW LINES = %d LINE_SAMPLES = %d SAMPLE_TYPE = "%s" SAMPLE_BITS = %d IMAGE_VALUE_TYPE = "%s" UNIT = "%s" SCALING_FACTOR = %f OFFSET = %f END_OBJECT	Number of pixels along the vertical axis of this scene(direction of along track) Number of pixels along the horizontal axis of this scene(direction of cross track) Sample type Sample bit length Image value type Sample unit Conversion coefficient Offset value	296 "MSB_UNSIGNED_INTEGER" 16 "RAW_DN" "ND"
	Dark current corrected value spectrum	Number of lines of this scene Number of line's samples of this scene Sample type Sample bits Image value type Unit Scaling factor Offset	OBJECT = SP_SPECTRUM_DAR LINES = %d LINE_SAMPLES = %d SAMPLE_TYPE = "%s" SAMPLE_BITS = %d IMAGE_VALUE_TYPE = "%s" UNIT = "%s" SCALING_FACTOR = %f OFFSET = %f END_OBJECT	Number of pixels along the vertical axis of this scene(direction of along track) Number of pixels along the horizontal axis of this scene(direction of cross track) Sample type Sample bit length Image value type Sample unit Conversion coefficient Offset value	296 "MSB_UNSIGNED_INTEGER" 16 "DARK" "ND"
	Radiance value spectrum	Number of lines of this scene Number of line's samples of this scene Sample type Sample bits Image value type Unit Scaling factor Offset	OBJECT = SP_SPECTRUM_RAD LINES = %d LINE_SAMPLES = %d SAMPLE_TYPE = "%s" SAMPLE_BITS = %d IMAGE_VALUE_TYPE = "%s" UNIT = "%s" SCALING_FACTOR = %f OFFSET = %f END_OBJECT	Number of pixels along the vertical axis of this scene(direction of along track) Number of pixels along the horizontal axis of this scene(direction of cross track) Sample type Sample bit length Image value type Sample unit Conversion coefficient Offset value	296 "MSB_UNSIGNED_INTEGER" 16 "RADIANCE" "W/m**2/micron/sr"
	(Diffusion) reflectance value spectrum	Number of lines of this scene Number of line's samples of this scene Sample type Sample bits Image value type Scaling factor Offset	OBJECT = SP_SPECTRUM_REF LINES = %d LINE_SAMPLES = %d SAMPLE_TYPE = "%s" SAMPLE_BITS = %d IMAGE_VALUE_TYPE = "%s" UNIT = "%s" SCALING_FACTOR = %f OFFSET = %f END_OBJECT	Number of pixels along the vertical axis of this scene(direction of along track) Number of pixels along the horizontal axis of this scene(direction of cross track) Sample type Sample bit length Image value type Sample unit Conversion coefficient Offset value	296 "MSB_UNSIGNED_INTEGER" 16 "REFLECTANCE" "ND"
	Ancillary supplementary and data spectrum	Number of lines of this scene Number of line's samples of this scene Sample type Sample bits Image value type Unit Scaling factor Offset	OBJECT = SP_SPECTRUM_QA LINES = %d LINE_SAMPLES = %d SAMPLE_TYPE = "%s" SAMPLE_BITS = %d IMAGE_VALUE_TYPE = "%s" UNIT = "%s" SCALING_FACTOR = %f OFFSET = %f END_OBJECT	Number of pixels along the vertical axis of this scene(direction of along track) Number of pixels along the horizontal axis of this scene(direction of cross track) Sample type Sample bit length Image value type Sample unit Conversion coefficient Offset value	296 "MSB_UNSIGNED_INTEGER" 16 "QUALITY" "N/A"
	High level process result	Number of lines of this scene Number of line's samples of this scene Sample type Sample bits Image value type Unit Scaling factor Offset	OBJECT = L2D_RESULT_ARRAY LINES = %d LINE_SAMPLES = %d SAMPLE_TYPE = "%s" SAMPLE_BITS = %d IMAGE_VALUE_TYPE = "%s" UNIT = "%s" SCALING_FACTOR = %f OFFSET = %f END_OBJECT	Number of pixels along the vertical axis of this scene(direction of along track) Number of pixels along the horizontal axis of this scene(direction of cross track) Sample type Sample bit length Image value type Sample unit Conversion coefficient Offset value	L2B1, L2B2, L2C: LINES = 0 LINE_SAMPLES = 0 SAMPLE_TYPE = "N/A" SAMPLE_BITS = 0 IMAGE_VALUE_TYPE= "N/A" UNIT = "N/A" SCALING_FACTOR = "N/A" OFFSET = "N/A" L2D: LINES = n LINE_SAMPLES = 128 SAMPLE_TYPE = "IEEE_REAL" SAMPLE_BITS = 32 IMAGE_VALUE_TYPE= "SURFACE_VARIABLES" UNIT = "N/A" SCALING_FACTOR = "N/A" OFFSET = "N/A"
			END		

(2) Ancillary and supplementary data object

The details of SP ancillary and supplementary data object are shown in the list of List 2.3-7 and byte orders in the List 2.3-7 are all big endian.

List 2.3-7(1/4) Details of ancillary and supplementary data object

Item name	Type	Byte	Unit	Item explanation
Clock count of spacecraft	Real number	8	s	Clock count of spacecraft
VIS focal plane temperature	Real number	4	degrees C	VIS focal plane temperature after converting engineering value
NIR1 focal plane temperature	Real number	4	degrees C	NIR1 focal plane temperature after converting engineering value
NIR2 focal plane temperature	Real number	4	K	NIR2 focal plane temperature after converting engineering value
Spectrometer temperature 1	Real number	4	degrees C	Spectrometer temperature 1
Spectrometer temperature 2	Real number	4	degrees C	Spectrometer temperature 2
Spectrometer temperature 3	Real number	4	degrees C	Spectrometer temperature 3
Spectrometer temperature 4	Real number	4	degrees C	Spectrometer temperature 4
Halogen bulb radiance	Real number	4	V	Halogen bulb radiance
Halogen bulb voltage 1	Real number	4	V	Halogen bulb voltage 1 after converting engineering value
Halogen bulb voltage 2	Real number	4	V	Halogen bulb voltage 2 after converting engineering value
Halogen bulb temperature 1	Real number	4	degrees C	Halogen bulb temperature 1 after converting engineering value
Halogen bulb temperature 2	Real number	4	degrees C	Halogen bulb temperature 2 after converting engineering value
Spacecraft altitude	Real number	4	km	Distance between spacecraft and moon
Spacecraft ground speed	Real number	4	km/s	Spacecraft ground speed
Sub-spacecraft latitude	Real number	8	degree	Sub-spacecraft latitude between -90 and 90

List 2.3-7(2/4) Details of ancillary and supplementary data object

Item name	Type	Byte	Unit	Item explanation
Sub-spacecraft longitude	Real number	8	degree	Sub-spacecraft longitude
SP observation point latitude	Real number	8	degree	Latitude of observation point
SP observation point longitude	Real number	8	degree	Longitude of observation point
Geometric condition of sensor observation(emission angle)	Real number	4	degree	Emission angle viewed from observation point
Geometric condition of sensor observation(azimuth angle)	Real number	4	degree	Azimuth angle viewed from observation point
Geometric condition of solar radiation(incidence angle)	Real number	4	degree	Incidence angle viewed from observation point
Geometric condition of solar radiation(azimuth angle)	Real number	4	degree	Azimuth angle viewed from observation point
Phase angle	Real number	4	degree	Phase angle at the observation point between a vector to the sun and a vector to the spacecraft
Temperature of the point specifying SP temperature	Real number	4	degrees C	Temperature of the point specifying SP temperature after converting engineering value
SP peltier hot side temperature	Real number	4	degrees C	SP peltier hot side temperature after converting engineering value
SPN2 radiator temperature	Real number	4	degrees C	SP2 radiator temperature after converting engineering value

List 2.3-7(3/4) Details of ancillary and supplementary data object

Item name	Type	Byte	Unit	Item explanation
Temperature of SP calibration optics(VIS)	Real number	4	degrees C	Temperature of SP calibration optics(VIS) after converting engineering value
Temperature of SP calibration optics(NIR)	Real number	4	degrees C	Temperature of SP calibration optics(NIR) after converting engineering value
Temperature of the point specifying DPU temperature	Real number	4	degrees C	Temperature of the point specifying DPU temperature after converting engineering value
SP power voltage plus 5V	Real number	4	V	SP power voltage plus 5V after converting engineering value
SP power voltage minus 15V	Real number	4	V	SP power voltage minus 15V after converting engineering value
SP power voltage plus 15V	Real number	4	V	SP power voltage plus 15V after converting engineering value
Calibration mode identification	Integral number	1	-	0:without calibration 1:geometric calibration 2:wavelength calibration 3:geometric and wavelength calibration
SP peltier ON/OFF	Integral number	1	-	0:OFF 1:ON
TC/MI status	Integral number	1	-	0:OFF 1:TC ON 2:MI ON
Clock count error flag	Integral number	1	-	0: without interpolation 1: interpolation of bit garbled time
Spatial resolution flag	Integral number without sign	1	-	A(65):exposure duration S , resolution N B(66):exposure duration L , resolution N C(67):exposure duration S , resolution H D(68):exposure duration L , resolution H

List 2.3-7(4/4) Details of ancillary and supplementary data object

Item name	Type	Byte	Unit	Item explanation
Geometric information recalculation flag	Integral number without sign	1	-	A(65): Without recalculation B(66): Update by the newest kernel file C(67): Update by the matching result with TC/MI image acquired at the same time of SP observation
Support image line position of observation point (LINE)	Integral number without sign	2(0)	-	Position of observation point on support image of TC /MI image acquired at the same time of SP observation(along track)
Support image line position of observation point (COLUMN)	Integral number without sign	2(0)	-	Position of observation point on support image of TC /MI image acquired at the same time of SP observation(cross track)
Thumbnail line position of observation point (LINE)	Integral number without sign	2(0)	-	Position of observation point on thumbnail of TC /MI image acquired at the same time of SP observation(along track)
Thumbnail line position of observation point (COLUMN)	Integral number without sign	2(0)	-	Position of observation point on thumbnail of TC /MI image acquired at the same time of SP observation(cross track)
Total		166(158)		

The numbers in ()in the column of "Byte" are the cases of L2B1 and L2B2.

(3)Spectrum data object

The specifications of SP spectrum data object are shown in the list of List 2.3-8. And byte orders in the List 2.3-8 are all big endian.

List 2.3-8 Specifications of SP spectrum data object

Kind of spectrum data	Type	Bit length	Number of valid pixels
Center wavelengths	Integral number without sign	16	296
Raw data spectrum	Integral number without sign	16	296
Dark current corrected value spectrum	Integral number without sign	16	296
Radiance value spectrum	Integral number without sign	16	296
(Diffusion) reflectance value spectrum	Integral number without sign	16	296
Ancillary and supplementary data spectrum	Integral number without sign	16	296
High level process result	Real number	32	128

Spectrum values of each band except high level process result are recorded in the following pixels.

On VIS 1~ 84, pixels of 1~ 84

On NIR1 1~100, pixels of 85~184

On NIR2 1~112, pixels of 296~185

On the high level process result, it records parameters of each observation point calculated by Level2D process. On the details of Leve2D process, they are described in the reference books (4).

2.3.4 SP original resolution JPEG image file

SP original resolution JPEG image file is made by saving TC or MI image acquired at the same time of SP observation as JPEG format at its original resolution. Before that, the TC or MI image is made dark current and flat field correction (only for MI), cut the compression dummies off, and scaled to 512 pixels or less. SP original resolution JPEG image file is included in SP L2B2 - L2D data set. However, depending on the parameter setting of RGC, it may not be included in them.

The direction of SP original resolution JPEG image file is same as the original TC/MI image, and is not rotated/reversed unlike in the case of SP thumbnail file,

The specifications of SP original resolution JPEG image file are described in the List 2.3-9.

List 2.3-9 Specifications of SP original resolution JPEG image file

Detector	Band number	File size	Format
TC	N/A	400kb or less	8bitJPEG
MI-VIS	2		
MI-NIR	3		











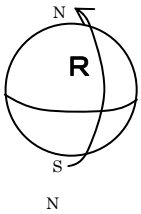



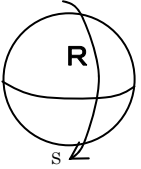



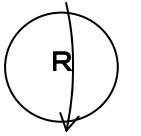



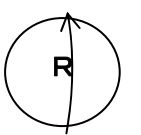

The band number is the default value.

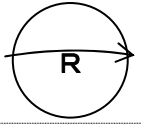
The file size is the default value.

Appendix1 "Rotation/reverse of the thumbnail image"

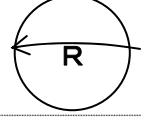
The cases in rotating/reversing the thumbnail image against the original image obtained by observing the letter "R" on the lunar surface are shown in the following list. (The upper left edge of the image is the first line and the first element. On TC, in the case of Full in Swath)

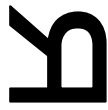
List A1-1 Rotation/reverse of the thumbnail image against the original image

		Moving direction of the spacecraft = +1 (without yaw around)		Moving direction of the spacecraft = -1 (with yaw around)	
		original	thumbnail	original	thumbnail
Ascending (A)					
		reverse up/down and right/left		reverse up/down	
Descending (D)					
		without rotation and reverse		reverse right/left	
Involving (a) pole(s) (N/S/W)					
					
					
					
		without rotation and reverse		reverse right/left	

The original images are arranged downward from the first line in order of its observation time, regarded their left edge as the first element, on the other hand the thumbnail images were rotated or reversed in such a way that whose north becomes up and east becomes right. But, on the images involving (a) pole(s), they should be subject to the observation direction, considering only the moving direction of the spacecraft.

Appendix2 "Details of the invalid pixel"

In the processing of each level/option, a pixel value might reach an abnormal value, so in order to identify such a situation, an invalid pixel value is set to that pixel of the image data object. Invalid pixel values and those meanings are shown in the list A2-1~2.

List A2-1 PDS labels related to invalid pixel described in the area of image data object

Item name of PDS label	Invalid pixel value	Meaning of invalid pixel value
INVALID_TYPE	-20000 ~ -23101	Invalid pixel attributed to sensor, L2A data, radiometric calibration or geometric correction (The details are given in the table shown below.)
OUT_OF_IMAGE_BOUNDS_VALUE	-30000	The pixel originally not existing before its resampling process

List A2-2 Invalid pixel type described in the area of image data object (INVALID_TYPE)

Brief description			Detail description		
INVALID_TYPE	INVALID_VALUE	Meaning of INVALID_VALUE	INVALID_TYPE	INVALID_VALUE	Meaning of INVALID_VALUE
SATURATION	-20000	The pixel value became saturated.	L2A_SATURATION	-20001	The pixel value of L2A data had been saturated.
			RAD_SATURATION	-20061	The pixel value became saturated in radiance conversion.
			PHASE_SATURATION	-20081	The pixel value became saturated in photometric correction.
			REF_SATURATION	-20091	The pixel value became saturated in reflectance conversion.
			RESAMPLE_SATURATION	-20101	The pixel value became saturated in its resampling process.
			SCALING_SATURATION	-20111	The pixel value became greater than maximum value of signed short integer (32767) in the process of converting physical quantity into DN value.
MINUS	-21000	The pixel value became minus.	DARK_MINUS	-21011	The pixel value became minus in dark current correction.
			MV_FT_MINUS	-21021	The pixel value became minus in MI-VIS frame transfer correction.
			PHASE_MINUS	-21081	The pixel value became minus in photometric correction.
			RESAMPLE_MINUS	-21101	The pixel value became minus in its resampling process.
DUMMY_DEFECT	-22000	The pixel had been L2A dummy pixel, or the detector element of the pixel had been defect element.	DUMMY	-22001	The pixel had been L2A dummy pixel.
			DEFECT	-22002	The detector element of the pixel had been defect element.
OTHER	-23000	Error other than listed above happened.	DEAD	-23001	The pixel had been L2A dead pixel.
			MV_FT_INCREASE_ERROR	-23021	The pixel value increased in MI-VIS frame transfer correction.
			MV_FT_FAILURE	-23022	MI-VIS frame transfer correction failed.
			PHASE_GEO_ERROR	-23081	Photometric correction failed because of invalid geometric data.
			PHASE_USGS_ZERO_DIVIDE	-23082	A division by zero happened in USGS photometric correction.
			RESAMPLE_ERROR	-23101	Resampling failed.

* Description of invalid pixel type (brief description / detail description) depends on parameter setting for the product creation. Briefly described invalid pixel type means any of detail invalid pixel types listed in the same row.

Appendix3 “Details of SP Ancillary Information”

Details of ancillary information, which is one of spectral data objects in a SP PDS product file are shown in Table B1-1.

Table B1-1. Details of ancillary information in a SP PDS product file

Bit number (From LSB to MSB)	Short description	Details
1-3	VIS dark data condition	VIS dark data = VIS data observed with solar elevation larger than 90 degree. 000 => VIS dark data exist at both end of a L2B1 product. 001 => VIS dark data exist only at the end of a L2B1 product. 010 => VIS dark data exist only at the beginning of a L2B1 product. 011 => No VIS dark data exist in a L2B1 product. 100 => All data in a L2B1 product are VIS dark data 101 => Anomalous data
4	Sign of S value	S value = original data - dark data 0 = S value is positive or zero, 1 = S value is negative.
5	Saturation	Saturation threshold = 50000 (original data) 0 = No saturation occurred, 1=Saturation occurred or data may be affected by saturation.
6-7	VIS wavelength shift	Unit of VIS wavelength shift = 6 nm (equal to VIS spectral sampling interval) 00 => VIS wavelength shift is less than 0.3. 01 => VIS wavelength shift is between 0.3 and 0.6. 10 => VIS wavelength shift is between 0.6 and 0.9. 11 => VIS wavelength shift is larger than 0.9.
8-9	VIS-NIR1 gap correction factor	VIS-NIR1 gap correction factor = Ratio between VIS and NIR1 radiance at same wavelength before gap correction 00 => The factor is between 0.9 and 1.0. 01 => The factor is between 1.0 and 1.1. 10 => The factor is between 1.1 and 1.2. 11 => The factor is less than 0.9 or larger than 1.2.
10-11	NIR1-NIR2 gap correction factor	NIR1-NIR2 gap correction factor = Ratio between NIR1 and NIR2 radiance at adjacent wavelength before gap correction 00 => The factor is less than 0.9. 01 => The factor is between 0.9 and 1.0. 10 => The factor is between 1.0 and 1.1. 11 => The factor is larger than 1.1.
12	Not used	
13	Not used	
14	Anomalous behavior of NIR1 longer end pixels	0 => normal 1 => anomalous
15	Anomalous behavior of VIS longer end and NIR1 shorter pixels	0 => normal 1 => anomalous
16	Dead pixels	0 => normal 1 => dead pixel

**KAGUYA (SELENE)
Product Format Description**

- LISM (TC/MI/SP) /SPICE Kernel-

Appendix-2

**LISM DTM / Ortho Product Format
Description**

Version 1.2

November 19, 2009

Change Log

Ver.	Date	Change	Remarks
1.0	09/11/1	The first edition	
1.1	09/11/6	-	
1.2	09/11/19	p.6(Table 2.1-2) "Strip Division Number" of the Catalog Information File was deleted.	

LISM DTM/Ortho Product File-Format Manual

Table of Contents

1. Outline	1
1.1 Purpose	1
1.2.2 Reference Documents.....	1
2. DTM Data Set.....	2
2.1 DTM-TC Ortho Data Set.....	2
2.1.1 Catalog Information File.....	5
2.1.2 Thumbnail File.....	8
2.1.3 PDS Label (For L2DB).....	9
2.1.4 Tar Object File.....	10
2.2 DTM Map	22
2.2.1 Catalog Information File.....	24
2.2.2 Thumbnail.....	26
2.2.3 PDS Product.....	27
2.2.4 Low-Resolution File.....	31
2.3 TC Ortho Map.....	32
2.3.1 Catalog Information File.....	34
2.3.2 Thumbnail.....	36
2.3.3 PDS Product.....	37
2.3.4 Low-Resolution File.....	41

1. Outline

1.1 Purpose

This document describes the formats of the Digital Terrain Model (DTM) Data Set. These files provided by Japan Aerospace Exploration Agency (JAXA).

1.2.2 Reference Documents

- (1) Planetary Data System Standards Reference Version 3.5
- (2) SPK Required Reading (05-Sep-2002, NAIF Document No.168.10)
- (3) CK Required Reading (05-Sep-2002, NAIF Document No.174.08)
- (4) SCLK Required Reading (06-Oct-1999, NAIF Document No.222.02)
- (5) Digital compression and coding of continuous-tone still images (ISO/IEC 10918-1)

2. DTM Data Set

2.1 DTM-TC Ortho Data Set

The DTM-TC Ortho Data Set is the set of DTM and TC Ortho data generated for each scene. It is a tar archive composed of the following four files.

- Catalog Information file
- Tar Object file (DTM PDS Product)
- Thumbnail file
- PDS Label

Figure 2.1-1 outlines the configuration of the DTM-TC Ortho Data Set, and Fig. 2.1-2 outlines the configuration of the Tar Object.

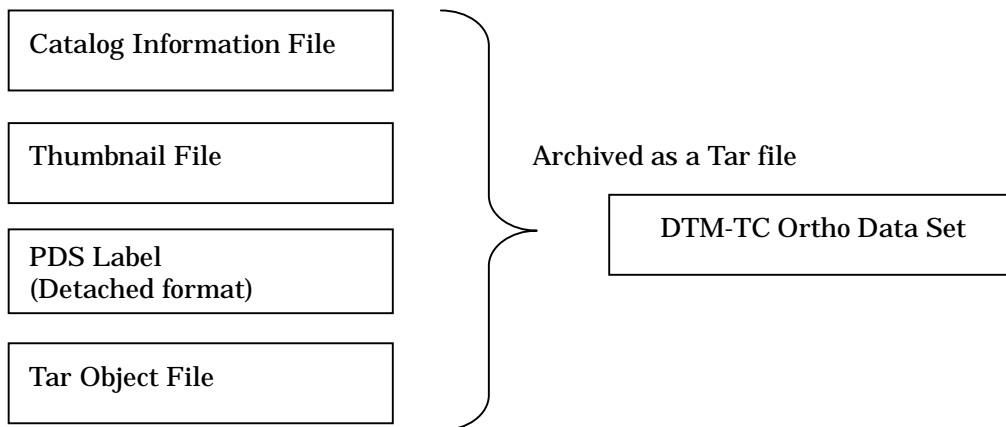

Fig. 2.1-1 Configuration of the DTM-Ortho Data Set

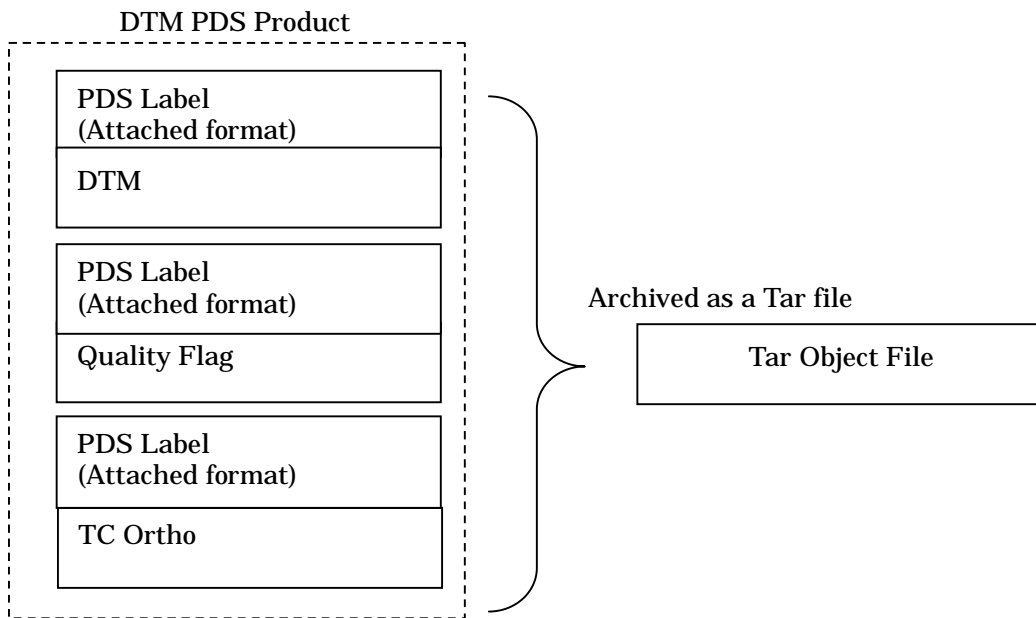

Fig. 2.1-2 Configuration of the Tar Object

Table 2.1-1 presents the file-naming rules for each of the above-mentioned files, described in detail in the following paragraphs.

Table 2.1-1 File-Naming Rules for the DTM-TC Ortho Data Set File

(Exp. DTMTCO_nn_99999N550E2700SC.tgz)

Code	Start Position	Length (Byte)	Preset Values
1	1	6	Product type "DTMTCO" fixed
2	7	1	Underscore "_" fixed
3	8	2	L2DB version nn: 2 digits
4	10	1	Underscore "_" fixed
5	11	5	Revolution number nnnnnn: 5 digits
6	16	4	Latitude S900 to N900 Unit: more than the first decimal place
7	20	5	Longitude E0000 to E3600 Unit: more than the first decimal place
8	25	2	Map projection "SC": Simple cylindrical "PS": Polar stereo
9	27	4	Extensions .tgz: Tar Object .jpg: Thumbnail .ctg: Catalog Information .sl2: DTM Data Set .lbl: PDS Label .dtm: DTM .img: TC Ortho .dqa: Quality Flag
Total	-	30	

2.1.1 Catalog Information File

The Catalog Information File is an attached Information File outlining the DTM-TC Ortho Data Set and defining the items that can be used to retrieve products from the L2DB subsystem.

Tables 2.1-2 and 2.1-3 describe the items of the Catalog Information File of the DTM-TC Ortho product. Each item is described in the following format within 1 line.

Format:

Keyword = String Value

In the "Comment" of the Catalog Information File, multiple comma-delimited items (Table 2.1-4) are described in the following format.

Format:

CommentInfo = Keyword1 = "String Value", Keyword2 = "String Value", ...

Unless otherwise specified, the basic principle is that the numeric value of each item should be zero suppressed; the string value of each item should contain no space character, and be left-aligned.

Table 2.1-2 Items of the Catalog Information File (DTM-TC Ortho)

Item	Keyword	Format of Preset Value	Content of Preset Value
Data File Name	DataFileName	AAAA...AAAA (31 digits)	DTM-TC ortho file name
Data File Size	DataFileSize	NNNNNNNNNNNN (Max. 12 digits)	DTM-TC ortho file size <byte>
Data File Format	DataFileFormat	AAAA...AAAA (Max. 16 digits)	DTM-TC ortho file format
Thumbnail File Name	ThumbnailFileName	AAAA...AAAA (Max. 65 digits)	Thumbnail file name
Thumbnail File Size	ThumbnailFileSize	NNNNNNNNNNNN (Max. 12 digits)	Thumbnail file size <byte>
Thumbnail File Format	ThumbnailFileFormat	AAAA (Max. 4 digits)	JPEG: fixed
Instrument Name	InstrumentName	AAAA...AAAA (Max. 16 digits)	LISM: fixed
Processing Level	ProcessingLevel	AAAA...AAAA (Max. 16 digits)	L3D: fixed
Product ID	ProductID	AAAA...AAAA (Max. 30 digits)	DTM_TCOrtho, DTM_TCOrtho_S
Product Version	ProductVersion	AAAA...AAAA (Max. 16 digits)	nn: L2DB version
Access Level	AccessLevel	N	0: Read only 1: LISM core members only 2: LISM members only 3: SELENE members only 4: All members
Start Date and Time	StartDateTime	yyyy-mm-ddT hh:mm:ss.sssssZ	

End Date and Time	EndDateTime	<i>yyyy-mm-ddT hh:mm:ss.sssssZ</i>	
Revolution Number	RevoNumber	NNNNNNNNNN (Max. 10 digits)	
Scene Number	SceneNumber	NNNNNNNNNN (Max. 10 digits)	
Strip Number	StripNumber	NNNNNNNNNN (Max. 10 digits)	
Location Flag	LocationFlag	A	"A": Ascending "D": Descending "N": When containing the imaging time which changes from the ascending to the descending "S": When containing the imaging time which changes from the descending to the ascending
Upper Left Latitude	UpperLeftLatitude	SNN.NNNNNN	<degree>
Upper Left Longitude	UpperLeftLongitude	NNN.NNNNNN	<degree>
Upper Right Latitude	UpperRightLatitude	SNN.NNNNNN	<degree>
Upper Right Longitude	UpperRightLongitude	NNN.NNNNNN	<degree>
Lower Left Latitude	LowerLeftLatitude	SNN.NNNNNN	<degree>
Lower Left Longitude	LowerLeftLongitude	NNN.NNNNNN	<degree>
Lower Right Latitude	LowerRightLatitude	SNN.NNNNNN	<degree>
Lower Right Longitude	LowerRightLongitude	NNN.NNNNNN	<degree>
Scene Center Latitude	SceneCenterLatitude	SNN.NNNNNN	<degree>
Scene Center Longitude	SceneCenterLongitude	NNN.NNNNNN	<degree>
Comment	CommentInfo	AAAA...AAAA (Max 4000 digits)	(see Table 2.1-4)
Free Keywords	FreeKeyword	-	(see Table 2.1-3)

Table 2.1-3 Free Keywords in the Catalog Information File (DTM-TC Ortho)

Item	Keyword	Format of Preset Value	Content of Preset Value
DTM Minimum Value	DTMMinimum	SNNNNN	<m>
DTM Maximum Value	DTMMaximum	SNNNNN	<m>
DTM Mean Value	DTMAverage	SNNNNN	<m>
DTM Standard Deviation	DTMStdev	NNNNN	<m>
DTM Mode Pixel Value	DTMModePixel	SNNNNN	<m>
TCO Maximum Value	TCOMaximum	NNNN	
TCO Mean Value	TCOAverage	NNNN	
TCO Standard Deviation	TCOStdev	NNNN	
TCO Mode Pixel Value	TCOModePixel	NNNN	
Dummy Pixel Percentage	DTMQAPercentDummyPixel	NNN	<%>
Bad Pixel Percentage	DTMQAPercentBadPixel	NNN	<%>
Shadow Pixel Percentage	DTMQAPercentShadowPixel	NNN	<%>
Scene Center Incidence Angle	IncidenceAngle	NNN.NNN	<degree>
Scene Center Emission Angle	EmissionAngle	NNN.NNN	<degree>
Scene Center Phase Angle	PhaseAngle	NNN.NNN	<degree>
Scene Center Solar Azimuth	SolarAzimuth	NNN.NNN	<degree>
Spacecraft Altitude	SpacecraftAltitude	NNN...NNN	Spacecraft altitude of the first line ("distance between spacecraft and lunar gravitational center" minus average lunar radius) <km>
DPU Temperature	DPUTemperature	NNN...NNN	<degC>

Table 2.1-4 Comments in the Catalog Information File (DTM-TC Ortho)

Item	Keyword	Format of Preset Value	Content of Preset Value
Product Creation Date	ProductCreationTime	<i>yyyy-mm-ddThh:mm:ssZ</i>	
Base L2A Data File Name	BaseLevel2AFileName	AAAA...AAAA (Max. 31 digits)	
Mission Phase Name	MissionPhaseName	AAAA...AAAA	
Qtable ID	QtableID	AAAA...AAAA	
Huffman Table ID	HuffmanTableID	AAAA...AAAA	

2.1.2 Thumbnail File

Thumbnails included in the DTM-TC Ortho Data Set are reduced-size TC Ortho images with JPEG compression, though the DTM-TC Ortho Data Set contains three types of image data (DTM, TC Ortho, and Quality Flag).

Refer to ISO-IEC 10918-1 for the JPEG format. Table 2.1-5 provides the specifications for the thumbnails.

Table 2.1-5 Specifications for the Thumbnail Files

Number of Pixels	Number of Lines	File Size	Format
512 or less	512 or less	100kb or less	JPEG

2.1.3 PDS Label (For L2DB)

The PDS Label for L2DB is concomitant with a Tar Object File of the DTM-TC Ortho Data Set. Figure 2.1-3 depicts the configuration of the PDS Label (for L2DB), and Table 2.1-6 details the items of the PDS Label.

PDS Label	PDS Label Common Items	
	Object Position Specification	
	Product Information	File Attributes Product Attributes

Fig. 2.1-3 Configuration of the PDS Label for use with L2DB

Table 2.1-6 Items of the PDS Label File for L2DB

Category	Name	Description form	Explanation	Value
PDS label common items				
	PDS version ID	PDS_VERSION_ID = "%s"	PDS version ID	"PDS3" fixed
	File record type	RECORD_TYPE = "%s"	File record type	"UNDEFINED" fixed
	File name	FILE_NAME = "%s"	File name of this product (product ID + extension)	
	Product ID	PRODUCT_ID = "%s"	Unique ID given to every product	
	Data file format ID	DATA_FORMAT = "%s"	Data file format ID	"PDS" fixed
Object position specification				
		OBJECT = ARCHIVE_FILE		
	File name	FILE_NAME = "%s"	File name of the tar object	
	Archive type	ARCHIVE_TYPE = "%s"	How archived	"TAR" fixed
	Compression type	ENCODING_TYPE = "%s"	How compressed	"GZIP" fixed
	Number of archived files	ARCHIVE_FILES = %d	Total number of files contained in the tar object	3 fixed
	Archive files	ARCHIVE_FILE_NAME = ("%s", "%s", "%s")	Names of the files contained in the tar object	
	File size after extraction	REQUIRED_STORAGE_BYTES = %d	Total file size after extracting tar object <byte>	
		END_OBJECT = ARCHIVE_FILE		
Product information				
	File attributes			
	Processing level	PROCESS_VERSION_ID = "%s"	Processing level ID	"L3D": DTM/TC ortho, DTM mosaic, and TC ortho mosaic "MAP": DTM map, and TC ortho map
	Product attributes			
	Product set ID	PRODUCT_SET_ID = "%s"	Product set ID	"DTM_TCOrtho": DTM/TC ortho "DTM_MAP": DTM map "TCOrtho_MAP": TC ortho map "DTM_TCOrtho_S": DTM/TC ortho (special product) "DTM_MAP_S": DTM map (special product) "TCOrtho_MAP_S": TC ortho map (special product) "DTM_MSC": DTM mosaic (special product) "TCOrtho_MSC": TC ortho mosaic (special product)
	Product version ID	PRODUCT_VERSION_ID = "%s"	Product version ID	"01" to "99"
		END		

2.1.4 Tar Object File

The Tar Object File is composed of three DTM PDS product files (attached format).

Figure 2.1-4 illustrates the configuration of the Tar Object, and Fig. 2.1-5 presents the configuration of the DTM PDS Product.

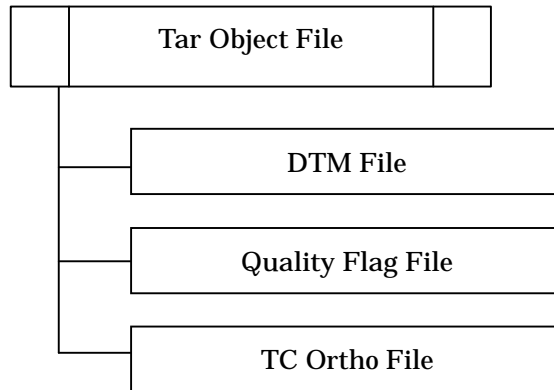

Fig. 2.1-4 Configuration of the Tar Object

PDS Label	PDS Label Common Items	
	Object Position Specification	
	Product Information	File Attributes
		Product Attributes
		Scene Attributes
		Image Map Projection
		Processing Parameter Description
		Image Information
		Quality Information
	Base L2A Source Data Information	
Image Data Object	DTM, TC Ortho and Quality Flag	

Fig. 2.1-5 Structure of the DTM PDS Product File

(1) PDS Label

The PDS Label of each DTM PDS product (DTM, Quality Flag, or TC Ortho) is added as an attached file to each product file.

Tables 2.1-7 to 2.1-9 detail the items of the PDS Label.

Table 2.1-7 Items of the PDS Label (DTM File)

Category	Name	Description form	Explanation	value
PDS label common items				
	PDS version ID	PDS_VERSION_ID = "%s"	PDS version ID	"PDS3" fixed
	File record type	RECORD_TYPE = "%s"	File record type	"UNDEFINED" fixed
	File name	FILE_NAME = "%s"	File name of this product (product ID + extension)	"
	Product ID	PRODUCT_ID = "%s"	Unique ID given to every product	"
	Data file format ID	DATA_FORMAT = "%s"	Data file format ID	"PDS" fixed
Object position specification				
	Head position of image object	^IMAGE = \$!0d <BYTES>	Head position of the image object	"
Product information				
	File attributes			
	Software name	SOFTWARE_NAME = "%s"	Software name that created the DTM PDS product	TBD
	Software version	SOFTWARE_VERSION = "%s"	Software version that created the DTM PDS product	"n.n.n" (TBD)
	Processing level	PROCESS_VERSION_ID = "%s"	Processing level ID	"L3D": DTM/TC ortho, DTM mosaic, and TC ortho mosaic "MAP": DTM map, and TC ortho map
	Product creation time	PRODUCT_CREATION_TIME = %s	Product creation time	YYYY-MM-DDTHH:MM:SSZ
	Product attributes			
	Producer ID	PRODUCER_ID = "%s"	Data producer ID	"LISM" fixed
	Product set ID	PRODUCT_SET_ID = "%s"	Product set ID	"DTM_TCOrtho": DTM/TC ortho "DTM_MAP": DTM map "TCOrtho_MAP": TC ortho map "DTM_TCOrtho_S": DTM/TC ortho (special product) "DTM_MAP_S": DTM map (special product) "TCOrtho_MAP_S": TC ortho map (special product) "DTM_MSC": DTM mosaic (special product) "TCOrtho_MSC": TC ortho mosaic (special product)
	Product version ID	PRODUCT_VERSION_ID = "%s"	Product version ID	"01" to "99"
	Base L2A data file name	BASE_LEVEL2A_FILE_NAME = "%s"	L2A data file name of the base image used for DTM creating	"
	Reference L2A data file name	REFERENCE_LEVEL2A_FILE_NAME = {"%s", "%s", ...}	L2A data file names of all reference images used for DTM creating	"
	SPICE kernel file name (SPK)	SPICE_SPK_FILE_NAME = {"%s", "%s", ...}	All SPICE kernel (SPK) names used for DTM/ortho product creating	"
	SPICE kernel file name (PK)	SPICE_PCK_FILE_NAME = {"%s", "%s", ...}	All SPICE kernel (PK) names used for DTM/ortho product creating	"
	SPICE kernel file name (IK)	SPICE_IK_FILE_NAME = {"%s", "%s", ...}	All SPICE kernel (IK) names used for DTM/ortho product creating	"
	SPICE kernel file name (CK)	SPICE_CK_FILE_NAME = {"%s", "%s", ...}	All SPICE kernel (CK) names used for DTM/ortho product creating	"
	SPICE kernel file name (SCLK)	SPICE_SCLK_FILE_NAME = {"%s", "%s", ...}	All SPICE kernel (SCLK) names used for DTM/ortho product creating	"
	SPICE kernel file name (LSK)	SPICE_LSK_FILE_NAME = {"%s", "%s", ...}	All SPICE kernel (LSK) names used for DTM/ortho product creating	"
	Scene attributes			
	Mission name	MISSION_NAME = "%s"	Mission name	"SELENE" fixed
	Spacecraft name	SPACECRAFT_NAME = "%s"	Spacecraft name	"SELENE-M" fixed
	Data set ID	DATA_SET_ID = "%s"	This data set ID	TBD
	Instrument name	INSTRUMENT_NAME = "%s"	Full name of the Instrument name	"Terrain Camera"
	Instrument ID	INSTRUMENT_ID = "%s"	Instrument ID	"TC"
	Upper left latitude	UPPER_LEFT_LATITUDE = \$!0.6f <deg>	Latitude at the center of the upper-left corner pixel of the image that contains dummy pixels	-90 to 90
	Upper left longitude	UPPER_LEFT_LONGITUDE = \$!0.6f <deg>	Longitude at the center of the upper-left corner pixel of the image that contains dummy pixels	0 to 360
	Upper right latitude	UPPER_RIGHT_LATITUDE = \$!0.6f <deg>	Latitude at the center of the upper-right corner pixel of the image that contains dummy pixels	-90 to 90
	Upper right longitude	UPPER_RIGHT_LONGITUDE = \$!0.6f <deg>	Longitude at the center of the upper-right corner pixel of the image that contains dummy pixels	0 to 360
	Lower left latitude	LOWER_LEFT_LATITUDE = \$!0.6f <deg>	Latitude at the center of the lower-left corner pixel of the image that contains dummy pixels	-90 to 90
	Lower left longitude	LOWER_LEFT_LONGITUDE = \$!0.6f <deg>	Longitude at the center of the lower-left corner pixel of the image that contains dummy pixels	0 to 360
	Lower right latitude	LOWER_RIGHT_LATITUDE = \$!0.6f <deg>	Latitude at the center of the lower-right corner pixel of the image that contains dummy pixels	-90 to 90
	Lower right longitude	LOWER_RIGHT_LONGITUDE = \$!0.6f <deg>	Longitude at the center of the lower-right corner pixel of the image that contains dummy pixels	0 to 360
	Image center latitude	IMAGE_CENTER_LATITUDE = \$!0.6f <deg>	Latitude at the center pixel of the image	-90 to 90
	Image center longitude	IMAGE_CENTER_LONGITUDE = \$!0.6f <deg>	Longitude at the center pixel of the image	0 to 360
	Location flag	LOCATION_FLAG = "%s"	Spacecraft location information	"A": Ascending "D": Descending "N": When containing the imaging time which changes from the ascending to the descending "S": When containing the imaging time which changes from the descending to the ascending
	Distance between the Moon and the Sun	MOON_SUN_DISTANCE = \$d <km>	Distance between the Moon and the Sun	"
Map projection information				
	Map projection	MAP_PROJECTION_TYPE = "%s"	Name of the map projection	"Simple Cylindrical", "Stereographic", "Lambert Conformal" or "Transverse Mercator"
	Coordinate system type	COORDINATE_SYSTEM_TYPE = "%s"	Type of the coordinate system	"BODY-FIXED ROTATING" fixed
	Coordinate system name	COORDINATE_SYSTEM_NAME = "%s"	Full name of the coordinate system	"PLANETOCENTRIC" fixed
	A axis radius	A_AXIS_RADIUS = \$8.3f <km>	A axis radius of the Moon	1737.4 <KM> default
	B axis radius	B_AXIS_RADIUS = \$8.3f <km>	B axis radius of the Moon	1737.4 <KM> default
	C axis radius	C_AXIS_RADIUS = \$8.3f <km>	C axis radius of the Moon	1737.4 <KM> default
	First standard parallel	FIRST_STANDARD_PARALLEL = \$!0.6f <deg>	First standard parallel Used for "Lambert Conformal" projection	-90 to 90 for "Lambert Conformal" projection "N/A" for other map projection
	Second standard parallel	SECOND_STANDARD_PARALLEL = \$!0.6f <deg>	Second standard parallel Used for "Lambert Conformal" projection	-90 to 90 for "Lambert Conformal" projection "N/A" for other map projection
	Positive longitude direction	POSITIVE_LONGITUDE_DIRECTION = "%s"	Positive direction of longitude	"EAST" fixed

Center latitude	CENTER_LATITUDE = %10.6f <deg>	Latitude at the origin in a given MAP_PROJECTION_TYPE	-90 to 90
Center longitude	CENTER_LONGITUDE = %10.6f <deg>	Longitude at the origin in a given MAP_PROJECTION_TYPE	0 to 360
Reference latitude	REFERENCE_LATITUDE = %10.6f <deg>	Zero latitude in a rotated spherical coordinate system that was used in a given MAP_PROJECTION_TYPE	"N/A" fixed
Reference longitude	REFERENCE_LONGITUDE = %10.6f <deg>	Zero longitude in a rotated spherical coordinate system that was used in a given MAP_PROJECTION_TYPE	"N/A" fixed
First line number	LINE_FIRST_PIXEL = %d	Line number of the upper end pixel of the image	1 fixed
Last line number	LINE_LAST_PIXEL = %d	Line number of the lower end pixel of the image	
First sample number	SAMPLE_FIRST_PIXEL = %d	Sample number of the left end pixel of the image	1 fixed
Last sample number	SAMPLE_LAST_PIXEL = %d	Sample number of the right end pixel of the image	
Map orientation angle	MAP_PROJECTION_ROTATION = %f <deg>	Clockwise rotation of the line and sample coordinates with respect to the map projection origin	0.0 fixed
Map resolution	MAP_RESOLUTION = %f <pixel/deg>	Total number of pixels in a box area of 1-degree latitude x 1-degree longitude for Simple Cylindrical Projection	"N/A" is given when MAP_PROJECTION_TYPE is not "Simple Cylindrical".
Map scale	MAP_SCALE = %f <km/pixel>	Actual distance, in km, between two points at the origin in a given MAP_PROJECTION_TYPE	
Maximum latitude	MAXIMUM_LATITUDE = %10.6f <deg>	Latitude at the center of the northernmost pixel in 4 corner pixels	-90 to 90
Minimum latitude	MINIMUM_LATITUDE = %10.6f <deg>	Latitude at the center of the southernmost pixel in 4 corner pixels	-90 to 90
Easternmost longitude	EASTERMOST_LONGITUDE = %10.6f <deg>	Longitude at the center of the easternmost pixel in 4 corner pixels	0 to 360
Westernmost longitude	WESTERNMOST_LONGITUDE = %10.6f <deg>	Longitude at the center of the westernmost pixel in 4 corner pixels	0 to 360
Line projection offset	LINE_PROJECTION_OFFSET = %f	Map projection coordinates, in pixels, at the center of the upper-left corner pixel of this image	
Sample projection offset	SAMPLE_PROJECTION_OFFSET = %f	Map projection coordinates, in pixels, at the center of the upper-left corner pixel of this image	
Resampling method	RESAMPLING_METHOD = "%s"	Image resampling method	"Nearest Neighbor", "Bi-linear", "Cubic Convolution" or "Logical Sum"
	END_OBJECT = IMAGE_MAP_PROJECTION		
Processing parameter description			
	OBJECT = PROCESSING_PARAMETERS		
Parameter set name	PARAMETER_SET_NAME = "%s"	Name of the processing parameter set	TBD
	END_OBJECT = PROCESSING_PARAMETERS		
Image information			
	OBJECT = IMAGE		
Bands	BANDS = %d	Total number of bands in this image	1 fixed
Band storage type	BAND_STORAGE_TYPE = "%s"	Storage sequence of lines, samples, and bands in this image	"BAND_SEQUENTIAL" fixed
Band name	BAND_NAME = "%s"	Spectral range(s) associated with each band in single-band or multi-band data	"N/A" fixed
Lines	LINES = %d	Total number of lines in this image	
Line samples	LINE_SAMPLES = %d	Total number of pixels in a line	
Sample type	SAMPLE_TYPE = "%s"	Image data type	"MSB_INTEGER" (DTM) or "MSB_UNSIGNED_INTEGER" (TC ortho)
Sample bits	SAMPLE_BITS = %d	Total number of bits used to store one data sample value	8 or 16
Meaning of pixel value	IMAGE_VALUE_TYPE = "%s"	Meaning of the value of the pixel	"DN", "RADIANCE", "REFLECTANCE" or "ELEVATION"
Sample bit mask	SAMPLE_BIT_MASK = %s	Active bits in a sample	2#11111111#; 8 bits 2#1111111111111111#; 16 bits
Offset	OFFSET = %f	Offset value used in the DN for physical quantity conversion	
		DTM and DTM map: Elevation DN*SCALING_FACTOR-OFFSET = Unit is "meter" from the Moon radius TC ortho and TC ortho map (REF_CNV_SW="OFF"): Radiance DN*SCALING_FACTOR-OFFSET = Unit is "w/m2/μ m/sr" TC ortho map (REF_CNV_SW="ON"): Reflectivity DN*SCALING_FACTOR-OFFSET = Unit is "%"	
Scaling factor	SCALING_FACTOR = %f	Gain used in the DN for physical quantity conversion	
Stretched flag	STRETCHED_FLAG = "%s"	Whether a data object has been stretched to make it easy to see	"FALSE" fixed
Valid minimum	VALID_MINIMUM = %d	Minimum value that is valid for a data object	-9999: DTM 2: TC ortho
Valid maximum	VALID_MAXIMUM = %d	Maximum value that is valid for a data object	32766 fixed
Dummy	DUMMY = %d	Indicates the dummy (blank) pixel of the image	-9999: DTM 0: TC ortho
Minimum	MINIMUM = %d	Minimum value in this image except the invalid pixels	When the total number of valid pixels is 0, the value of DTM is set to -9999 and the value of the TC ortho is set to -1.
Maximum	MAXIMUM = %d	Maximum value in this image except the invalid pixels	When the total number of valid pixels is 0, the value of DTM is set to -9999 and the value of the TC ortho is set to -1.
Average	AVERAGE = %f	Average value in this image except the invalid pixels	When the total number of valid pixels is 0, the value of DTM is set to -9999 and the value of the TC ortho is set to -1.
Standard deviation	STDEV = %f	Standard deviation in this image except the invalid pixels	When the total number of valid pixels is 0, the value of DTM is set to -9999 and the value of TC ortho is set to -1.
Mode pixel	MODE_PIXEL = %d	Mode in this image except the invalid pixels	When the total number of valid pixels is 0, the value of DTM is set to -9999 and the value of TC ortho is set to -1.
	END_OBJECT = IMAGE		
Quality information			
	OBJECT = QUALITY_INFO		
Quality flag file name	QA_FILENAME = "%s"	Name of quality flag file	
Good pixel percentage	QA_PERCENT_GOOD_PIXEL = %f	Percentage of good pixels in all the DTM pixels	Total number of QA_PERCENT_GOOD_PIXEL, QA_PERCENT_DUMMY_PIXEL and QA_PERCENT_BAD_PIXEL is 100.0

Dummy pixel percentage	QA_PERCENT_DUMMY_PIXEL = %f	Percentage of dummy pixels in all the DTM pixels	
Bad pixel percentage	QA_PERCENT_BAD_PIXEL = %f	Percentage of bad pixels in all the DTM pixels	
Interpolated pixel percentage	QA_PERCENT_INTERPOLATED_PIXEL = %f	Percentage of interpolated pixels in all the DTM pixels	
Shadow pixel percentage	QA_PERCENT_SHADOW_PIXEL = %f	Percentage of shadowed pixels in all the DTM pixels	
Correlation threshold of bad pixel	BAD_PIXEL_THRESHOLD_CORRELATION = %f	Threshold of image correlation between stereo images to extract the bad pixel from the DTM	
Slope threshold of bad pixel	BAD_PIXEL_THRESHOLD_SLOPE = %f <deg>	Slope angle threshold to extract the bad pixel from the DTM	
	END_OBJECT = QUALITY_INFO		
Base L2A source data information			
	OBJECT = SOURCE_L2A_DATA_INFO		
L2A file name	FILE_NAME = "%s"	File name of the L2A product	
L2A creation time	PRODUCT_CREATION_TIME = %s	L2A product data creation time	YYYY-MM-DDTHH:MM:SSZ
Execution count	EXECUTION_COUNT = %d	Execution count of the L2A product	
Illumination condition	ILLUMINATION_CONDITION = "%s"	Illumination condition	"MORNING" or "EVENING"
L0 file name	LEVEL0_FILE_NAME = {"%s","%s",...}	File names of all the L0 data used for creating L2A	
Spacecraft time correction file name	SC_TIME_CORRECTION_FILE_NAME = {"%s","%s",...}	File names of all the spacecraft time correction files used for creating L2A	
Orbit data file name	ORBIT_DATA_FILE_NAME = {"%s","%s",...}	File names of all the orbit data files used for creating L2A	
Attitude data file name	ATTITUDE_DATA_FILE_NAME = {"%s","%s",...}	File names of all the attitude data files used for creating L2A	
Revolution number file name	REVOLUTION_NUMBER_FILE_NAME = {"%s","%s",...}	File names of all the revolution number files used for creating L2A	
HK mission file name	HK_MISSION_FILE_NAME = {"%s","%s",...}	File names of all the mission instrument HK files used for creating L2A	
SPICE kernel (SPK) file name	SPICE_SPK_FILE_NAME = {"%s","%s",...}	File names of all the SPICE kernel (SPK) files used for creating L2A	
SPICE kernel (Pck) file name	SPICE_PCK_FILE_NAME = {"%s","%s",...}	File names of all the SPICE kernel (Pck) files used for creating L2A	
SPICE kernel (IK) file name	SPICE_IR_FILE_NAME = {"%s","%s",...}	File names of all the SPICE kernel (IK) files used for creating L2A	
SPICE kernel (CK) file name	SPICE_CK_FILE_NAME = {"%s","%s",...}	File names of all the SPICE kernel (CK) files used for creating L2A	
SPICE kernel (SCLK) file name	SPICE_SCLK_FILE_NAME = {"%s","%s",...}	File names of all the SPICE kernel (SCLK) files used for creating L2A	
SPICE kernel (LSK) file name	SPICE_LSK_FILE_NAME = {"%s","%s",...}	File names of all the SPICE kernel (LSK) files used for creating L2A	
Scene definition file name	SCENE_DEFINITION_FILE_NAME = "%s"	File name of the scene definition file used for creating L2A	
Threshold file name	THRESHOLD_FILE_NAME = "%s"	Threshold file name	
Conversion table file name	CONVERSION_TABLE_FILE_NAME = "%s"	Engineering value translated for table file	
Instrument name	INSTRUMENT_NAME = "%s"	Full name of the instrument	"Terrain Camera 1" or "Terrain Camera 2"
Instrument ID	INSTRUMENT_ID = "%s"	Instrument ID	"TC1" or "TC2"
Revolution number	REVOLUTION_NUMBER = %d	Revolution number	
Strip sequence number	STRIP_SEQUENCE_NUMBER = %d	Strip number in the revolution	
Scene sequence number	SCENE_SEQUENCE_NUMBER = %d	Scene number in the strip	
Mission phase name	MISSION_PHASE_NAME = "%s"	Mission phase name	"Nominal", "Option", etc.
Upper left daytime flag	UPPER_LEFT_DAYTIME_FLAG = "%s"	Sunshine condition at the upper left pixel and the upper right pixel of the image	"Day" or "Night"
Upper right daytime flag	UPPER_RIGHT_DAYTIME_FLAG = "%s"		
Lower left daytime flag	LOWER_LEFT_DAYTIME_FLAG = "%s"	Sunshine condition at the lower left pixel and the lower right pixel of the image	"Day" or "Night"
Lower right daytime flag	LOWER_RIGHT_DAYTIME_FLAG = "%s"		
Target name	TARGET_NAME = "%s"	Observation target name of this strip	"MOON" default
Observation mode ID	OBSERVATION_MODE_ID = "%s"	Observation mode ID	"NORMAL" or "SUPPORT"
Sensor Description	SENSOR_DESCRIPTION = "%s"	Sensor specifications	
Sensor Description2	SENSOR_DESCRIPTION2 = "%s"	Spare sensor information	
Detector status	DETECTOR_STATUS {"TC1:%s","TC2:%s","MV:%s","MI:%s","SP:%s"}	ON/OFF of each of 5 powers (TC1, TC2, MI-VIS, MI-NIR, SP) in this scene center	
Exposure mode ID	EXPOSURE_MODE_ID = "%s"	Exposure mode ID	"LONG", "MIDDLE", "SHORT"
Spacecraft clock start count (TI)	SPACECRAFT_CLOCK_START_COUNT = %15.4f <sec>	Spacecraft clock count at the 1st line (TI)	
Spacecraft clock stop count (TI)	SPACECRAFT_CLOCK_STOP_COUNT = %15.4f <sec>	Spacecraft clock count at the last line (TI)	
Corrected spacecraft clock start count (TI)	CORRECTED_SC_CLOCK_START_COUNT = %17.6f <sec>	Corrected spacecraft clock count at the 1st line (TI)	
Corrected spacecraft clock stop count (TI)	CORRECTED_SC_CLOCK_STOP_COUNT = %17.6f <sec>	Corrected spacecraft clock count at the last line (TI)	
Start time (UT)	START_TIME = %s	Imaging time at the 1st line (UT)	YYYY-MM-DDTHH:MM:SS.sssssZ
Stop time (UT)	STOP_TIME = %s	Imaging time at the last line (UT)	YYYY-MM-DDTHH:MM:SS.sssssZ
Corrected start time (UT)	CORRECTED_START_TIME = %s	Corrected imaging time at the 1st line (UT)	YYYY-MM-DDTHH:MM:SS.sssssZ
Corrected stop time (UT)	CORRECTED_STOP_TIME = %s	Corrected imaging time at the last line (UT)	YYYY-MM-DDTHH:MM:SS.sssssZ
Location flag	LOCATION_FLAG = "%s"	Spacecraft location information	"A": Ascending "D": Descending "N": When containing the imaging time which changes from the ascending to the descending "S": When containing the imaging time which changes from the descending to the ascending
Roll cant	ROLL_CANT = "%s"	Distinction whether nadir-view observation or roll-cant observation	"YES": roll-cant observation "NO": nadir-view observation
Incidence angle	INCIDENCE_ANGLE = %7.3f <deg>	Incidence angle at the scene center	
Emission angle	EMISSION_ANGLE = %7.3f <deg>	Emission angle at the scene center	
Phase angle	PHASE_ANGLE = %7.3f <deg>	Phase angle at the scene center	
Solar azimuth angle	SOLAR_AZIMUTH_ANGLE = %7.3f <deg>	Solar azimuth angle at the scene center	
Focal plane temperature	FOCAL_PLANE_TEMPERATURE = %6.2f <degC>	Detector temperature at the 1st line	
Telescope temperature	TELESCOPE_TEMPERATURE = %6.2f <degC>	Telescope temperature at the 1st line	
Line exposure duration	LINE_EXPOSURE_DURATION = %10.6f <msec>	Line exposure duration	
Line sampling interval	LINE_SAMPLING_INTERVAL = %10.6f <msec>	Designed value of sampling interval	
Corrected sampling interval	CORRECTED_SAMPLING_INTERVAL = %10.6f <msec>	Sampling interval corrected by dividing the corrected interval time between first line and last line of strip into the number of lines	
Satellite moving	SATELLITE_MOVING_DIRECTION = "%s"	Satellite moving direction	"-1": lead of -x plane

direction			"-1": lead of -x plane
Qtable ID	Q_TABLE_ID = "%s"	Qtable ID	
Huffman table ID	HUFFMAN_TABLE_ID = "%s"	Huffman table ID	
Data compression percentage mean	DATA_COMPRESSION_PERCENT_MEAN = %5.1f	Mean compression percentage in the scene	
Data compression percentage maximum	DATA_COMPRESSION_PERCENT_MAX = %5.1f	Maximum compression percentage in the scene	
Data compression percentage minimum	DATA_COMPRESSION_PERCENT_MIN = %5.1f	Minimum compression percentage in the scene	
Defect pixel position	DEFECT_PIXEL_POSITION = (%d,%d,...)	Detector number of the defect pixels	
Constant dummy pixels	CONSTANT_DUMMY_PIXELS = %d	Total number of dummy pixels for the compression	
Swath mode ID	SWATH_MODE_ID = "%s"	Name of the swath mode	"NOMINAL", "FULL" or "HALF"
First pixel number	FIRST_PIXEL_NUMBER = %d	Detector number of the first sample pixel	
Last pixel number	LAST_PIXEL_NUMBER = %d	Detector number of the last sample pixel	
Spacecraft altitude	SPACECRAFT_ALTITUDE = %8.3f <km>	Spacecraft altitude from the Moon radius at the 1st line	
Spacecraft ground speed	SPACECRAFT_GROUND_SPEED = %6.3f <km/sec>	Spacecraft ground speed at the 1st line	
TC1 telescope temperature	TC1_TELESCOPE_TEMPERATURE = %6.2f <degC>	TC1 telescope temperature at the 1st line	
TC2 telescope temperature	TC2_TELESCOPE_TEMPERATURE = %6.2f <degC>	TC2 telescope temperature at the 1st line	
DPU temperature	DPU_TEMPERATURE = %6.2f <degC>	DPU temperature at the 1st line	
TM temperature	TM_TEMPERATURE = %6.2f <degC>	TM temperature at the 1st line	
TM radiator temperature	TM_RADIATOR_TEMPERATURE = %6.2f <degC>	TM radiator temperature at the 1st line	
Encoding type	ENCODING_TYPE = "%s"	Data encoding type	"DCT": DCT compression "N/A": non-compression
Encoding compression percentage	ENCODING_COMPRESSION_PERCENT = %5.1f	Compression percentage of the image data object	
Nominal line number	NOMINAL_LINE_NUMBER = %d	Nominal number of lines in this image	
Nominal sample number	NOMINAL_SAMPLE_NUMBER = %d	Nominal number of samples in a line	
Unfilled line number	UNFILLED_LINE_NUMBER = %d	Total number of lines with exceptional dummy samples due to insufficient compression	
Nominal overlapped line number	NOMINAL_OVERLAP_LINE_NUMBER = %d	Nominal number of overlapped lines	
Overlapped line number	OVERLAP_LINE_NUMBER = %d	Actual number of overlapped lines	
Lines	LINES = %d	Total number of lines in this image	
Line samples	LINE_SAMPLES = %d	Total number of pixels in a line of this image, including the number of dummy pixels	
Sample type	SAMPLE_TYPE = "%s"	Data storage representation of sample value	"N/A": compression data "MSB_UNSIGNED_INTEGER": non-compression data 12: compression data 16: non-compression data
Sample bits	SAMPLE_BITS = %d	Stored number of bits in a sample	
Minimum DN for statistical evaluation	MIN_FOR_STATISTICAL_EVALUATION = %d	Minimum DN for statistical evaluation	
Maximum DN for statistical evaluation	MAX_FOR_STATISTICAL_EVALUATION = %d	Maximum DN for statistical evaluation	
Scene maximum DN	SCENE_MAXIMUM_DN = %d	Maximum DN in this image	When the population of the image evaluation is 0, value is set to -1.
Scene minimum DN	SCENE_MINIMUM_DN = %d	Minimum DN in this image	When the population of the image evaluation is 0, value is set to -1.
Scene standard average DN	SCENE_AVERAGE_DN = %6.1f	Average DN in this image	When the population of the image evaluation is 0, value is set to -1.
Scene standard deviation DN	SCENE_STDEV_DN = %6.1f	Standard deviation DN in this image	When the population of the image evaluation is 0, value is set to -1.
Scene mode DN	SCENE_MODE_DN = %d	Mode DN in this image	When the population of the image evaluation is 0, value is set to -1.
Saturation threshold	SATURATION_THRESHOLD = %d	Threshold DN for saturated pixel detection	
Saturated pixels	SATURATED_PIXELS = %d	Total number of saturated pixels	When the population of the image evaluation is 0, value is set to -1.
Saturated pixel position	SATURATED_PIXEL_POSITION = (%d,%d), (%d,%d),...	Image coordinates of saturated pixels	When the total number of saturated pixels is 0, value is set to "N/A"
Saturated pixel percentage	SATURATED_PIXEL_PERCENTAGE = %d	Percentage of saturated pixels	When the population of the image evaluation is 0, value is set to -1.
Dead pixel threshold	DEAD_PIXEL_THRESHOLD = %d	Threshold DN for dead pixel detection	
Dead pixels	DEAD_PIXELS = %d	Total number of dead pixels	When the population of the image evaluation is 0, value is set to -1.
Dead pixel position	DEAD_PIXEL_POSITION = (%d,%d), (%d,%d),...	Image coordinates of dead pixels	
Dead pixel percentage	DEAD_PIXEL_PERCENTAGE = %d	Percentage of dead pixels	When the population of the image evaluation is 0, value is set to -1.
Shadowed area minimum	SHADOWED_AREA_MINIMUM = %d	Minimum DN for shadowed pixel detection	
Shadowed area maximum	SHADOWED_AREA_MAXIMUM = %d	Maximum DN for shadowed pixel detection	
Shadowed area percentage	SHADOWED_AREA_PERCENTAGE = %d	Percentage of shadowed pixels	When the population of the image evaluation is 0, value is set to -1.
	END_OBJECT = IMAGE		
	END_OBJECT = SOURCE_L2A_DATA_INFO		
	END		

Table 2.1-8 Items of PDS Label (Quality Flag File)

category	item name	description form	Explanation	Value
PDS label common items				
	PDS version ID	PDS_VERSION_ID = "%s"	PDS version ID	"PDS3" fixed
	File record type	RECORD_TYPE = "%s"	File record type	"UNDEFINED" fixed
	File name	FILE_NAME = "%s"	File name of this product (product ID + extension)	
	Product ID	PRODUCT_ID = "%s"	Unique ID given to every product	
	Data file format ID	DATA_FORMAT = "%s"	Data file format ID	"PDS" fixed
Object position specification				
	Head position of image object	^IMAGE = %10d <BYTES>	Head position of the image object	
Product information				
	File attributes			
	Software name	SOFTWARE_NAME = "%s"	Software name that created the DTM PDS product	TBD
	Software version	SOFTWARE_VERSION = "%s"	Software version that created the DTM PDS product	"n.n.n" (TBD)
	Processing level	PROCESS_VERSION_ID = "%s"	Processing level ID	"L3D": DTM/TC ortho, DTM mosaic and TC ortho mosaic "MAP": DTM map and TC ortho map
	Product creation time	PRODUCT_CREATION_TIME = %s	Product creation time	YYYY-MM-DDTHH:MM:SSZ
	Product attributes			
	Producer ID	PRODUCER_ID = "%s"	Data producer ID	"LISM" fixed
	Product set ID	PRODUCT_SET_ID = "%s"	Product set ID	"DTM_TCOrtho": DTM/TC ortho "DTM_MAP": DTM map "TCOrtho_MAP": TC ortho map "DTM_TCOrtho_S": DTM/TC ortho (special product) "DTM_MAP_S": DTM map (special product) "TCOrtho_MAP_S": TC ortho map (special product) "DTM_MSC": DTM mosaic (special product) "TCOrtho_MSC": TC ortho mosaic (special product)
	Product version ID	PRODUCT_VERSION_ID = "%s"	Product version ID	"01" to "99"
	Scene attributes			
	Mission name	MISSION_NAME = "%s"	Mission name	"SELENE" fixed
	Spacecraft name	SPACECRAFT_NAME = "%s"	Spacecraft name	"SELENE-M" fixed
	Data set ID	DATA_SET_ID = "%s"	This data set ID	TBD
	Instrument name	INSTRUMENT_NAME = "%s"	Full name of the instrument	"Terrain Camera"
	Instrument ID	INSTRUMENT_ID = "%s"	Instrument ID	"TC"
	Upper left latitude	UPPER_LEFT_LATITUDE = %10.6f <deg>	Latitude at center of the upper-left corner pixel of the image that contains dummy pixels	-90 to 90
	Upper left longitude	UPPER_LEFT_LONGITUDE = %10.6f <deg>	Longitude at center of the upper-left corner pixel of the image that contains dummy pixels	0 to 360
	Upper right latitude	UPPER_RIGHT_LATITUDE = %10.6f <deg>	Latitude at center of the upper-right corner pixel of the image that contains dummy pixels	-90 to 90
	Upper right longitude	UPPER_RIGHT_LONGITUDE = %10.6f <deg>	Longitude at center of the upper-right corner pixel of the image that contains dummy pixels	0 to 360
	Lower left latitude	LOWER_LEFT_LATITUDE = %10.6f <deg>	Latitude at center of the lower-left corner pixel of the image that contains dummy pixels	-90 to 90
	Lower left longitude	LOWER_LEFT_LONGITUDE = %10.6f <deg>	Longitude at center of the lower-left corner pixel of the image that contains dummy pixels	0 to 360
	Lower right latitude	LOWER_RIGHT_LATITUDE = %10.6f <deg>	Latitude at center of the lower-right corner pixel of the image that contains dummy pixels	-90 to 90
	Lower right longitude	LOWER_RIGHT_LONGITUDE = %10.6f <deg>	Longitude at center of the lower-right corner pixel of the image that contains dummy pixels	0 to 360
	Image center latitude	IMAGE_CENTER_LATITUDE = %10.6f <deg>	Latitude at the center pixel of the image	-90 to 90
	Image center longitude	IMAGE_CENTER_LONGITUDE = %10.6f <deg>	Longitude at the center pixel of the image	0 to 360
	Location flag	LOCATION_FLAG = "%s"	Spacecraft location information	"A": Ascending "D": Descending "N": When containing the imaging time which changes from the ascending to the descending "S": When containing the imaging time which changes from the descending to the ascending
Distance between the moon and the sun	MOON_SUN_DISTANCE = %d <km>	Distance between the Moon and the Sun		
Map projection information				
	Map projection	OBJECT = IMAGE_MAP_PROJECTION MAP_PROJECTION_TYPE = "%s"	Name of the map projection	"Simple Cylindrical", "Stereographic", "Lambert Conformal" or "Transverse Mercator"
	Coordinate system type	COORDINATE_SYSTEM_TYPE = "%s"	Type of the coordinate system	"BODY-FIXED ROTATING" fixed
	Coordinate system name	COORDINATE_SYSTEM_NAME = "%s"	Full name of the coordinate system	"PLANETOCENTRIC" fixed
	A axis radius	A_AXIS_RADIUS = %8.3f <km>	A axis radius of the Moon	1737.4 <KM> default
	B axis radius	B_AXIS_RADIUS = %8.3f <km>	B axis radius of the Moon	1737.4 <KM> default
	C axis radius	C_AXIS_RADIUS = %8.3f <km>	C axis radius of the Moon	1737.4 <KM> default
	First standard parallel	FIRST_STANDARD_PARALLEL = %10.6f <deg>	First standard parallel Used for "Lambert Conformal" projection.	-90 to 90 for "Lambert Conformal" projection "N/A" for other map projection
	Second standard parallel	SECOND_STANDARD_PARALLEL = %10.6f <deg>	Second standard parallel Used for "Lambert Conformal" projection.	-90 to 90 for "Lambert Conformal" projection "N/A" for other map projection
	Positive longitude direction	POSITIVE_LONGITUDE_DIRECTION = "%s"	Positive direction of longitude	"EAST" fixed
	Center latitude	CENTER_LATITUDE = %10.6f <deg>	Latitude at the origin in a given MAP_PROJECTION_TYPE	-90 to 90
	Center longitude	CENTER_LONGITUDE = %10.6f <deg>	Longitude at the origin in a given MAP_PROJECTION_TYPE	0 to 360
	Reference latitude	REFERENCE_LATITUDE = %10.6f <deg>	Zero latitude in a rotated spherical coordinate system that was used in a given MAP_PROJECTION_TYPE	"N/A" fixed
	Reference longitude	REFERENCE_LONGITUDE = %10.6f <deg>	Zero longitude in a rotated spherical coordinate system that was used in a given MAP_PROJECTION_TYPE	"N/A" fixed
	First line number	LINE_FIRST_PIXEL = %d	Line number of the upper end pixel of the image	1 fixed
	Last line number	LINE_LAST_PIXEL = %d	Line number of the lower end pixel of the image	
	First sample number	SAMPLE_FIRST_PIXEL = %d	Sample number of the left end pixel of the image	1 fixed
	Last sample number	SAMPLE_LAST_PIXEL = %d	Sample number of the right end pixel of the image	
	Map orientation angle	MAP_PROJECTION_ROTATION = %f <deg>	Clockwise rotation of the line and sample coordinates with respect to the map projection origin	0.0 fixed
	Map resolution	MAP_RESOLUTION = %f <pixel/deg>	Total number of pixels in a box area of 1-degree latitude x 1-degree longitude for	"N/A" is given when MAP_PROJECTION_TYPE is not

			Simple Cylindrical Projection	"Simple Cylindrical".
	Map scale	MAP_SCALE = %f <km/pixel>	Actual distance, in km, between two points at the origin in a given MAP_PROJECTION_TYPE	
	Maximum latitude	MAXIMUM_LATITUDE = %10.6f <deg>	Latitude at the center of the northernmost pixel in 4 corner pixels	-90 to 90
	Minimum latitude	MINIMUM_LATITUDE = %10.6f <deg>	Latitude at the center of the southernmost pixel in 4 corner pixels	-90 to 90
	Easternmost longitude	EASTERMOST_LONGITUDE = %10.6f <deg>	Longitude at the center of the easternmost pixel in 4 corner pixels	0 to 360
	Westernmost longitude	WESTERMOST_LONGITUDE = %10.6f <deg>	Longitude at the center of the westernmost pixel in 4 corner pixels	0 to 360
	Line projection offset	LINE_PROJECTION_OFFSET = %f	Map projection coordinates, in pixels, at the center of the upper-left corner pixel of this image	
	Sample projection offset	SAMPLE_PROJECTION_OFFSET = %f	Map projection coordinates, in pixels, at the center of the upper-left corner pixel of this image	
	Resampling method	RESAMPLING_METHOD = "%s"	Image resampling method	"Nearest Neighbor", "Bi-linear", "Cubic Convolution" or "Logical Sum"
		END_OBJECT = IMAGE_MAP_PROJECTION		
Processing parameter description				
		OBJECT = PROCESSING_PARAMETERS		
	Parameter set name	PARAMETER_SET_NAME = "%s"	Name of processing parameter set	TBD
		END_OBJECT = PROCESSING_PARAMETERS		
Image information				
		OBJECT = IMAGE		
	Bands	BANDS = %d	Total number of bands in this image	1 fixed
	Band storage type	BAND_STORAGE_TYPE = "%s"	Storage sequence of lines, samples, and bands in this image	"BAND_SEQUENTIAL" fixed
	Band name	BAND_NAME = "%s"	Spectral range(s) associated with each band in single-band or multi-band data	"N/A" fixed
	Lines	LINES = %d	Total number of lines in this image	
	Line samples	LINE_SAMPLES = %d	Total number of pixels in a line	
	Sample type	SAMPLE_TYPE = "%s"	Image data type	"MSB_INTEGER" (DTM) or "MSB_UNSIGNED_INTEGER" (TC ortho)
	Sample bits	SAMPLE_BITS = %d	Total number of bits used to store one data sample value	8 or 16
	Sample bit mask	SAMPLE_BIT_MASK = %s	Active bits in a sample	2811111111111111#; 8 bits 281111111111111111#; 16 bits
		END_OBJECT = IMAGE		
Quality information				
		OBJECT = QUALITY_INFO		
	Quality bit mask information	QA_BIT_MASK_INFO = {(%s,"%s"),(%s,"%s"),...}	Information of bit mask of the quality flag file	{(2#00000001#,"DEFECT PIXEL"), (2#00000010#,"SATURATED PIXEL"), (2#00010000#,"SHADOW PIXEL"), (2#00100000#,"BAD PIXEL"), (2#01000000#,"DUMMY PIXEL"), (2#10000000#,"INTERPOLATED PIXEL")}
	Good pixel percentage	QA_PERCENT_GOOD_PIXEL = %f	Percentage of good pixels in all the DTM pixels	The total number of QA_PERCENT_GOOD_PIXEL, QA_PERCENT_DUMMY_PIXEL and QA_PERCENT_BAD_PIXEL is 100.0
	Dummy pixel percentage	QA_PERCENT_DUMMY_PIXEL = %f	Percentage of dummy pixels in all the DTM pixels	
	Bad pixel percentage	QA_PERCENT_BAD_PIXEL = %f	Percentage of bad pixels in all the DTM pixels	
	Interpolated pixel percentage	QA_PERCENT_INTERPOLATED_PIXEL = %f	Percentage of interpolated pixels in all the DTM pixels	
	Shadow pixel percentage	QA_PERCENT_SHADOW_PIXEL = %f	Percentage of shadowed pixels in all the DTM pixels	
	Correlation threshold of bad pixel	BAD_PIXEL_THRESHOLD_CORRELATION = %f	Threshold of image correlation between stereo images to extract the bad pixel from the DTM	
	Slope threshold of bad pixel	BAD_PIXEL_THRESHOLD_SLOPE = %f <deg>	Slope angle threshold to extract the bad pixel from the DTM	
		END_OBJECT = QUALITY_INFO		
		END		

Table 2.1-9 Items of PDS Label (TC Ortho File)

Category	Item	Description form	Explanation	Value
PDS label common items				
	PDS version ID	PDS_VERSION_ID = "%s"	PDS version ID	"PDS3" fixed
	File record type	RECORD_TYPE = "%s"	File record type	"UNDEFINED" fixed
	File name	FILE_NAME = "%s"	File name of this product (product ID + extension)	
	Product ID	PRODUCT_ID = "%s"	Unique ID given to every product	
	Data file format ID	DATA_FORMAT = "%s"	Data file format ID	"PDS" fixed
Object position specification				
	Head position of image object	^IMAGE = %10d <BYTES>	Head position of the image object	
Product information				
	File attributes			
	Software name	SOFTWARE_NAME = "%s"	Name of software that created the DTM PDS product	TBD
	Software version	SOFTWARE_VERSION = "%s"	Version of software that created the DTM PDS product	"n.n.n" (TBD)
	Processing level	PROCESS_VERSION_ID = "%s"	Processing level ID	"L3D": DTM/TC ortho, DTM mosaic and TC ortho mosaic "MAP": DTM map and TC ortho map
	Product creation time	PRODUCT_CREATION_TIME = %s	Product creation time	YYYY-MM-DDTHH:MM:SSZ
	Product attributes			
	Producer ID	PRODUCER_ID = "%s"	Data producer ID	"LISM" fixed
	Product set ID	PRODUCT_SET_ID = "%s"	Product set ID	"DTM_TCOrtho": DTM/TC ortho "DTM_MAP": DTM map "TCOrtho_MAP": TC ortho map "DTM_TCOrtho_S": DTM/TC ortho (special product) "DTM_MAP_S": DTM map (special product) "TCOrtho_MAP_S": TC ortho map (special product) "DTM_MSC": DTM mosaic (special product) "TCOrtho_MSC": TC ortho mosaic (special product)
	Product version ID	PRODUCT_VERSION_ID = "%s"	Product version ID	"01" - "99"
	Base L2A data file name	BASE_LEVEL2A_FILE_NAME = "%s"	L2A data file name of the base image used for creating DTM	
	Reference L2A data file name	REFERENCE_LEVEL2A_FILE_NAME = {"%s", "%s", ...}	L2A data file names of all reference images were used for creating DTM	
	SPICE kernel file name (SPK)	SPICE_SPK_FILE_NAME = {"%s", "%s", ...}	All SPICE kernel (SPK) names used for creating DTM/ortho product	
	SPICE kernel file name (PK)	SPICE_PCK_FILE_NAME = {"%s", "%s", ...}	All SPICE kernel (PK) names used for creating DTM/ortho product	
	SPICE kernel file name (IK)	SPICE_IK_FILE_NAME = {"%s", "%s", ...}	All SPICE kernel (IK) names used for creating DTM/ortho product	
	SPICE kernel file name (CK)	SPICE_CK_FILE_NAME = {"%s", "%s", ...}	All SPICE kernel (CK) names used for creating DTM/ortho product	
	SPICE kernel file name (SCLK)	SPICE_SCLK_FILE_NAME = {"%s", "%s", ...}	All SPICE kernel (SCLK) names used for creating DTM/ortho product	
	SPICE kernel file name (LSK)	SPICE_LSK_FILE_NAME = {"%s", "%s", ...}	All SPICE kernel (LSK) names used for creating DTM/ortho product	
	Scene attributes			
	Mission name	MISSION_NAME = "%s"	Mission name	"SELENE" fixed
	Spacecraft name	SPACECRAFT_NAME = "%s"	Spacecraft name	"SELENE-M" fixed
	Data set ID	DATA_SET_ID = "%s"	This data set ID	TBD
	Instrument name	INSTRUMENT_NAME = "%s"	Full name of instrument	"Terrain Camera"
	Instrument ID	INSTRUMENT_ID = "%s"	Instrument ID	"TC"
	Upper left latitude	UPPER_LEFT_LATITUDE = %10.6f <deg>	Latitude at the center of the upper-left corner pixel of the image that contains dummy pixels	-90 to 90
	Upper left longitude	UPPER_LEFT_LONGITUDE = %10.6f <deg>	Longitude at the center of the upper-left corner pixel of the image that contains dummy pixels	0 to 360
	Upper right latitude	UPPER_RIGHT_LATITUDE = %10.6f <deg>	Latitude at the center of the upper-right corner pixel of the image that contains dummy pixels	-90 to 90
	Upper right longitude	UPPER_RIGHT_LONGITUDE = %10.6f <deg>	Longitude at the center of the upper-right corner pixel of the image that contains dummy pixels	0 to 360
	Lower left latitude	LOWER_LEFT_LATITUDE = %10.6f <deg>	Latitude at the center of the lower-left corner pixel of the image that contains dummy pixels	-90 to 90
	Lower left longitude	LOWER_LEFT_LONGITUDE = %10.6f <deg>	Longitude at the center of the lower-left corner pixel of the image that contains dummy pixels	0 to 360
	Lower right latitude	LOWER_RIGHT_LATITUDE = %10.6f <deg>	Latitude at the center of the lower-right corner pixel of the image that contains dummy pixels	-90 to 90
	Lower right longitude	LOWER_RIGHT_LONGITUDE = %10.6f <deg>	Longitude at the center of the lower-right corner pixel of the image that contains dummy pixels	0 to 360
	Image center latitude	IMAGE_CENTER_LATITUDE = %10.6f <deg>	Latitude at the center pixel of the image	-90 to 90
	Image center longitude	IMAGE_CENTER_LONGITUDE = %10.6f <deg>	Longitude at the center pixel of the image	0 to 360
	Location flag	LOCATION_FLAG = "%s"	Spacecraft location information	"A": Ascending "D": Descending "N": When containing the imaging time which changes from the ascending to the descending "S": When containing the imaging time which changes from the descending to the ascending
	Distance between the Moon and the Sun	MOON_SUN_DISTANCE = %d <km>	Distance between the Moon and the Sun	
Map projection information				
	Map projection	MAP_PROJECTION_TYPE = "%s"	Map projection	"Simple Cylindrical", "Stereographic", "Lambert Conformal" or "Transverse Mercator"
	Coordinate system type	COORDINATE_SYSTEM_TYPE = "%s"	Type of the coordinate system	"BODY-FIXED ROTATING" fixed
	Coordinate system name	COORDINATE_SYSTEM_NAME = "%s"	Full name of the coordinate system	"PLANETOCENTRIC" fixed
	A axis radius	A_AXIS_RADIUS = %8.3f <km>	A axis radius of the Moon	1737.4 <KM> default
	B axis radius	B_AXIS_RADIUS = %8.3f <km>	B axis radius of the Moon	1737.4 <KM> default
	C axis radius	C_AXIS_RADIUS = %8.3f <km>	C axis radius of the Moon	1737.4 <KM> default
	First standard parallel	FIRST_STANDARD_PARALLEL = %10.6f <deg>	First standard parallel Used for "Lambert Conformal" projection	-90 to 90 for "Lambert Conformal" projection "N/A" for other map projections
	Second standard parallel	SECOND_STANDARD_PARALLEL = %10.6f <deg>	Second standard parallel Used for "Lambert Conformal" projection	-90 to 90 for "Lambert Conformal" projection "N/A" for other map projections
	Positive longitude direction	POSITIVE_LONGITUDE_DIRECTION = "%s"	Positive longitude direction	"EAST" fixed

Center latitude	CENTER_LATITUDE = %10.6f <deg>	Latitude at the origin in a given MAP_PROJECTION_TYPE	-90 to 90
Center longitude	CENTER_LONGITUDE = %10.6f <deg>	Longitude at the origin in a given MAP_PROJECTION_TYPE	0 to 360
Reference latitude	REFERENCE_LATITUDE = %10.6f <deg>	Zero latitude in a rotated spherical coordinate system that was used in a given MAP_PROJECTION_TYPE	"N/A" fixed
Reference longitude	REFERENCE_LONGITUDE = %10.6f <deg>	Zero longitude in a rotated spherical coordinate system that was used in a given MAP_PROJECTION_TYPE	"N/A" fixed
First line number	LINE_FIRST_PIXEL = %d	Line number of the upper end pixel of the image	1 fixed
Last line number	LINE_LAST_PIXEL = %d	Line number of the lower end pixel of the image	
First sample number	SAMPLE_FIRST_PIXEL = %d	Sample number of the left end pixel of the image	1 fixed
Last sample number	SAMPLE_LAST_PIXEL = %d	Sample number of the right end pixel of the image	
Map orientation angle	MAP_PROJECTION_ROTATION = %f <deg>	Clockwise rotation of the line and sample coordinates with respect to the map projection origin	0.0 fixed
Map resolution	MAP_RESOLUTION = %f <pixel/deg>	Total number of pixels in a box area of 1-degree latitude x 1-degree longitude for Simple Cylindrical Projection	"N/A" is given when MAP_PROJECTION_TYPE is not "Simple Cylindrical."
Map scale	MAP_SCALE = %f <km/pixel>	Actual distance, in km, between two points at the origin in a given MAP_PROJECTION_TYPE	
Maximum latitude	MAXIMUM_LATITUDE = %10.6f <deg>	Latitude at the center of the northernmost pixel in 4 corner pixels	-90 to 90
Minimum latitude	MINIMUM_LATITUDE = %10.6f <deg>	Latitude at the center of the southernmost pixel in 4 corner pixels	-90 to 90
Easternmost longitude	EASTERMOST_LONGITUDE = %10.6f <deg>	Longitude at the center of the easternmost pixel in 4 corner pixels	0 to 360
Westernmost longitude	WESTERNMOST_LONGITUDE = %10.6f <deg>	Longitude at the center of the westernmost pixel in 4 corner pixels	0 to 360
Line projection offset	LINE_PROJECTION_OFFSET = %f	Map projection coordinates, in pixels, at the center of the upper-left corner pixel of this image	
Sample projection offset	SAMPLE_PROJECTION_OFFSET = %f	Map projection coordinates, in pixels, at the center of the upper-left corner pixel of this image	
Resampling method	RESAMPLING_METHOD = "%s"	Image resampling method	"Nearest Neighbor", "Bilinear", "Cubic Convolution" or "Logical Sum"
	END_OBJECT = IMAGE_MAP_PROJECTION		
Processing parameter description			
	OBJECT = PROCESSING_PARAMETERS		
Parameter set name	PARAMETER_SET_NAME = "%s"	Name of the processing parameter set	TBD
Dark file name	DARK_FILE_NAME = "%s"	Dark current correction coefficient file name	
Flat file name	FLAT_FILE_NAME = "%s"	Flat field correction coefficient file name	
Efficiency file name	EFFIC_FILE_NAME = "%s"	Coefficient file name of temperature dependency correction of transmittance efficiency	
Non-linearity file name	NONLIN_FILE_NAME = "%s"	File name of non-linearity correction coefficient	
Radiance conversion coefficient	RAD_CNV_COEF = %f	Radiance conversion coefficient [W/m ² /micron/sr]	
	END_OBJECT = PROCESSING_PARAMETERS		
Image information			
	OBJECT = IMAGE		
Bands	BANDS = %d	Total number of bands in this image	1 fixed
Band storage type	BAND_STORAGE_TYPE = "%s"	Storage sequence of lines, samples, and bands in this image	"BAND_SEQUENTIAL" fixed
Band name	BAND_NAME = "%s"	Spectral range(s) associated with each band in single-band or multi-band data	"N/A" fixed
Lines	LINES = %d	Total number of lines in this image	
Line samples	LINE_SAMPLES = %d	Total number of pixels in a line	
Sample type	SAMPLE_TYPE = "%s"	Image data type	"MSB_INTEGER" (DTM) or "MSB_UNSIGNED_INTEGER" (TC ortho)
Sample bits	SAMPLE_BITS = %d	Total number of bits used to store one data sample value	8 or 16
Meaning of pixel value	IMAGE_VALUE_TYPE = "%s"	Meaning of the value of the pixel	"DN", "RADIANCE", "REFLECTANCE", or "ELEVATION"
Sample bit mask	SAMPLE_BIT_MASK = %s	Active bits in a sample	2#11111111#; 8 bits 2#1111111111111111#; 16 bits
Offset	OFFSET = %f	Offset value used in the DN for physical quantity conversion DTM and DTM map: Elevation = DN*SCALING_FACTOR-OFFSET Unit is "meters" from the Moon radius. TC ortho and TC ortho map (REF_CNV_SW="OFF"): Radiance = DN*SCALING_FACTOR-OFFSET Unit is "w/m ² /μ m/sr" TC ortho map (REF_CNV_SW="ON"): Reflectivity = DN*SCALING_FACTOR-OFFSET Unit is "%"	
Scaling factor	SCALING_FACTOR = %f	Gain used in the DN for physical quantity conversion	
Stretched flag	STRETCHED_FLAG = "%s"	Whether a data object has been stretched to make it easy to see	"FALSE" fixed
Valid minimum	VALID_MINIMUM = %d	Minimum value that is valid for a data object	-9899: DTM 2: TC ortho
Valid maximum	VALID_MAXIMUM = %d	Maximum value that is valid for a data object	32766 fixed
Dummy	DUMMY = %d	Indicates the dummy (blank) pixel of the image	-9999: DTM 0: TC ortho
Low saturation (REPR)	LOW_REPR_SATURATION = %d	Indicates the minimum saturation pixel after radiometric correction	1 fixed
Low saturation (INSTR)	LOW_INSTR_SATURATION = %d	Indicates the minimum saturation pixel at instrument measurement	1 fixed
High saturation (REPR)	HIGH_REPR_SATURATION = %d	Indicates the maximum saturation pixel after radiometric correction	32767 fixed
High saturation (INSTR)	HIGH_INSTR_SATURATION = %d	Indicates the maximum saturation pixel at instrument measurement	32767 fixed
Minimum	MINIMUM = %d	Minimum value in this image except the invalid pixels	When the total number of valid pixels is 0, the value of DTM is set to -9999 and the value of the TC ortho is set to -1.
Maximum	MAXIMUM = %d	Maximum value in this image except the invalid pixels	When the total number of valid pixels is 0, the value of DTM is set to -9999 and the value of the TC ortho is set to -1.
Average	AVERAGE = %f	Average value in this image except the invalid pixels	When the total number of valid pixels is 0, the value of DTM is set to -9999 and the value of the TC

	Standard deviation	STDEV = %f	Standard deviation in this image except the invalid pixels	ortho is set to -1. When the total number of valid pixels is 0, the value of DTM is set to -9999 and the value of the TC ortho is set to -1.
	Mode pixel	MODE_PIXEL = %d	Mode in this image except the invalid pixels	When the total number of valid pixels is 0, the value of DTM is set to -9999 and the value of the TC ortho is set to -1.
		END_OBJECT = IMAGE		
Base L2A source data information				
		OBJECT = SOURCE_L2A_DATA_INFO		
	L2A file name	FILE_NAME = "%s"	File name of the L2A product	
	L2A creation time	PRODUCT_CREATION_TIME = %s	L2A product data creation time	YYYY-MM-DDTHH:MM:SSZ
	Execution count	EXECUTION_COUNT = %d	Execution count of the L2A product	
	Illumination condition	ILLUMINATION_CONDITION = "%s"	Illumination condition	"MORNING" or "EVENING"
	L0 file name	LEVEL0_FILE_NAME = {"%s", "%s", ...}	File names of all the L0 data used for creating L2A	
	Spacecraft time correction file name	SC_TIME_CORRECTION_FILE_NAME = {"%s", "%s", ...}	File names of all the spacecraft time correction files used for creating L2A	
	Orbit data file name	ORBIT_DATA_FILE_NAME = {"%s", "%s", ...}	File names of all the orbit data files used for creating L2A	
	Attitude data file name	ATTITUDE_DATA_FILE_NAME = {"%s", "%s", ...}	File names of all the attitude data files used for creating L2A	
	Revolution number file name	REVOLUTION_NUMBER_FILE_NAME = {"%s", "%s", ...}	File names of all the revolution number files used for creating L2A	
	HK mission file name	HK_MISSION_FILE_NAME = {"%s", "%s", ...}	File names of all the mission instrument HK files used for creating L2A	
	SPICE kernel (SPK) file name	SPICE_SPK_FILE_NAME = {"%s", "%s", ...}	File names of all the SPICE kernel (SPK) files used for creating L2A	
	SPICE kernel (PCK) file name	SPICE_PCK_FILE_NAME = {"%s", "%s", ...}	File names of all the SPICE kernel (PCK) files used for creating L2A	
	SPICE kernel (IK) file name	SPICE_IK_FILE_NAME = {"%s", "%s", ...}	File names of all the SPICE kernel (IK) files used for creating L2A	
	SPICE kernel (CK) file name	SPICE_CK_FILE_NAME = {"%s", "%s", ...}	File names of all the SPICE kernel (CK) files used for creating L2A	
	SPICE kernel (SCLK) file name	SPICE_SCLK_FILE_NAME = {"%s", "%s", ...}	File names of all the SPICE kernel (SCLK) files used for creating L2A	
	SPICE kernel (LSK) file name	SPICE_LSK_FILE_NAME = {"%s", "%s", ...}	File names of all the SPICE kernel (LSK) files used for L2A creating	
	Scene definition file name	SCENE_DEFINITION_FILE_NAME = "%s"	File name of the scene definition file used for creating L2A	
	Threshold file name	THRESHOLD_FILE_NAME = "%s"	Threshold file name	
	Conversion table file name	CONVERSION_TABLE_FILE_NAME = "%s"	Engineering value translated for table file	
	Instrument name	INSTRUMENT_NAME = "%s"	Full name of the instrument	"Terrain Camera 1" or "Terrain Camera 2"
	Instrument ID	INSTRUMENT_ID = "%s"	Instrument ID	"TC1" or "TC2"
	Revolution number	REVOLUTION_NUMBER = %d	Revolution number	
	Strip sequence number	STRIP_SEQUENCE_NUMBER = %d	Strip number in the revolution	
	Scene sequence number	SCENE_SEQUENCE_NUMBER = %d	Scene number in the strip	
	Mission phase name	MISSION_PHASE_NAME = "%s"	Mission phase name	"Nominal", "Option", etc.
	Upper left daytime flag	UPPER_LEFT_DAYTIME_FLAG = "%s"	Sunshine condition at the upper left pixel and the upper right pixel of the image	"Day" or "Night"
	Upper right daytime flag	UPPER_RIGHT_DAYTIME_FLAG = "%s"		
	Lower left daytime flag	LOWER_LEFT_DAYTIME_FLAG = "%s"	Sunshine condition at the lower left pixel and the lower right pixel of the image	"Day" or "Night"
	Lower right daytime flag	LOWER_RIGHT_DAYTIME_FLAG = "%s"		
	Target name	TARGET_NAME = "%s"	Observation target name of this strip	"MOON" default
	Observation mode ID	OBSERVATION_MODE_ID = "%s"	Observation mode ID	"NORMAL" or "SUPPORT"
	Sensor Description	SENSOR_DESCRIPTION = "%s"	Sensor specifications	
	Sensor Description2	SENSOR_DESCRIPTION2 = "%s"	Spare sensor information	
	Detector status	DETECTOR_STATUS {"TC1:%s", "TC2:%s", "MV:%s", "MN:%s", "SP:%s"} =	ON/OFF of each of 5 power (TC1, TC2, MI-VIS, MI-NIR, SP) in this scene center	
	Exposure mode ID	EXPOSURE_MODE_ID = "%s"	Exposure mode ID	"LONG", "MIDDLE", "SHORT"
	Spacecraft clock start count (TI)	SPACECRAFT_CLOCK_START_COUNT = %15.4f <sec>	Spacecraft clock count at the 1st line (TI)	
	Spacecraft clock stop count (TI)	SPACECRAFT_CLOCK_STOP_COUNT = %15.4f <sec>	Spacecraft clock count at the last line (TI)	
	Corrected spacecraft clock start count (TI)	CORRECTED_SC_CLOCK_START_COUNT = %17.6f <sec>	Corrected spacecraft clock count at the 1st line (TI)	
	Corrected spacecraft clock stop count (TI)	CORRECTED_SC_CLOCK_STOP_COUNT = %17.6f <sec>	Corrected spacecraft clock count at the last line (TI)	
	Start time (UT)	START_TIME = %s	Imaging time at the 1st line (UT)	YYYY-MM-DDTHH:MM:SS.sssssZ
	Stop time (UT)	STOP_TIME = %s	Imaging time at the last line (UT)	YYYY-MM-DDTHH:MM:SS.sssssZ
	Corrected start time (UT)	CORRECTED_START_TIME = %s	Corrected imaging time at the 1st line (UT)	YYYY-MM-DDTHH:MM:SS.sssssZ
	Corrected stop time (UT)	CORRECTED_STOP_TIME = %s	Corrected imaging time at the last line (UT)	YYYY-MM-DDTHH:MM:SS.sssssZ
	Location flag	LOCATION_FLAG = "%s"	Spacecraft location information	"A": Ascending "D": Descending "N": When containing the imaging time which changes from the ascending to the descending "S": When containing the imaging time which changes from the descending to the ascending "YES": roll-cant observation "NO": nadir-view observation
	Roll cant	ROLL_CANT = "%s"	Selection of nadir-view observation or roll-cant observation	
	Incidence angle	INCIDENCE_ANGLE = %7.3f <deg>	Incidence angle at the scene center	
	Emission angle	EMISSION_ANGLE = %7.3f <deg>	Emission angle at the scene center	
	Phase angle	PHASE_ANGLE = %7.3f <deg>	Phase angle at the scene center	
	Solar azimuth angle	SOLAR_AZIMUTH_ANGLE = %7.3f <deg>	Solar azimuth angle at the scene center	
	Focal plane temperature	FOCAL_PLANE_TEMPERATURE = %6.2f <degC>	Detector temperature at the 1st line	
	Telescope temperature	TELESCOPE_TEMPERATURE = %6.2f <degC>	Telescope temperature at the 1st line	
	Line exposure duration	LINE_EXPOSURE_DURATION = %10.6f <msec>	Line exposure duration	
	Line sampling interval	LINE_SAMPLING_INTERVAL = %10.6f <msec>	Designed value of sampling interval	
	Corrected sampling interval	CORRECTED_SAMPLING_INTERVAL = %10.6f <msec>	Sampling interval corrected by dividing the corrected interval time between the first line and the last line of the strip into the number of lines	
	Satellite moving direction	SATELLITE_MOVING_DIRECTION = "%s"	Direction of satellite travel	"-1": lead of -x plane "-1": lead of -x plane
	Qtable ID	Q_TABLE_ID = "%s"	Qtable ID	
	Huffman table ID	HUFFMAN_TABLE_ID = "%s"	Huffman table ID	
	Data compression percentage mean	DATA_COMPRESSION_PERCENT_MEAN = %5.1f	Mean of compression percentage in the scene	

Data compression percentage maximum	DATA_COMPRESSION_PERCENT_MAX = %5.1f	Maximum of compression percentage in the scene	
Data compression percentage minimum	DATA_COMPRESSION_PERCENT_MIN = %5.1f	Minimum of compression percentage in the scene	
Defect pixel position	DEFECT_PIXEL_POSITION = (%d,%d,...)	Detector number of the defect pixels	
Constant dummy pixels	CONSTANT_DUMMY_PIXELS = %d	Total number of dummy pixels for the compression	
Swath mode ID	SWATH_MODE_ID = "%s"	Name of the swath mode	"NOMINAL", "FULL" or "HALF"
First pixel number	FIRST_PIXEL_NUMBER = %d	Detector number of the first sample pixel	
Last pixel number	LAST_PIXEL_NUMBER = %d	Detector number of the last sample pixel	
Spacecraft altitude	SPACECRAFT_ALTITUDE = %8.3f <km>	Spacecraft altitude from the Moon radius at the 1st line	
Spacecraft ground speed	SPACECRAFT_GROUND_SPEED = %6.2f <km/sec>	Spacecraft ground speed at the 1st line	
TC1 telescope temperature	TC1_TELESCOPE_TEMPERATURE = %6.2f <degC>	TC1 telescope temperature at the 1st line	
TC2 telescope temperature	TC2_TELESCOPE_TEMPERATURE = %6.2f <degC>	TC2 telescope temperature at the 1st line	
DPU temperature	DPU_TEMPERATURE = %6.2f <degC>	DPU temperature at the 1st line	
TM temperature	TM_TEMPERATURE = %6.2f <degC>	TM temperature at the 1st line	
TM radiator temperature	TM_RADIATOR_TEMPERATURE = %6.2f <degC>	TM radiator temperature at the 1st line	
Encoding type	OBJECT = IMAGE ENCODING_TYPE = "%s"	Data encoding type	"DCT": DCT compression "N/A": non-compression
Encoding compression percentage	ENCODING_COMPRESSION_PERCENT = %5.1f	Compression percentage of the image data object	
Nominal line number	NOMINAL_LINE_NUMBER = %d	Nominal number of lines in this image	
Nominal sample number	NOMINAL_SAMPLE_NUMBER = %d	Nominal number of samples in a line	
Unfilled line number	UNFILLED_LINE_NUMBER = %d	Total number of lines with exceptional dummy samples due to insufficient compression	
Nominal overlapped line number	NOMINAL_OVERLAP_LINE_NUMBER = %d	Nominal number of overlapped lines	
Overlapped line number	OVERLAP_LINE_NUMBER = %d	Actual number of overlapped lines	
Lines	LINE_SAMPLES = %d	Total number of lines in this image	
Line samples	LINE_SAMPLES = %d	Total number of pixels in a line of this image, including the number of dummy pixels	
Sample type	SAMPLE_TYPE = "%s"	Data storage representation of sample value	"N/A": compression data "MSB_UNSIGNED_INTEGER": non-compression data
Sample bits	SAMPLE_BITS = %d	Stored number of bits in a sample	12: compression data 16: non-compression data
Minimum DN for statistical evaluation	MIN_FOR_STATISTICAL_EVALUATION = %d	Minimum DN for statistical evaluation	
Maximum DN for statistical evaluation	MAX_FOR_STATISTICAL_EVALUATION = %d	Maximum DN for statistical evaluation	
Scene maximum DN	SCENE_MAXIMUM_DN = %d	Maximum DN in this image	When the population of the image evaluation is 0, value is set to -1.
Scene minimum DN	SCENE_MINIMUM_DN = %d	Minimum DN in this image	When the population of the image evaluation is 0, value is set to -1.
Scene standard average DN	SCENE_AVERAGE_DN = %6.1f	Average DN in this image	When the population of the image evaluation is 0, value is set to -1.
Scene standard deviation DN	SCENE_STDEV_DN = %6.1f	Standard deviation DN in this image	When the population of the image evaluation is 0, value is set to -1.
Scene mode DN	SCENE_MODE_DN = %d	Mode DN in this image	When the population of the image evaluation is 0, value is set to -1.
Saturation threshold	SATURATION_THRESHOLD = %d	Threshold DN for saturated pixel detection	
Saturated pixels	SATURATED_PIXELS = %d	Total number of saturated pixels	When the population of the image evaluation is 0, value is set to -1.
Saturated pixel position	SATURATED_PIXEL_POSITION = ((%d,%d), (%d,%d),...)	Image coordinates of saturated pixels	When the total number of saturated pixel is 0, value is set to "N/A".
Saturated pixel percentage	SATURATED_PIXEL_PERCENTAGE = %d	Percentage of saturated pixels	When the population of the image evaluation is 0, value is set to -1.
Dead pixel threshold	DEAD_PIXEL_THRESHOLD = %d	Threshold DN for dead pixel detection	
Dead pixels	DEAD_PIXELS = %d	Total number of dead pixels	When the population of the image evaluation is 0, value is set to -1.
Dead pixel position	DEAD_PIXEL_POSITION = ((%d,%d), (%d,%d),...)	Image coordinates of dead pixels	
Dead pixel percentage	DEAD_PIXEL_PERCENTAGE = %d	Percentage of dead pixels	When the population of the image evaluation is 0, value is set to -1.
Shadowed area minimum	SHADOWED_AREA_MINIMUM = %d	Minimum DN for shadowed pixel detection	
Shadowed area maximum	SHADOWED_AREA_MAXIMUM = %d	Maximum DN for shadowed pixel detection	
Shadowed area percentage	SHADOWED_AREA_PERCENTAGE = %d	Percentage of shadowed pixels	When the population of the image evaluation is 0, value is set to -1.
	END_OBJECT = IMAGE		
	END_OBJECT = SOURCE_L2A_DATA_INFO		
	END		

(2) Image Data Object

The format of the Image Data Object of each image file (DTM, Quality Flag, or TC Ortho) is given in Table 2.1-10.

Table 2.1-10 Format of the Image Data Object

Image File	Bit Length	Format	Endian	Value
DTM	16	signed short integer	big endian	
Quality Flag	8	unsigned char	-	Bitflag 00000001: detector deficit 00000010: saturated 00000100: not used 00001000: not used 00010000: shadow 00100000: DTM error 01000000: dummy 10000000: interpolated
TC Ortho	16	unsigned short integer	big endian	

2.2 DTM Map

The DTM Map is a data set of mosaicked scene DTM data. It is a Tar archive composed of the following four files.

- Catalog Information File
- PDS Product File
- Low-Resolution File
- Thumbnail File

Figure 2.2-1 illustrates the configuration of the DTM Map File, and Fig. 2.2-2 presents the configuration of the DTM Map PDS Product File.

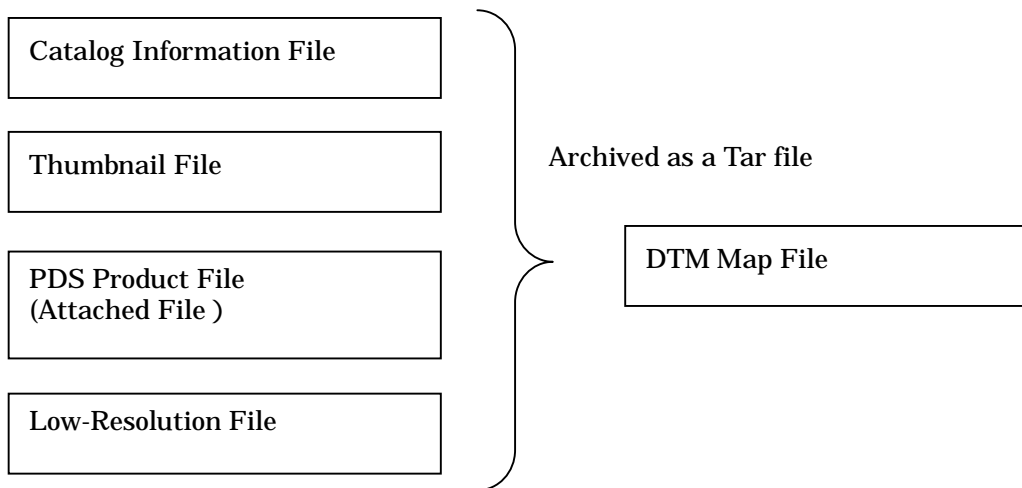

Fig. 2.2-1 Configuration of the DTM Map File

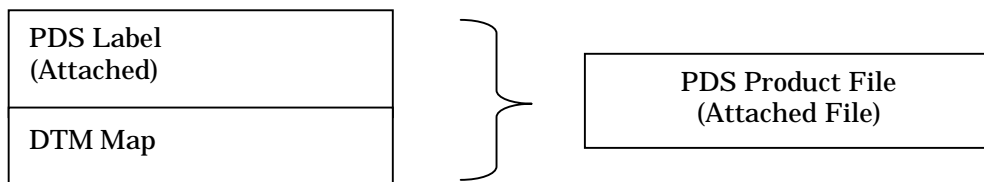

Fig. 2.2-2 Configuration of the PDS Product File of the DTM Map

Table 2.2-1 presents the file-naming rules for each of the above-mentioned files that are described in detail in the following paragraphs.

Table 2.2-1 File-Naming Rules for DTM Map File

(Exp. DTM_MAP_01_N90E180S90W180SC.dtm)

Code	Start Position	Length (Bytes)	Preset Values
1	1	3	Product ID "DTM" fixed
2	4	1	Underscore "_" fixed
3	5	3	Product type "MAP" fixed
4	8	1	Underscore "_" fixed
5	9	2	L2DB version nn: 2 digits
6	11	1	Underscore "_" fixed
7	12	3	Upper left latitude S90 to N90
8	15	4	Upper left longitude E000 to E360
9	19	3	Lower right latitude S90 to N90
10	22	4	Lower right longitude E000 to E360
11	26	2	Map projection "SC": Simple cylindrical "PS": Polar stereo
12	28	4	Extensions .dtm: DTM Map PDS product .jpg: Thumbnail .ctg: Catalog Information .sl2: DTM Map dataset .low: Low-Resolution Image
Total	-	31	

2.2.1 Catalog Information File

This attached Information File outlines the DTM Map and defines the items that can be used to retrieve products from the L2DB subsystem.

Tables 2.2-2 and 2.2-3 describe the items of the Catalog Info File. Each item is described with the following format within 1 line.

Format:

Keyword = String Value

Comments are composed of multiple comma-delimited items from Table 2.2-4 with the following format.

Format:

CommentInfo = Keyword1 = "String Value", Keyword2 = "String Value", ...

Unless otherwise specified, the basic principle is that the numeric value of each item should be zero suppressed; the string value of each item should contain no space character, and be left-aligned.

Table 2.2-2 Items of the Catalog Information File (DTM Map)

Item	Keyword	Format of Preset Value	Content of Preset Value
Data File Name	DataFileName	AAAA...AAAA (MAX 31 digits)	DTM MAP PDS product file name
Data File Size	DataFileSize	NNNNNNNNNNNN (MAX 12 digits)	DTM MAP PDS product file size <byte>
Data File Format	DataFileFormat	AAAA...AAAA (MAX 16 digits)	DTM MAP PDS product file format
Thumbnail File Name	ThumbnailFileName	AAAA...AAAA (MAX 65 digits)	Thumbnail file name
Thumbnail File Size	ThumbnailFileSize	NNNNNNNNNNNN (MAX 12 digits)	Thumbnail file size <byte>
Thumbnail File Format	ThumbnailFileFormat	AAAA (MAX 4 digits)	JPEG: fixed
Instrument Name	InstrumentName	AAAA...AAAA (MAX 16 digits)	LISM: fixed
Processing Level	ProcessingLevel	AAAA...AAAA (MAX 16 digits)	MAP: fixed
Product ID	ProductID	AAAA...AAAA (MAX 30 digits)	DTM_MAP, DTM_MAP_S
Product Version	ProductVersion	AAAA...AAAA (MAX 16 digits)	nn: L2DB version
Access Level	AccessLevel	N	0: Read Only 1: LISM core members only 2: LISM members only 3: SELENE members only 4: All members
Upper Left Latitude	UpperLeftLatitude	SNN.NNNNNN	<degree>

Upper Left Longitude	UpperLeftLongitude	NNN.NNNNNN	<degree>
Upper Right Latitude	UpperRightLatitude	SNN.NNNNNN	<degree>
Upper Right Longitude	UpperRightLongitude	NNN.NNNNNN	<degree>
Lower Left Latitude	LowerLeftLatitude	SNN.NNNNNN	<degree>
Lower Left Longitude	LowerLeftLongitude	NNN.NNNNNN	<degree>
Lower Right Latitude	LowerRightLatitude	SNN.NNNNNN	<degree>
Lower Right Longitude	LowerRightLongitude	NNN.NNNNNN	<degree>
Scene Center Latitude	SceneCenterLatitude	SNN.NNNNNN	<degree>
Scene Center Longitude	SceneCenterLongitude	NNN.NNNNNN	<degree>
Comment	CommentInfo	AAAA...AAAA (MAX 4000 digits)	(see Table 2.2-4)
Free Keywords	FreeKeyword	-	(see Table 2.2-3)

Table 2.2-3 Free Keywords in the Catalog Information File (DTM Map)

Item	Keyword	Format of Preset Value	Content of Preset Value
DTM Minimum Value	DTMMinimum	SNNNNN	<m>
DTM Maximum Value	DTMMaximum	SNNNNN	<m>
DTM Mean Value	DTMAverage	SNNNNN	<m>
DTM Standard Deviation	DTMStdev	NNNNN	<m>
DTM Mode Pixel Value	DTMModePixel	SNNNNN	<m>
Dummy Pixel Percentage	DTMQAPercentDummyPixel	NNN	<%>
Bad Pixel Percentage	DTMQAPercentBadPixel	NNN	<%>
Shadow Pixel Percentage	DTMQAPercentShadowPixel	NNN	<%>

Table 2.2-4 Comments in the Catalog Information File (DTM Map)

Item	Keyword	Format of Preset Value	Content of Preset Value
Creation Date	ProductCreationTime	yyyy-mm-ddThh:mm:ssZ	

2.2.2 Thumbnail

Thumbnail files are JPEG-compressed images of the image data included in the DTM Map. Refer to ISO/IEC 10918-1 for the JPEG format. Table 2.2-5 provides the specifications for the thumbnails.

Table 2.2-5 Specifications for the Thumbnail Files

Number of Pixels	Number of Lines	File Size	Format
512 or less	512 or less	100kb or less	JPEG

2.2.3 PDS Product

The DTM Map PDS Product is an attached PDS Product composed of the PDS Label and the Image Data Object. The PDS Label contains text data, and the Image Data Object contains binary data.

The configuration and structure of the DTM Map PDS Product File are presented in Figs. 2.2-3 and 2.2-4.

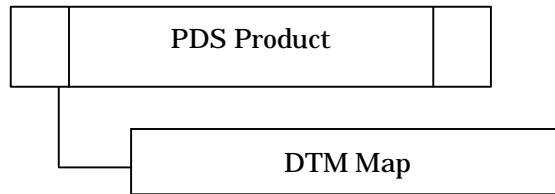

Fig. 2.2-3 Configuration of the DTM Map PDS Product File

PDS Label	PDS Label Common Items	
	Object Position Specification	
	Product Information	File Attributes
		Product Attributes
		Scene Attributes
		Image Map Projection
		Processing Parameter Description
		Image Information
Quality Information		
Image Data Object	DTM Map	

Fig. 2.2-4 Structure of the DTM Map PDS Product File

(1) PDS Label (For DTM Map)

This PDS Label is attached to the DTM Map Product. It is detailed in Table 2.2-6.

Table 2.2-6 Items of PDS Label (For DTM Map)

Category	Item	Description form	Explanation	Value
PDS label common items				
	PDS version ID	PDS_VERSION_ID = "%s"	PDS version ID	"PDS3" fixed
	File record type	RECORD_TYPE = "%s"	File record type	"UNDEFINED" fixed
	File name	FILE_NAME = "%s"	File name of this product (product ID + extension)	
	Product ID	PRODUCT_ID = "%s"	Unique ID given to every product	
	Data file format ID	DATA_FORMAT = "%s"	Data file format ID	"PDS" fixed
Object position specification				
	Head position of image object	^IMAGE = %10d <BYTES>	Head position of the image object	
Product information				
File attributes	Software name	SOFTWARE_NAME = "%s"	Software name that created the DTM PDS product	TBD
	Software version	SOFTWARE_VERSION = "%s"	Software version that created the DTM PDS product	"n.n.n" (TBD)
	Processing level	PROCESS_VERSION_ID = "%s"	Processing level ID	"L3D": DTM/TC ortho, DTM mosaic and TC ortho mosaic "MAP": DTM map and TC ortho map
	Product creation time	PRODUCT_CREATION_TIME = %s	Product creation time	YYYY-MM-DDTHH:MM:SSZ
Product attributes	Producer ID	PRODUCER_ID = "%s"	Data producer ID	"LISM" fixed
	Product set ID	PRODUCT_SET_ID = "%s"	Product set ID	"DTM_TCOrtho": DTM/TC ortho "DTM_MAP": DTM map "TCOrtho_MAP": TC ortho map "DTM_TCOrtho_S": DTM/TC ortho (special product) "DTM_MAP_S": DTM map (special product) "TCOrtho_MAP_S": TC ortho map (special product) "DTM_MSC": DTM mosaic (special product) "TCOrtho_MSC": TC ortho mosaic (special product)
	Product version ID	PRODUCT_VERSION_ID = "%s"	Product version ID	"01" to "99"
Scene attributes	Mission name	MISSION_NAME = "%s"	Mission name	"SELENE" fixed
	Spacecraft name	SPACECRAFT_NAME = "%s"	Spacecraft name	"SELENE-M" fixed
	Data set ID	DATA_SET_ID = "%s"	This data set ID	TBD
	Instrument name	INSTRUMENT_NAME = "%s"	Full name of the instrument	"Terrain_Camera"
	Instrument ID	INSTRUMENT_ID = "%s"	Instrument ID	"TC"
	Upper left latitude	UPPER_LEFT_LATITUDE = %10.6f <deg>	Latitude at the center of the upper-left corner pixel of the image that contains dummy pixels	-90 to 90
	Upper left longitude	UPPER_LEFT_LONGITUDE = %10.6f <deg>	Longitude at the center of the upper-left corner pixel of the image that contains dummy pixels	0 to 360
	Upper right latitude	UPPER_RIGHT_LATITUDE = %10.6f <deg>	Latitude at the center of the upper-right corner pixel of the image that contains dummy pixels	-90 to 90
	Upper right longitude	UPPER_RIGHT_LONGITUDE = %10.6f <deg>	Longitude at the center of the upper-right corner pixel of the image that contains dummy pixels	0 to 360
	Lower left latitude	LOWER_LEFT_LATITUDE = %10.6f <deg>	Latitude at the center of the lower-left corner pixel of the image that contains dummy pixels	-90 to 90
	Lower left longitude	LOWER_LEFT_LONGITUDE = %10.6f <deg>	Longitude at the center of the lower-left corner pixel of the image that contains dummy pixels	0 to 360
	Lower right latitude	LOWER_RIGHT_LATITUDE = %10.6f <deg>	Latitude at the center of the lower-right corner pixel of the image that contains dummy pixels	-90 to 90
	Lower right longitude	LOWER_RIGHT_LONGITUDE = %10.6f <deg>	Longitude at the center of the lower-right corner pixel of the image that contains dummy pixels	0 to 360
	Image center latitude	IMAGE_CENTER_LATITUDE = %10.6f <deg>	Latitude at the center pixel of the image	-90 to 90
Image center longitude	IMAGE_CENTER_LONGITUDE = %10.6f <deg>	Longitude at the center pixel of the image	0 to 360	
Map projection information				
Map projection	OBJECT = IMAGE_MAP_PROJECTION MAP_PROJECTION_TYPE = "%s"	Name of the map projection	"Simple Cylindrical", "Stereographic", "Lambert Conformal" or "Transverse Mercator"	
Coordinate system type	COORDINATE_SYSTEM_TYPE = "%s"	Type of the coordinate system	"BODY_FIXED_ROTATING" fixed	
Coordinate system name	COORDINATE_SYSTEM_NAME = "%s"	Full name of the coordinate system	"PLANETOCENTRIC" fixed	
A axis radius	A_AXIS_RADIUS = %8.3f <km>	A axis radius of the Moon	1737.4 <KM> default	
B axis radius	B_AXIS_RADIUS = %8.3f <km>	B axis radius of the Moon	1737.4 <KM> default	
C axis radius	C_AXIS_RADIUS = %8.3f <km>	C axis radius of the Moon	1737.4 <KM> default	
First standard parallel	FIRST_STANDARD_PARALLEL = %10.6f <deg>	First standard parallel Used for "Lambert Conformal" projection.	-90 to 90 for "Lambert Conformal" projection "N/A" for other map projection	
Second standard parallel	SECOND_STANDARD_PARALLEL = %10.6f <deg>	Second standard parallel Used for "Lambert Conformal" projection.	-90 to 90 for "Lambert Conformal" projection "N/A" for other map projection	
Positive longitude direction	POSITIVE_LONGITUDE_DIRECTION = "%s"	Positive direction of longitude	"EAST" fixed	
Center latitude	CENTER_LATITUDE = %10.6f <deg>	Latitude at the origin in a given MAP_PROJECTION_TYPE	-90 to 90	
Center longitude	CENTER_LONGITUDE = %10.6f <deg>	Longitude at the origin in a given MAP_PROJECTION_TYPE	0 to 360	
Reference latitude	REFERENCE_LATITUDE = %10.6f <deg>	Zero latitude in a rotated spherical coordinate system that was used in a given MAP_PROJECTION_TYPE	"N/A" fixed	
Reference longitude	REFERENCE_LONGITUDE = %10.6f <deg>	Zero longitude in a rotated spherical coordinate system that was used in a given MAP_PROJECTION_TYPE	"N/A" fixed	
First line number	LINE_FIRST_PIXEL = %d	Line number of the upper end pixel of the image	1 fixed	
Last line number	LINE_LAST_PIXEL = %d	Line number of the lower end pixel of the image		
First sample number	SAMPLE_FIRST_PIXEL = %d	Sample number of the left end pixel of the image	1 fixed	
Last sample number	SAMPLE_LAST_PIXEL = %d	Sample number of the right end pixel of the image		
Map orientation angle	MAP_PROJECTION_ROTATION = %f <deg>	Clockwise rotation of the line and sample coordinates with respect to the map projection origin	0.0 fixed	
Map resolution	MAP_RESOLUTION = %f <pixel/deg>	Total number of pixels in a box area of 1-degree latitude x 1-degree longitude for Simple Cylindrical Projection	"N/A" is given when MAP_PROJECTION_TYPE is not "Simple Cylindrical".	
Map scale	MAP_SCALE = %f <km/pixel>	Actual distance, in km, between two points at the origin in a given MAP_PROJECTION_TYPE		
Maximum latitude	MAXIMUM_LATITUDE = %10.6f <deg>	Latitude at the center of the northernmost pixel in 4 corner pixels	-90 to 90	
Minimum latitude	MINIMUM_LATITUDE = %10.6f <deg>	Latitude at the center of the southernmost pixel in 4 corner pixels	-90 to 90	
Easternmost longitude	EASTERMOST_LONGITUDE = %10.6f <deg>	Longitude at the center of the easternmost	0 to 360	

	Westernmost longitude	WESTERNMOST_LONGITUDE = %10.6f <deg>	pixel in 4 corner pixels Longitude at the center of the westernmost pixel in 4 corner pixels	0 to 360
	Line projection offset	LINE_PROJECTION_OFFSET = %f	Map projection coordinates, in pixels, at the center of the upper-left corner pixel of this image	
	Sample projection offset	SAMPLE_PROJECTION_OFFSET = %f	Map projection coordinates, in pixels, at the center of the upper-left corner pixel of this image	
	Resampling method	RESAMPLING_METHOD = "%s"	Name of image resampling method	"Nearest Neighbor", "Bi-linear", "Cubic Convolution" or "Logical Sum"
		END_OBJECT = IMAGE_MAP_PROJECTION		
Processing parameter description		OBJECT = PROCESSING_PARAMETERS		
	Parameter set name	PARAMETER_SET_NAME = "%s"	Name of the processing parameter set	TBD
	Geometric correction method in the horizontal direction	HORIZONTAL_TRANSFORM_METHOD = "%s"	Method of geometric correction in the horizontal direction	"NON": no correction "PARALLEL": parallel shift "AFFINE": affine transformation "HELMERT": helmert transformation "PSEUDO-AFFINE": pseudo-affine transformation
	Geometric correction method in the vertical direction	VERTICAL_TRANSFORM_METHOD = "%s"	Method of geometric correction in the vertical direction	"NON": no correction "OFFSET": offset correction "TREND": trend correction
	Mosaic priority	MOSAIC_PRIORITY = ("%s", %f)	Values to decide the order of mosaicking	1st value "NON": file designation order "CENTER": from center to outside "E-W": from east to west "W-E": from west to east "N-S": from north to south "S-N": from south to north "DATE_NEW": new observation date order "DTM_QUALITY": DTM good quality order "SUN_ELEVATION": small order of the difference between the sun elevation and the 2nd value "SUN_AZIMUTH": small order of the difference between the sun azimuth and the 2nd value "SUN_PHASE_ANGLE": small order of the difference between the sun phase angle and the 2nd value 2nd value Value of the sun elevation, azimuth, or phase angle "N/A" is given to the 2nd value when the 1st value is not "SUN_ELEVATION", "SUN_AZIMUTH" or "SUN_PHASE_ANGLE".
	Smoothing width	SMOOTHING_WIDTH = %d	Smoothing width, in pixels, for the boundary between images of the mosaicking	
		END_OBJECT = PROCESSING_PARAMETERS		
Image information		OBJECT = IMAGE		
	Bands	BANDS = %d	Total number of bands in this image	1 fixed
	Band storage type	BAND_STORAGE_TYPE = "%s"	Storage sequence of lines, samples, and bands in this image	"BAND_SEQUENTIAL" fixed
	Band name	BAND_NAME = "%s"	Spectral range(s) associated with each band in single-band or multi-band data	"N/A" fixed
	Lines	LINES = %d	Total number of lines in this image	
	Line samples	LINE_SAMPLES = %d	Total number of pixels in a line	
	Sample type	SAMPLE_TYPE = "%s"	Image data type	"MSB_INTEGER" (DTM) or "MSB_UNSIGNED_INTEGER" (TC ortho)
	Sample bits	SAMPLE_BITS = %d	Total number of bits used to store one data sample value	8 or 16
	Meaning of pixel value	IMAGE_VALUE_TYPE = "%s"	Meaning of the value of the pixel	"DN", "RADIANCE", "REFLECTANCE" or "ELEVATION"
	Sample bit mask	SAMPLE_BIT_MASK = %s	Active bits in a sample	2#1111111#; 8 bits 2#1111111111111111#; 16 bits
	Offset	OFFSET = %f	Offset value used in the DN for physical quantity conversion DTM and DTM map: Elevation = DN*SCALING_FACTOR+OFFSET Unit is "meter" from the Moon radius. TC ortho and TC ortho map (REF_CNV_SW=OFF): Radiance = DN*SCALING_FACTOR+OFFSET Unit is "w/m2/μ m'sr" TC ortho map (REF_CNV_SW=ON): Reflectivity = DN*SCALING_FACTOR+OFFSET Unit is "%"	
	Scaling factor	SCALING_FACTOR = %f	Gain used in the DN for physical quantity conversion	
	Stretched flag	STRETCHED_FLAG = "%s"	Whether a data object has been stretched to make it easy to see	"FALSE" fixed
	Valid minimum	VALID_MINIMUM = %d	Minimum value that is valid for a data object	-9989: DTM 2: TC ortho
	Valid maximum	VALID_MAXIMUM = %d	Maximum value that is valid for a data object	32766 fixed
	Dummy	DUMMY = %d	Value that indicates the dummy (blank) pixel of the image	-9999: DTM 0: TC ortho
	Minimum	MINIMUM = %d	Minimum value in this image except the invalid pixels	When the total number of valid pixels is 0, the value of DTM sets -9999 and the value of the TC ortho sets -1.
	Maximum	MAXIMUM = %d	Maximum value in this image except the invalid pixels	When the total number of valid pixels is 0, the value of DTM sets -9999 and the value of the TC ortho sets -1.
	Average	AVERAGE = %f	Average value in this image except the invalid pixels	When the total number of valid pixels is 0, the value of DTM is set to -9999 and the value of the TC ortho is set to -1.
	Standard deviation	STDEV = %f	Standard deviation in this image except the invalid pixels	When the total number of valid pixels is 0, the value of DTM is set to -9999 and the value of the TC ortho is set to -1.
	Mode pixel	MODE_PIXEL = %d	Mode in this image except the invalid pixels	When the total number of valid pixels is 0, the value of DTM is set to -9999 and the value of the TC ortho is set to -1.
		END_OBJECT = IMAGE		
Quality information		OBJECT = QUALITY_INFO		

	Good pixel percentage	QA_PERCENT_GOOD_PIXEL = %f	Percentage of good pixels in all the DTM pixels	total number of QA_PERCENT_GOOD_PIXEL, QA_PERCENT_DUMMY_PIXEL and QA_PERCENT_BAD_PIXEL is 100.0
	Dummy pixel percentage	QA_PERCENT_DUMMY_PIXEL = %f	Percentage of dummy pixels in all the DTM pixels	
	Bad pixel percentage	QA_PERCENT_BAD_PIXEL = %f	Percentage of bad pixels in all the DTM pixels	
	Interpolated pixel percentage	QA_PERCENT_INTERPOLATED_PIXEL = %f	Percentage of interpolated pixels in all the DTM pixels	
	Shadow pixel percentage	QA_PERCENT_SHADOW_PIXEL = %f	Percentage of shadowed pixels in all the DTM pixels	
	Correlation threshold of bad pixel	BAD_PIXEL_THRESHOLD_CORRELATION = %f	Threshold of image correlation between stereo images to extract the bad pixel from the DTM	
	Slope threshold of bad pixel	BAD_PIXEL_THRESHOLD_SLOPE = %f <deg>	Slope angle threshold to extract the bad pixel from the DTM	
		END_OBJECT = QUALITY_INFO		
		END		

(2) Image Data Object

Format of the Image Data Object of the DTM Map PDS Product File is given in Table 2.2-7.

Table 2.2-7 Specifications for the Image Data Object

Image File	Bit Length	Format	Endian	Value
DTM Map	16	signed short integer	big endian	

2.2.4 Low-Resolution File

The Low-Resolution File is a resampled image data object of each LISM Map Product. The Low-Resolution File for the DTM Map is resampled at 1/32 pixel (128 pixel/degree) from the original image (Fig. 2.2-5). The image is in a raw format. The extension of this image file is assigned “.low” to distinguish it from the Map product file.

This file is used for the internal process of the L2DB system. If you request a DTM Map product for the L2DB system, this file is not included in the L2DB product.

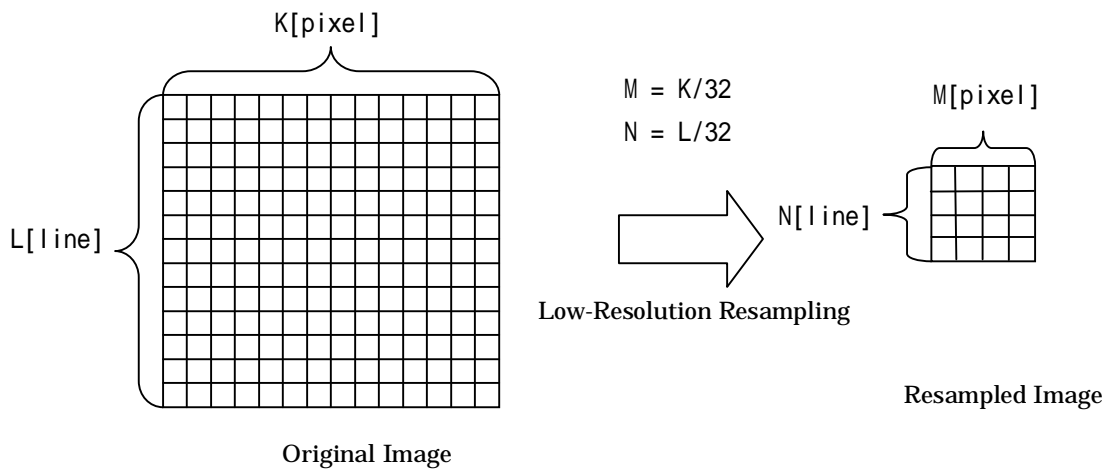

Fig. 2.2-5 Outline of Low-Resolution File Generation

2.3 TC Ortho Map

The TC Ortho Map is a dataset of the mosaicked scene TC Ortho data. It is a Tar archive composed of the following four files.

- Catalog Information File
- PDS Product File
- Low-Resolution File
- Thumbnail File

Figure 2.3-1 depicts the configuration of the TC Ortho Map File, and Fig. 2.3-2 presents the configuration of the TC Ortho Map PDS Product File.

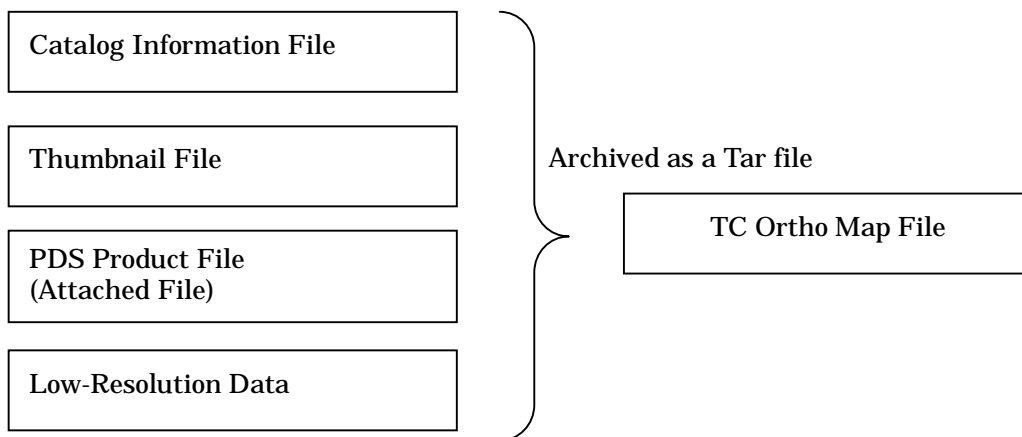

Fig. 2.3-1 Configuration of the TC Ortho Map File

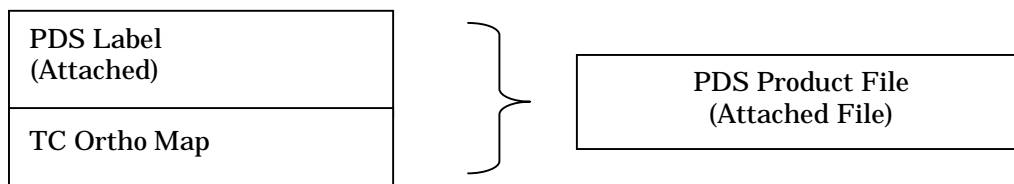

Fig. 2.3-2 Configuration of the PDS Product File of the TC Ortho Map

Table 2.3-1 presents the file-naming rules for each of the above-mentioned files, which are described in detail in the following paragraphs.

Table 2.3-1 File-Naming Rules for TC Ortho Map File

(Exp. TCO_MAP_01_N45E150N30E270SC.img)

Code	Start Position	Length (Byte)	Preset Values
1	1	3	Product ID "TCO" fixed
2	4	1	Underscore "_" fixed
3	5	3	Product type "MAP" fixed
4	8	1	Underscore "_" fixed
5	9	2	L2DB version nn: 2 digits
6	11	1	Underscore "_" fixed
7	12	3	Upper left latitude S90 to N90
8	15	4	Upper left longitude E000 to E360
9	19	3	Lower right latitude S90 to E90
10	22	4	Lower right longitude E000 to E360
11	26	2	Map projection "SC": Simple cylindrical "PS": polar stereo
12	28	4	Extensions .img: TC Ortho Map PDS product .jpg: Thumbnail .ctg: Catalog Information .sl2: TC Ortho Map dataset .low: Low-Resolution Image
Total	-	31	

2.3.1 Catalog Information File

The Catalog Information File is an attached Information File outlining the TC Ortho Map and defining the items that can be used to retrieve products from the L2DB subsystem.

Tables 2.3-2 and 2.3-3 describe the items of the Catalog Info File. Each item is described with the following format within one line.

Format:

Keyword = String Value

Comments are composed of multiple comma-delimited items from Table 2.3-4 with the following format.

Format:

CommentInfo = Keyword1 = "String Value", Keyword2 = "String Value", ...

Unless otherwise specified, the basic principle is that the numeric value of each item should be zero suppressed; the string value of each item should contain no space character, and be left-aligned.

Table 2.3-2 Items of the Catalog Information File (TC Ortho Map)

Item	Keyword	Format of Preset Value	Content of Preset Value
Data File Name	DataFileName	AAAA...AAAA (Max 31 digits)	TCOrtho MAP PDS Product Name
Data File Size	DataFileSize	NNNNNNNNNNNN (Max 12 digits)	TCOrtho MAP PDS Product Size <byte>
Data File Format	DataFileFormat	AAAA...AAAA (Max 16 digits)	TCOrtho MAP PDS Product Format
Thumbnail File Name	ThumbnailFileName	AAAA...AAAA (Max 65 digits)	Thumbnail file name
Thumbnail File Size	ThumbnailFileSize	NNNNNNNNNNNN (Max 12 digits)	Thumbnail file size <byte>
Thumbnail File Format	ThumbnailFileFormat	AAAA (Max 4 digits)	JPEG: fixed
Instrument Name	InstrumentName	AAAA...AAAA (Max 16 digits)	LISM: fixed
Processing Level	ProcessingLevel	AAAA...AAAA (Max 16 digits)	MAP: fixed
Product ID	ProductID	AAAA...AAAA (Max 30 digits)	TCOrtho_MAP, TCOrtho_MAP_S
Product Version	ProductVersion	AAAA...AAAA (Max 16 digits)	nn: L2DB version
Access Level	AccessLevel	N	0: Read Only 1: LISM core members only 2: LISM members only 3: SELENE members only 4: All members
Upper Left Latitude	UpperLeftLatitude	SNN.NNNNNN	<degree>

Upper Left Longitude	UpperLeftLongitude	NNN.NNNNNN	<degree>
Upper Right Latitude	UpperRightLatitude	SNN.NNNNNN	<degree>
Upper Right Longitude	UpperRightLongitude	NNN.NNNNNN	<degree>
Lower Left Latitude	LowerLeftLatitude	SNN.NNNNNN	<degree>
Lower Left Longitude	LowerLeftLongitude	NNN.NNNNNN	<degree>
Lower Right Latitude	LowerRightLatitude	SNN.NNNNNN	<degree>
Lower Right Longitude	LowerRightLongitude	NNN.NNNNNN	<degree>
Scene Center Latitude	SceneCenterLatitude	SNN.NNNNNN	<degree>
Scene Center Longitude	SceneCenterLongitude	NNN.NNNNNN	<degree>
Comment	CommentInfo	AAAA...AAAA (Max 4000 digits)	(see Table 2.3-4)
Free Keywords	FreeKeyword	-	(see Table 2.3-3)

Table 2.3-3 Free Keywords in the Catalog Information File (TC Ortho Map)

Item	Keyword	Format of Preset Value	Content of Preset Value
TCO Max Value	TCOMaximum	NNNN	
TCO Mean Value	TCOAverage	NNNN	
TCO Standard Deviation	TCOStdev	NNNN	
TCO Mode Pixel Value	TCOModePixel	NNNN	

Table 2.3-4 Comments in the Catalog Information File (TC Ortho Map)

Item	Keyword	Format of Preset Value	Content of Preset Value
Creation Date	ProductCreationTime	<i>yyyy-mm-ddThh:mm:ssZ</i>	

2.3.2 Thumbnail

Thumbnail files are JPEG-compressed images of the image data that the TC Ortho Map includes. Refer to ISO/IEC 10918-1 for the JPEG format. Table 2.3-5 provides the specifications for the thumbnails.

Table 2.3-5 Specifications for the Thumbnail Files

Number of Pixels	Number of Lines	File Size	Format
512 or less	512 or less	100Kb or less	JPEG

2.3.3 PDS Product

TC Ortho Map PDS Product is an attached PDS Product composed of the PDS Label and the Image Data Object. The PDS Label contains text data, and the Image Data Object contains binary data.

The configuration and structure of the TC Ortho Map PDS Product File are presented in Figs. 2.3-3 and 2.3-4.

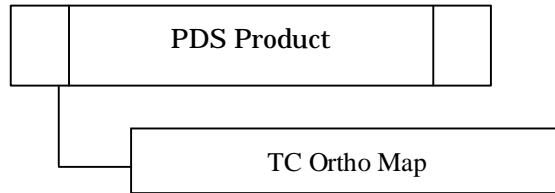

Fig. 2.3-3 Configuration of the TC Ortho Map PDS Product File

PDS Label	PDS Label Common Items	
	Object Position Specification	
	Product Information	File Attributes
		Product Attributes
		Scene Attributes
		Image Map Projection
		Processing Parameter Description
Image Information		
Image Data Object	TC Ortho Map	

Fig. 2.3-4 Structure of a TC Ortho Map PDS Product File

(1) PDS Label (For TC Ortho Map)

This PDS Label is attached to the TC Ortho Map PDS Product. It is detailed in Table 2.3-6.

Table 2.3-6 Items of PDS Label (For TC Ortho Map)

Category	Item	Description form	Explanation	Value
PDS label common items				
	PDS version ID	PDS_VERSION_ID = "%s"	PDS version ID	"PDS3" fixed
	File record type	RECORD_TYPE = "%s"	File record type	"UNDEFINED" fixed
	File name	FILE_NAME = "%s"	File name of this product (product ID + extension)	
	Product ID	PRODUCT_ID = "%s"	Unique ID given to every product	
	Data file format ID	DATA_FORMAT = "%s"	Data file format ID	"PDS" fixed
Object position specification				
	Head position of image object	*IMAGE = \$!0G <BYTES>	Head position of the image object	
Product information				
File attributes	Software name	SOFTWARE_NAME = "%s"	Software name that created the DTM PDS product	TBD
	Software version	SOFTWARE_VERSION = "%s"	Software version that created the DTM PDS product	"n.n.n" (TBD)
	Processing level	PROCESS_VERSION_ID = "%s"	Processing level ID	"L3D": DTM/TC ortho, DTM mosaic and TC ortho mosaic "MAP": DTM map and TC ortho map
	Product creation time	PRODUCT_CREATION_TIME = %s	Product creation time	YYYY-MM-DDTHH:MM:SSZ
Product attributes	Producer ID	PRODUCER_ID = "%s"	Data producer ID	"LISM" fixed
	Product set ID	PRODUCT_SET_ID = "%s"	Product set ID	"DTM_TCOrtho": DTM/TC ortho "DTM_MAP": DTM map "TCOrtho_MAP": TC ortho map "DTM_TCOrtho_S": DTM/TC ortho (special product) "DTM_MAP_S": DTM map (special product) "TCOrtho_MAP_S": TC ortho map (special product) "DTM_MSC": DTM mosaic (special product) "TCOrtho_MSC": TC ortho mosaic (special product)
	Product version ID	PRODUCT_VERSION_ID = "%s"	Product version ID	"01" to "99"
Scene attributes	Mission name	MISSION_NAME = "%s"	Mission name	"SELENE" fixed
	Spacecraft name	SPACECRAFT_NAME = "%s"	Spacecraft name	"SELENE-M" fixed
	Data set ID	DATA_SET_ID = "%s"	This data set ID	TBD
	Instrument name	INSTRUMENT_NAME = "%s"	Full name of the instrument	"Terrain_Camera"
	Instrument ID	INSTRUMENT_ID = "%s"	Instrument ID	"TC"
	Upper left latitude	UPPER_LEFT_LATITUDE = \$!0.6f <deg>	Latitude at the center of the upper-left corner pixel of the image that contains dummy pixels	-90 to 90
	Upper left longitude	UPPER_LEFT_LONGITUDE = \$!0.6f <deg>	Longitude at the center of the upper-left corner pixel of the image that contains dummy pixels	0 to 360
	Upper right latitude	UPPER_RIGHT_LATITUDE = \$!0.6f <deg>	Latitude at the center of the upper-right corner pixel of the image that contains dummy pixels	-90 to 90
	Upper right longitude	UPPER_RIGHT_LONGITUDE = \$!0.6f <deg>	Longitude at the center of the upper-right corner pixel of the image that contains dummy pixels	0 to 360
	Lower left latitude	LOWER_LEFT_LATITUDE = \$!0.6f <deg>	Latitude at the center of the lower-left corner pixel of the image that contains dummy pixels	-90 to 90
	Lower left longitude	LOWER_LEFT_LONGITUDE = \$!0.6f <deg>	Longitude at the center of the lower-left corner pixel of the image that contains dummy pixels	0 to 360
	Lower right latitude	LOWER_RIGHT_LATITUDE = \$!0.6f <deg>	Latitude at the center of the lower-right corner pixel of the image that contains dummy pixels	-90 to 90
	Lower right longitude	LOWER_RIGHT_LONGITUDE = \$!0.6f <deg>	Longitude at the center of the lower-right corner pixel of the image that contains dummy pixels	0 to 360
	Image center latitude	IMAGE_CENTER_LATITUDE = \$!0.6f <deg>	Latitude at the center pixel of the image	-90 to 90
Image center longitude	IMAGE_CENTER_LONGITUDE = \$!0.6f <deg>	Longitude at the center pixel of the image	0 to 360	
Map projection information				
	Map projection	OBJECT = IMAGE_MAP_PROJECTION MAP_PROJECTION_TYPE = "%s"	Map projection	"Simple Cylindrical", "Stereographic", "Lambert Conformal" or "Transverse Mercator"
	Coordinate system type	COORDINATE_SYSTEM_TYPE = "%s"	Type of the coordinate system	"BODY_FIXED_ROTATING" fixed
	Coordinate system name	COORDINATE_SYSTEM_NAME = "%s"	Full name of the coordinate system	"PLANETOCENTRIC" fixed
	A axis radius	A_AXIS_RADIUS = \$8.3f <km>	A axis radius of the Moon	1737.4 <KM> default
	B axis radius	B_AXIS_RADIUS = \$8.3f <km>	B axis radius of the Moon	1737.4 <KM> default
	C axis radius	C_AXIS_RADIUS = \$8.3f <km>	C axis radius of the Moon	1737.4 <KM> default
	First standard parallel	FIRST_STANDARD_PARALLEL = \$!0.6f <deg>	First standard parallel Used for "Lambert Conformal" projection.	-90 to 90 for "Lambert Conformal" projection "N/A" for other map projections
	Second standard parallel	SECOND_STANDARD_PARALLEL = \$!0.6f <deg>	Second standard parallel Used for "Lambert Conformal" projection.	-90 to 90 for "Lambert Conformal" projection "N/A" for other map projections
	Positive longitude direction	POSITIVE_LONGITUDE_DIRECTION = "%s"	Positive direction of longitude	"EAST" fixed
	Center latitude	CENTER_LATITUDE = \$!0.6f <deg>	Latitude at the origin in a given MAP_PROJECTION_TYPE	-90 to 90
	Center longitude	CENTER_LONGITUDE = \$!0.6f <deg>	Longitude at the origin in a given MAP_PROJECTION_TYPE	0 to 360
	Reference latitude	REFERENCE_LATITUDE = \$!0.6f <deg>	Zero latitude in a rotated spherical coordinate system that was used in a given MAP_PROJECTION_TYPE	"N/A" fixed
	Reference longitude	REFERENCE_LONGITUDE = \$!0.6f <deg>	Zero longitude in a rotated spherical coordinate system that was used in a given MAP_PROJECTION_TYPE	"N/A" fixed
	First line number	LINE_FIRST_PIXEL = %d	Line number of the upper end pixel of the image	1 fixed
	Last line number	LINE_LAST_PIXEL = %d	Line number of the lower end pixel of the image	
	First sample number	SAMPLE_FIRST_PIXEL = %d	Sample number of the left end pixel of the image	1 fixed
	Last sample number	SAMPLE_LAST_PIXEL = %d	Sample number of the right end pixel of the image	
	Map orientation angle	MAP_PROJECTION_ROTATION = %f <deg>	Clockwise rotation of the line and sample coordinates with respect to the map projection origin	0.0 fixed
	Map resolution	MAP_RESOLUTION = %f <pixel/deg>	Total number of pixels in a box area of 1-degree latitude x 1-degree longitude for Simple Cylindrical Projection	"N/A" is given when MAP_PROJECTION_TYPE is not "Simple Cylindrical"
	Map scale	MAP_SCALE = %f <km/pixel>	Actual distance, in km, between two points at the origin in a given MAP_PROJECTION_TYPE	
	Maximum latitude	MAXIMUM_LATITUDE = \$!0.6f <deg>	Latitude at the center of the northernmost pixel in 4 corner pixels	-90 to 90
	Minimum latitude	MINIMUM_LATITUDE = \$!0.6f <deg>	Latitude at the center of the southernmost pixel in 4 corner pixels	-90 to 90
	Easternmost longitude	EASTERMOST_LONGITUDE = \$!0.6f <deg>	Longitude at the center of the easternmost pixel in 4 corner pixels	0 to 360

Westernmost longitude	WESTERNMOST_LONGITUDE = %10.6f <deg>	Longitude at the center of the westernmost pixel in 4 corner pixels	0 to 360
Line projection offset	LINE_PROJECTION_OFFSET = %f	Map projection coordinates, in pixels, at the center of the upper-left corner pixel of this image	
Sample projection offset	SAMPLE_PROJECTION_OFFSET = %f	Map projection coordinates, in pixels, at the center of the upper-left corner pixel of this image	
Resampling method	RESAMPLING_METHOD = "%s"	Image resampling method	"Nearest Neighbor", "Bi-linear", "Cubic Convolution" or "Logical Sum"
	END_OBJECT = IMAGE_MAP_PROJECTION		
Processing parameter description			
	OBJECT = PROCESSING_PARAMETERS		
Parameter set name	PARAMETER_SET_NAME = "%s"	Name of the processing parameter set	TBD
Radiance conversion switch	REF_CNV_SW = "%s"	Execution flag of the photometric correction and the reflectivity conversion	"OFF" or "ON"
Reflectance conversion coefficient	REF_CNV_COEF = %f	Reflectance conversion coefficient	"N/A" is given when REF_CNV_SW is "OFF".
Standardized geometry condition for photometric correction	STANDARD_GEOMETRY = (%f,%f,%f)	Incidence angle, emission angle, and phase angle	"N/A" is given when REF_CNV_SW is "OFF".
Photometric correction method	PHOTO_CORR_ID = "%s"	ID of the photometric correction method	"USGS" or "BROWN" "N/A" is given when REF_CNV_SW is "OFF".
Photometric correction coefficients	PHOTO_CORR_COEF = (%f,%f,%f,...)	Photometric correction coefficients	"N/A" is given when REF_CNV_SW is "OFF".
Geometric correction method in the horizontal direction	HORIZONTAL_TRANSFORM_METHOD = "%s"	Method of geometric correction in the horizontal direction	"NON": no correction "PARALLEL": parallel shift "AFFINE": affine transformation "HELMERT": helmert transformation "PSEUDO AFFINE": pseudo affine transformation
Geometric correction method in the vertical direction	VERTICAL_TRANSFORM_METHOD = "%s"	Method of geometric correction in the vertical direction	"NON": no correction "OFFSET": offset correction "TREND": trend correction
Mosaic priority	MOSAIC_PRIORITY = ("%s",%f)	Values to decide the order of mosaicking	1st value "NON": file designation order "CENTER": from center to outside "E-W": from east to west "W-E": from west to east "N-S": from north to south "S-N": from south to north "DATE_NEW": new observation date order "DTM_QUALITY": DTM good quality order "SUN_ELEVATION": small order of the difference between the sun elevation and the 2nd value "SUN_AZIMUTH": small order of the difference between the Sun azimuth and the 2nd value "SUN_PHASE_ANGLE": small order of the difference between the sun phase angle and the 2nd value 2nd value Value of the Sun elevation, azimuth, or phase angle "N/A" is given as the 2nd value when the 1st value is not "SUN_ELEVATION", "SUN_AZIMUTH" or "SUN_PHASE_ANGLE".
Smoothing width	SMOOTHING_WIDTH = %d	Smoothing width, in pixels, for the boundary between images of the mosaicking	
	END_OBJECT = PROCESSING_PARAMETERS		
Image information			
	OBJECT = IMAGE		
Bands	BANDS = %d	Total number of bands in this image	1 fixed
Band storage type	BAND_STORAGE_TYPE = "%s"	Storage sequence of lines, samples, and bands in this image	"BAND_SEQUENTIAL" fixed
Band name	BAND_NAME = "%s"	Spectral range(s) associated with each band in single-band or multi-band data	"N/A" fixed
Lines	LINES = %d	Total number of lines in this image	
Line samples	LINE_SAMPLES = %d	Total number of pixels in a line	
Sample type	SAMPLE_TYPE = "%s"	Image data type	"MSB_INTEGER" (DTM) or "MSB_UNSIGNED_INTEGER" (TC or I)
Sample bits	SAMPLE_BITS = %d	Total number of bits used to store one data sample value	8 or 16
Meaning of pixel value	IMAGE_VALUE_TYPE = "%s"	Meaning of the value of the pixel	"DN", "RADIANCE", "REFLECTANCE" or "ELEVATION"
Sample bit mask	SAMPLE_BIT_MASK = %s	Active bits in a sample	2#11111111; 8 bits 2#1111111111111111; 16 bits
Offset	OFFSET = %f	Offset value used in the DN for physical quantity conversion DTM and DTM map: Elevation = DN*SCALING_FACTOR-OFFSET Unit is "meter" from the Moon radius. TC or I and TC or I map (REF_CNV_SW="OFF"): Radiance = DN*SCALING_FACTOR-OFFSET Unit is "w/m ² /μ m/sr" TC or I map (REF_CNV_SW="ON"): Reflectivity = DN*SCALING_FACTOR-OFFSET Unit is "%"	
Scaling factor	SCALING_FACTOR = %f	Gain used in the DN for physical quantity conversion	
Stretched flag	STRETCHED_FLAG = "%s"	Whether a data object has been stretched to make it easy to see	"FALSE" fixed
Valid minimum	VALID_MINIMUM = %d	Minimum value that is valid for a data object	-9999: DTM 2: TC or I
Valid maximum	VALID_MAXIMUM = %d	Maximum value that is valid for a data object	32766 fixed
Dummy	DUMMY = %d	Value that indicates the dummy (blank) pixel of the image	-9999: DTM 0: TC or I
Low saturation (REPR)	LOW_REPR_SATURATION = %d	Value that indicates the minimum saturation pixel after radiometric correction	1 fixed
Low saturation (INSTR)	LOW_INSTR_SATURATION = %d	Value that indicates the minimum saturation pixel during instrument measurement	1 fixed
High saturation (REPR)	HIGH_REPR_SATURATION = %d	Value that indicates the maximum saturation pixel after radiometric correction	32767 fixed
High saturation (INSTR)	HIGH_INSTR_SATURATION = %d	Value that indicates the maximum saturation pixel during instrument measurement	32767 fixed
Minimum	MINIMUM = %d	Minimum value in this image except the	When the total number of valid

			invalid pixels	pixels is 0, the value of DIM is set to -9999 and the value of the TC ortho is set to -1.
	Maximum	MAXIMUM = %d	Maximum value in this image except the invalid pixels	When the total number of valid pixels is 0, the value of DIM is set to -9999 and the value of the TC ortho is set to -1.
	Average	AVERAGE = %f	Average value in this image except the invalid pixels	When the total number of valid pixels is 0, the value of DIM is set to -9999 and the value of the TC ortho is set to -1.
	Standard deviation	STDEV = %f	Standard deviation in this image except the invalid pixels	When the total number of valid pixels is 0, the value of DIM is set to -9999 and the value of the TC ortho is set to -1.
	Mode pixel	MODE_PIXEL = %d	Mode in this image except the invalid pixels	When the total number of valid pixels is 0, the value of DIM is set to -9999 and the value of the TC ortho is set to -1.
		END_OBJECT = IMAGE		
		END		

(2) Image Data Object

Format of the Image Data Object of the TC Ortho Map PDS Product File is given in Table 2.3-7.

Table 2.3-7 Specifications for the Image Data Object

Image File	Bit Length	Format	Endian	Value
TC Ortho Map	16	Unsigned short integer	Big endian	

2.3.4 Low-Resolution File

The Low-Resolution File is a resampled image-data object of each LISM Map Product. The Low-Resolution File for the TC Ortho Map is resampled at 1/32 pixel (128 pixel/degree) from the original image (Fig. 2.2-5). The image is in a raw format. The extension of this image file is assigned “.low” to distinguish it from the Map product file.

This file is used for internal processes of the L2DB system. If you request a TC Ortho Map product for the L2DB system, this file will not be included in the L2DB product.

**KAGUYA (SELENE)
Product Format Description**

- LISM (TC/MI/SP) /SPICE Kernel-

Appendix-3

SPICE Kernel Format Description

Version 1.0

November 1, 2009

Index

1. Introduction.....	1
1.1 Purpose	1
2. Data Set	1
2.1 Catalog Information File	4
2.2 PDS Label.....	5
2.3 SPICE Kernel	6
2.3.1 Reference Document	6

1. Introduction

1.1 Purpose

This document describes the formats of the SPICE Kernel. These files provided by Japan Aerospace Exploration Agency (JAXA).

2. Data Set

The SPICE Kernel Data Set refers to the SELENE information file converted into SPICE Kernel, PDS Label in detached format and catalog information which are tar-archived. Composition of the SPICE Kernel Data Set is shown in Figure 2-1.

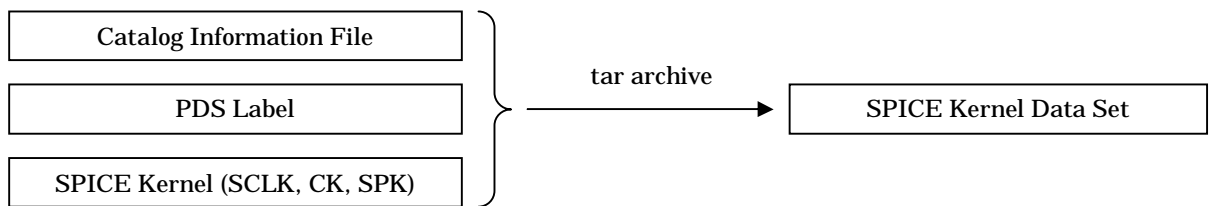

Figure 2-1 composition of the SPICE Kernel Data Set

The correspondence between the SELENE information file, the source, and the SPICE Kernel is shown in Table 2-1.

Table 2-1 Correspondence of the fount of SELENE information file and the SPICE Kernel

Generating element	generated SPICE Kernel
Spacecraft Clock Revision Data File	SCLK
Trajectory File	SPK
Attitude information File	CK

The nomenclatures used for each file the SPICE Kernel Data Set are described Table 2-2, Table 2-3 and Table 2-4.

Table 2-2 Rules used for File naming of SPICE Kernel Data Set (SCLK)

Code	Start position	Length (Byte)	Preset Value
1	1	2	Satellite identification SM : fixed (SELENE-M)
2	3	12	Date and Time of Start Data YYMMDDHHMMSS
3	15	1	Underscore _ : fixed
4	16	8	Day and Time of End Data DDHHMMSS
5	24	1	Underscore _ : fixed
6	25	3	Version number nnn
7	28	4	Extensions .tsc : SCLK .stg : Catalog Information File .lbl : PDS Label .sl2 : SPICE Kernel Data Set
Total	-	31	

Table 2-3 Rules used for File naming of SPICE Kernel Data Set (SPK)

Code	Start position	Length (Byte)	Preset Value
1	1	2	Satellite identification SM : fixed (SELENE-M)
2	3	1	Central astral body identification E : Center of the earth M : Center of the moon
3	4	10	Date and Time of Start Data YYMMDDHHMM
4	14	1	Underscore _ : fixed
5	15	8	Day and Time of End Data MMDDHHMM
6	23	1	Underscore _ : fixed
7	24	3	Version number nnn
8	27	4	Extensions .tsc : SPK .stg : Catalog Information File .lbl : PDS Label .sl2 : SPICE Kernel Data Set
Total	-	30	

Table 2-4 Rules used for File naming of SPICE Kernel Data Set (CK)

Code	Start position	Length (Byte)	Preset Value
1	1	2	Satellite identification SM : fixed (SELENE-M)
2	3	2	Station identification U1 : Usuda K1 : Kagoshima Gn : NGN ("n" is integer above 1.) Dn : DSN ("n" is integer above 1.)
3	5	1	Data class R : Real Data M : Repro Data
4	6	10	Date and Time of Start Data YYMMDDHHMM
5	16	1	Underscore _ : fixed
6	17	6	Day and Time of End Data DDHHMM
7	23	1	Underscore _ : fixed
8	24	3	Version number nnn
9	27	4	Extensions .tsc : CK .stg : Catalog Information File .lbl : PDS Label .sl2 : SPICE Kernel Data Set
Total	-	30	

2.1 Catalog Information File

The Catalog Information File Format for the SPICE Kernel Data Set is shown in Table 2-5.

Table 2-5 Catalog Information File of SPICE Kernel Data Set

Item	Keyword	Format of Preset Value	Content of Preset Value
Data File Name	DataFileName	AAAA...AAAA (31 digits)	SPICE Kernel file name
Data File Size	DataFileSize	NNNNNNNNNNNN (12 digits)	SPICE Kernel file size <byte>
Data File Format	DataFileFormat	AAAA...AAAA (16 digits)	SCLK : SCLK <fixed> CK : CK <fixed > SPK : SPK <fixed >
Instrument Name	InstrumentName	AAAA...AAAA (16 digits)	SPICE : fixed
Processing Level	ProcessingLevel	AAAA...AAAA (16 digits)	Normal < fixed >
Product ID	ProductID	AAAA...AAAA (30 digits)	dependent on the product
Product Version	ProductVersion	AAAA...AAAA (16 digits)	dependent on the product
Access Level	AccessLevel	N	N/A
Start Date Time	StartDateTime	<i>yyyy-mm-ddT hh:mm:ss.sssssZ</i>	Start Date and Time of the SPICE Kernel stored data
End Date Time	EndDateTime	<i>yyyy-mm-ddT hh:mm:ss.sssssZ</i>	End Date and Time of the SPICE Kernel stored data

2.2 PDS Label

The PDS Label of the SPICE Kernel Data Set is shown in Table 2-6.

Table 2-6 PDS Label of SPICE Kernel Data Set

		Keyword	Format of Preset Value	Content of Preset Value
PDS label common items		PDS version ID	PDS_VERSION_ID = "%s"	"PDS3" <fixed>
		File record type	RECORD_TYPE = "%s"	sclk : "STREAM" <default> ck : "UNDIEFIND" <default> spk : "UNDIEFIND" <default>
		File name	FILE_NAME = "%s"	SPICE Kernel file name sclk : *.tsc ck : *.bsp spk : *.bc
		Data file format ID	DATA_FORMAT = "%s"	"SPICE" <default>
Product information	File attributes	Software name	SOFTWARE_NAME = "%s"	Software name that created the SPICE PDS product
		Product ID	PRODUCT_ID = "%s"	SPICE Kernel file name The extension is removed from the file name.
			PROCESS_VERSION_ID = "%s"	"L2A" <fixed>
		Product creation time	PRODUCT_IDCREATION_TIME = "%s"	Data creation time "YYYY-MM-DDTHH:MM:SSZ"
	Product attributes	Producer ID	PRODUCER_ID = "%s"	"LISM" <fixed>
		Data type	PRODUCT_TYPE = "%s"	"N/A" <default>
		Product name	PRODUCT_SET_ID = "%s"	sclk : "SCLK" <default> ck : "SPK" <default> spk : "CK" <default>
		Product version	PRODUCT_VERSION_ID = "%s"	Version of L2DB accession
		Fount file name	SOURCE_FILE_NAME = "%s"	The fount data file name used for SPICE Kernel creation. sclk : Spacecraft Clock Revision Data File ck : Attitude information File spk : Trajectory File
		Mission name	MISSION_NAME = "%s"	"SELENE" <default>
		Spacecraft name	SPACECRAFT_NAEM = "%s"	"SELENE-M" <default>
		Data set ID	DATA_SET_ID = "%s"	This data set ID
		Instrument name	INSTRUMENT_NAME = "%s"	"N/A" <default>
		Mission phase name	MISSION_PHASE_NAME = "%s"	Mission phase name
		Target name	TARGET_NAME = "%s"	"MOON" <default>
		Spacecraft clock start count (TI)	SPACECRAFT_CLOCK_START_COUNT = %15.4F	Spacecraft clock start count (TI) spk : N/A
		Spacecraft clock stop count (TI)	SPACECRAFT_CLOCK_STOP_COUNT=%15.4F	Spacecraft clock stop count (TI) spk : N/A
		Spacecraft clock start time (UT)	START_TIME = "%s"	Spacecraft clock start time (UT) "YYYY-MM-DDTHH:MM:SS.sssZ"
		Spacecraft clock start time (UT)	STOP_TIME = "%s"	Spacecraft clock start time (UT) "YYYY-MM-DDTHH:MM:SS.sssZ"
Kernel Object Format Description Part			OBJECT = SPICE_KERNEL	
		Format	INTERCHANGE_FORMAT = %s	sclk : "ASCII" <default> ck,spk : "BINARY" <default>
		Kernel type	KERNEL_TYPE = %s	sclk : "CLOCK_COEFFICIENTS" <default> ck : "POINTING" <default> spk : "EPHEMERIS" <default>
		Kernel type abbreviation	KERNEL_TYPE_ID = %s	sclk : "SCLK" <default> ck : "SPK" <default> spk : "CK" <default>
		Comment	DESCRIPTION = %s	Comment
			END_OBJECT = SPICE_KERNEL	
			END	

2.3 SPICE Kernel

The item of SPICE Kernel of SELENE is shown in Table 2-7.

In addition, concerning the detail of SPICE Kernel, refer to the Required Reading of each Kernel of the following reference.

Table 2-7 Item of SPICE Kernel

Kernel	Stored Format	Content
SCLK	Text	Correspondence of Spacecraft clock and Ephemeris Time is stored.
SPK	Binary	The orbital information etc. of SELENE is stored.
CK	Binary	The attitude information of SELENE is stored.

2.3.1 Reference Document

- (1) SCLK Required Reading (06-Oct-1999,NAIF Document No.222.02)
- (2) SPK Required Reading (05-Sep-2002,NAIF Document No.168.10)
- (3) CK Required Reading (05-Sep-2002,NAIF Document No.174.08)